

## European Technical Approval ETA-06/0271

English translation prepared by DIBt - Original version in German language

Handelsbezeichnung  
*Trade name*

fischer Zykon-Einschlaganker FZEA II  
*fischer Zykon-Hammerset anchor FZEA II*

Zulassungsinhaber  
*Holder of approval*

fischerwerke GmbH & Co. KG  
Weinhalde 14-18  
72178 Waldachtal  
DEUTSCHLAND

Zulassungsgegenstand  
und Verwendungszweck

*Generic type and use  
of construction product*

Hinterschnittdübel in den Größen M8, M10 und M12 zur Verankerung  
im Beton  
*Undercut anchor of sizes M8, M10 and M12 for use in concrete*

Geltungsdauer:  
*Validity:*

vom  
*from*  
bis  
*to*

5 January 2007

5 January 2012

verlängert  
*extended*

vom  
*from*  
bis  
*to*

6 January 2012

6 January 2017

Herstellwerk  
*Manufacturing plant*

fischerwerke

Diese Zulassung umfasst  
*This Approval contains*

16 Seiten einschließlich 8 Anhänge  
*16 pages including 8 annexes*

## I LEGAL BASES AND GENERAL CONDITIONS

- 1 This European technical approval is issued by Deutsches Institut für Bautechnik in accordance with:
  - Council Directive 89/106/EEC of 21 December 1988 on the approximation of laws, regulations and administrative provisions of Member States relating to construction products<sup>1</sup>, modified by Council Directive 93/68/EEC<sup>2</sup> and Regulation (EC) N° 1882/2003 of the European Parliament and of the Council<sup>3</sup>;
  - *Gesetz über das In-Verkehr-Bringen von und den freien Warenverkehr mit Bauprodukten zur Umsetzung der Richtlinie 89/106/EWG des Rates vom 21. Dezember 1988 zur Angleichung der Rechts- und Verwaltungsvorschriften der Mitgliedstaaten über Bauprodukte und anderer Rechtsakte der Europäischen Gemeinschaften (Bauproduktengesetz - BauPG) vom 28. April 1998<sup>4</sup>, as amended by law of 31 October 2006<sup>5</sup>;*
  - Common Procedural Rules for Requesting, Preparing and the Granting of European technical approvals set out in the Annex to Commission Decision 94/23/EC<sup>6</sup>;
  - Guideline for European technical approval of "Metal anchors for use in concrete - Part 3: Undercut anchors", ETAG 001-03.
- 2 Deutsches Institut für Bautechnik is authorized to check whether the provisions of this European technical approval are met. Checking may take place in the manufacturing plant. Nevertheless, the responsibility for the conformity of the products to the European technical approval and for their fitness for the intended use remains with the holder of the European technical approval.
- 3 This European technical approval is not to be transferred to manufacturers or agents of manufacturers other than those indicated on page 1, or manufacturing plants other than those indicated on page 1 of this European technical approval.
- 4 This European technical approval may be withdrawn by Deutsches Institut für Bautechnik, in particular pursuant to information by the Commission according to Article 5(1) of Council Directive 89/106/EEC.
- 5 Reproduction of this European technical approval including transmission by electronic means shall be in full. However, partial reproduction can be made with the written consent of Deutsches Institut für Bautechnik. In this case partial reproduction has to be designated as such. Texts and drawings of advertising brochures shall not contradict or misuse the European technical approval.
- 6 The European technical approval is issued by the approval body in its official language. This version corresponds fully to the version circulated within EOTA. Translations into other languages have to be designated as such.

<sup>1</sup> Official Journal of the European Communities L 40, 11 February 1989, p. 12  
<sup>2</sup> Official Journal of the European Communities L 220, 30 August 1993, p. 1  
<sup>3</sup> Official Journal of the European Union L 284, 31 October 2003, p. 25  
<sup>4</sup> *Bundesgesetzblatt Teil I 1998*, p. 812  
<sup>5</sup> *Bundesgesetzblatt Teil I 2006*, p. 2407, 2416  
<sup>6</sup> Official Journal of the European Communities L 17, 20 January 1994, p. 34

## II SPECIFIC CONDITIONS OF THE EUROPEAN TECHNICAL APPROVAL

### 1 Definition of the product and intended use

#### 1.1 Definition of the construction product

The Fischer Zykon-Hammerset anchor FZEA II is an undercut anchor made of galvanised steel (designated as FZEA II) or stainless steel (designated as FZEA II A4) or high corrosion resistant steel (designated as FZEA II C) of sizes M8, M10 and M12 which is placed in an undercut hole and anchored by mechanical interlock with displacement-controlled installation.

An illustration of the product and intended use is given in Annex 1.

#### 1.2 Intended use

The anchor is intended to be used for anchorages for which requirements for mechanical resistance and stability and safety in use in the sense of the Essential Requirements 1 and 4 of Council Directive 89/106 EEC shall be fulfilled and failure of anchorages made with these products would cause risk to human life and/or lead to considerable economic consequences.

The anchor may be used for anchorages with requirements related to resistance to fire.

The anchor is to be used only for anchorages subject to static or quasi-static loading in reinforced or unreinforced normal weight concrete of strength classes C20/25 at minimum and C50/60 at most according to EN 206:2000-12.

The anchor may be used in cracked and non-cracked concrete.

##### Anchor made of galvanised steel (FZEA II):

The anchor made of galvanised steel may only be used in structures subject to dry internal conditions.

##### Anchor made of stainless steel (FZEA II A4):

The anchor made of stainless steel may be used in structures subject to dry internal conditions and also in structures subject to external atmospheric exposure (including industrial and marine environment), or exposure in permanently damp internal conditions, if no particular aggressive conditions exist. Such particular aggressive conditions are e.g. permanent, alternating immersion in seawater or the splash zone of seawater, chloride atmosphere of indoor swimming pools or atmosphere with extreme chemical pollution (e.g. in desulphurization plants or road tunnels where de-icing materials are used).

##### Anchor made of high corrosion resistant steel (FZEA II C):

The anchor made of high corrosion resistant steel may be used in structures subject to dry internal conditions and also in structures subject to external atmospheric exposure, in permanently damp internal conditions or in other particular aggressive conditions. Such particular aggressive conditions are e.g. permanent, alternating immersion in seawater or the splash zone of seawater, chloride atmosphere of indoor swimming pools or atmosphere with chemical pollution (e.g. in desulphurization plants or road tunnels where de-icing materials are used).

The provisions made in this European technical approval are based on an assumed working life of the anchor of 50 years. The indications given on the working life cannot be interpreted as a guarantee given by the producer, but are to be regarded only as a means for choosing the right products in relation to the expected economically reasonable working life of the works.

## 2 Characteristics of the product and methods of verification

### 2.1 Characteristics of the product

The anchor corresponds to the drawings and provisions given in Annexes 2 and 3. The characteristic material values, dimensions and tolerances of the anchor not given in Annexes 2 and 3 shall correspond to the respective values laid down in the technical documentation<sup>7</sup> of this European technical approval.

Regarding the requirements concerning safety in case of fire it is assumed that the anchor meets the requirements of class A1 in relation to reaction to fire in accordance with the stipulations of the Commission decision 96/603/EC, amended by 2000/605/EC.

The characteristic values for the design of anchorages are given in Annexes 4 and 5.

The characteristic values for the design of anchorages regarding resistance to fire are given in Annexes 6 and 7. They are valid for use in a system that is required to provide a specific fire resistance class.

Each anchor is marked with the identifying mark of the producer, the commercial name and the anchor size according to Annex 2. In addition, each anchor made of stainless steel is marked with the letters "A4" and each anchor made of high corrosion resistant steel is marked with the letter "C".

The anchor shall only be supplied as a complete unit.

### 2.2 Methods of verification

The assessment of fitness of the anchor for the intended use in relation to the requirements for mechanical resistance and stability and safety in use in the sense of the Essential Requirements 1 and 4 has been made in accordance with the "Guideline for European technical approval of Metal Anchors for Use in Concrete", Part 1 "Anchors in general" and Part 3 "Undercut anchors", on the basis of Option 1.

The assessment of the anchor for the intended use in relation to the requirements for resistance to fire has been made in accordance with the Technical Report TR 020 "Evaluation of anchorages in concrete concerning resistance to fire".

In addition to the specific clauses relating to dangerous substances contained in this European technical approval, there may be other requirements applicable to the products falling within its scope (e.g. transposed European legislation and national laws, regulations and administrative provisions). In order to meet the provisions of the Construction Products Directive, these requirements need also to be complied with, when and where they apply.

<sup>7</sup>

The technical documentation of this European technical approval is deposited at the Deutsches Institut für Bautechnik and, as far as relevant for the tasks of the approved bodies involved in the attestation of conformity procedure, is handed over to the approved bodies.

### 3 Evaluation and attestation of conformity and CE marking

#### 3.1 System of attestation of conformity

According to the decision 96/582/EG of the European Commission<sup>8</sup> the system 2(i) (referred to as system 1) of attestation of conformity applies.

This system of attestation of conformity is defined as follows:

System 1: Certification of the conformity of the product by an approved certification body on the basis of:

- (a) Tasks for the manufacturer:
  - (1) factory production control;
  - (2) further testing of samples taken at the factory by the manufacturer in accordance with a prescribed control plan;
- (b) Tasks for the approved body:
  - (3) initial type-testing of the product;
  - (4) initial inspection of factory and of factory production control;
  - (5) continuous surveillance, assessment and approval of factory production control.

Note: Approved bodies are also referred to as "notified bodies".

#### 3.2 Responsibilities

##### 3.2.1 Tasks for the manufacturer

###### 3.2.1.1 Factory production control

The manufacturer shall exercise permanent internal control of production. All the elements, requirements and provisions adopted by the manufacturer shall be documented in a systematic manner in the form of written policies and procedures, including records of results performed. This production control system shall insure that the product is in conformity with this European technical approval.

The manufacturer may only use initial/raw/constituent materials stated in the technical documentation of this European technical approval.

The factory production control shall be in accordance with the control plan which is part of the technical documentation of this European technical approval. The control plan is laid down in the context of the factory production control system operated by the manufacturer and deposited with Deutsches Institut für Bautechnik.<sup>9</sup>

The results of factory production control shall be recorded and evaluated in accordance with the provisions of the control plan.

###### 3.2.1.2 Other tasks for the manufacturer

The manufacturer shall, on the basis of a contract, involve a body which is approved for the tasks referred to in section 3.1 in the field of anchors in order to undertake the actions laid down in section 3.2.2 For this purpose, the control plan referred to in sections 3.2.1.1 and 3.2.2 shall be handed over by the manufacturer to the approved body involved.

The manufacturer shall make a declaration of conformity, stating that the construction product is in conformity with the provisions of this European technical approval.

<sup>8</sup> Official Journal of the European Communities L 254 of 08.10.1996.

<sup>9</sup> The control plan is a confidential part of the European technical approval and only handed over to the approved body involved in the procedure of attestation of conformity. See section 3.2.2.

### 3.2.2 Tasks for the approved bodies

The approved body shall perform the

- initial type-testing of the product,
  - initial inspection of factory and of factory production control,
  - continuous surveillance, assessment and approval of factory production control,
- in accordance with the provisions laid down in the control plan.

The approved body shall retain the essential points of its actions referred to above and state the results obtained and conclusions drawn in a written report.

The approved certification body involved by the manufacturer shall issue an EC certificate of conformity of the product stating the conformity with the provisions of this European technical approval.

In cases where the provisions of the European technical approval and its control plan are no longer fulfilled the certification body shall withdraw the certificate of conformity and inform Deutsches Institut für Bautechnik without delay.

### 3.3 CE marking

The CE marking shall be affixed on each packaging of the anchor. The letters "CE" shall be followed by the identification number of the approved certification body, where relevant, and be accompanied by the following additional information:

- the name and address of the holder of the approval (legal entity responsible for the manufacturer),
- the last two digits of the year in which the CE marking was affixed,
- the number of the EC certificate of conformity for the product,
- the number of the European technical approval,
- the number of the guideline for European technical approval,
- use category (ETAG 001-1 Option 1),
- size.

## 4 Assumptions under which the fitness of the product for the intended use was favourably assessed

### 4.1 Manufacturing

The European technical approval is issued for the product on the basis of agreed data/information, deposited with Deutsches Institut für Bautechnik, which identifies the product that has been assessed and judged. Changes to the product or production process, which could result in this deposited data/information being incorrect, should be notified to Deutsches Institut für Bautechnik before the changes are introduced. Deutsches Institut für Bautechnik will decide whether or not such changes affect the approval and consequently the validity of the CE marking on the basis of the approval and if so whether further assessment or alterations to the approval shall be necessary.

#### 4.2 Design of anchorages

The fitness of the anchor for the intended use is given under the following conditions:

The anchorages are designed in accordance with the "Guideline for European technical approval of Metal Anchors for Use in Concrete", Annex C, Method A, under the responsibility of an engineer experienced in anchorages and concrete work.

Verifiable calculation notes and drawings are taking account of the loads to be anchored.

The position of the anchor is indicated on the design drawings (e.g. position of the anchor relative to reinforcement or to supports).

The design of anchorages under fire exposure has to consider the conditions given in the Technical Report TR 020 "Evaluation of anchorages in concrete concerning resistance to fire". The relevant characteristic anchor values are given in Annexes 6 and 7. The design method covers anchors with a fire attack from one side only. If the fire attack is from more than one side, the design method may be taken only, if the edge distance of the anchor is  $c \geq 300$  mm.

#### 4.3 Installation of anchors

The fitness for use of the anchor can only be assumed if the anchor is installed as follows:

- Anchor installation carried out by appropriately qualified personnel and under the supervision of the person responsible for technical matters of the site,
- Use of the anchor only as supplied by the manufacturer without exchanging the components of an anchor,
- Anchor installation including drilling of the hole in accordance with the manufacturer's specifications and drawings and using the appropriate tools,
- Checks before placing the anchor to ensure that the strength class of the concrete in which the anchor is to be placed is in the range given and is not lower than that of the concrete to which the characteristic loads apply,
- Check of concrete being well compacted, e. g. without significant voids,
- Edge distances and spacings not less than the specified values without minus tolerances,.
- Positioning of the drill holes without damaging the reinforcement,
- Drilling the hole with the universal drill FZUB which is shown in Annex 3 until the collar of the drill reaches the concrete surface; making the undercut by circular swinging of the hammer drill with activated impact,
- In case of aborted hole: new drilling at a minimum distance away of twice the depth of the aborted hole or smaller distance if the aborted drill hole is filled with high strength mortar and if under shear or oblique tension load it is not in the direction of load application,
- Cleaning of the hole of drilling dust,
- Anchor installation such that the effective anchorage depth is complied with. This compliance is ensured when the anchor does no more exceed the concrete surface,
- Anchor expansion by impact on the cone using the setting tools given in Annex 3. The anchor is properly set if the stop of the pin reaches the expansion sleeve, and the impression of the setting tool is visible as illustrated in Annex 3;
- The fastening screw or threaded rod shall comply with the requirements given in Annex 2.
- The installation torque for fixing the attachment shall comply with the values given in Annex 3.

## 5 Indications to the manufacturer

The manufacturer is responsible to ensure that the information on the specific conditions according to 1 and 2 including Annexes referred to as well as sections 4.2 and 4.3 is given to those who are concerned. This information may be made by reproduction of the respective parts of the European technical approval. In addition all installation data shall be shown clearly on the package and/or on an enclosed instruction sheet, preferably using illustration(s).

The minimum data required are:

- Special universal drill bit FZUB,
- Thread diameter,
- Minimum/Maximum screw-in depth of the fastening screw or threaded rod,
- Minimum effective anchorage depth,
- Minimum hole depth,
- Maximum installation torque,
- Information on the installation procedure, including cleaning of the hole, preferably by means of an illustration,
- Reference to any special installation equipment needed,
- Identification of the manufacturing batch.

All data shall be presented in a clear and explicit form.

Georg Feistel  
Head of Department

*beglaubigt:*  
Scheller



English translation prepared by DIBt

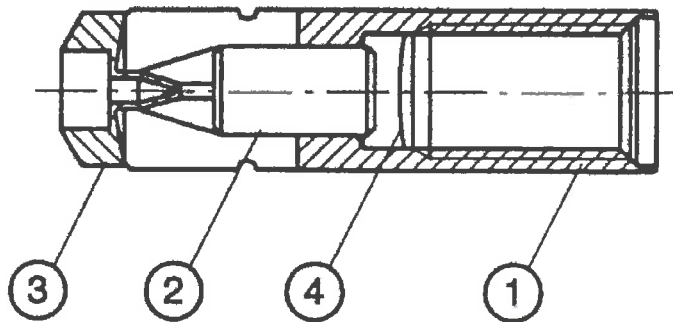

- ① Expansion sleeve
- ② Expansion pin
- ③ Distance part
- ④ Safety disk

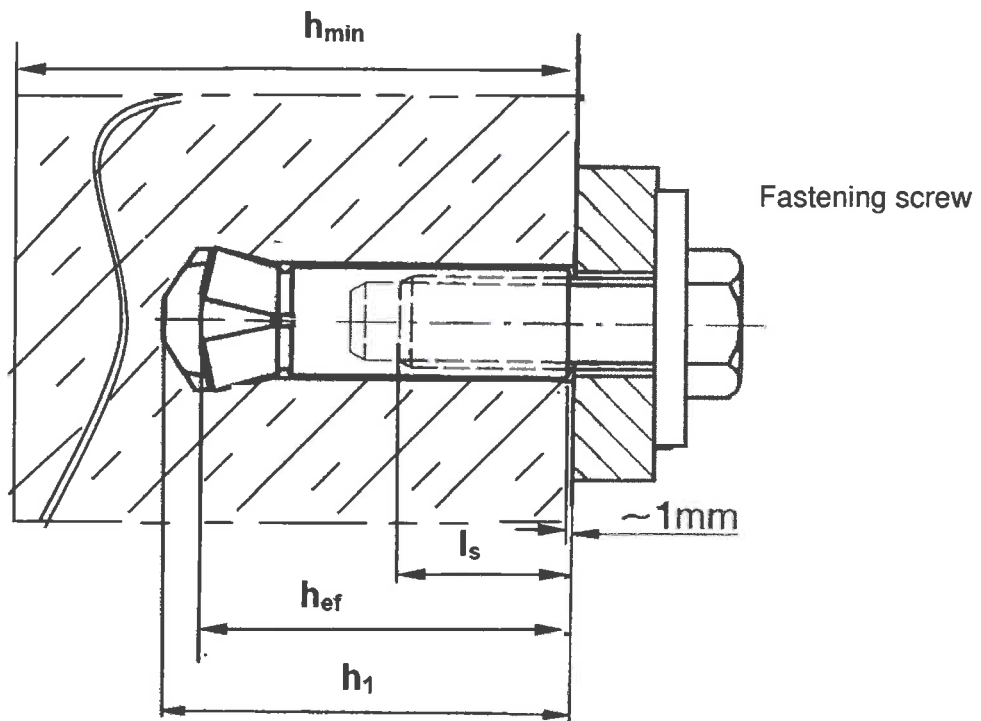

- $h_{ef}$ : Anchorage depth
- $l_s$ : Screw-in depth
- $h_1$ : Drill hole depth
- $h_{min}$ : minimal member thickness



fischer Zykon-Hammerset anchor FZEA II

Product and intended use

Annex 1

English translation prepared by DIBt

Marking e.g.:

	FZEA II 12x40	(galvanised steel)
	FZEA II 12x40 A4	(stainless steel)
	FZEA II 12x40 C	(high corrosion resistant steel)

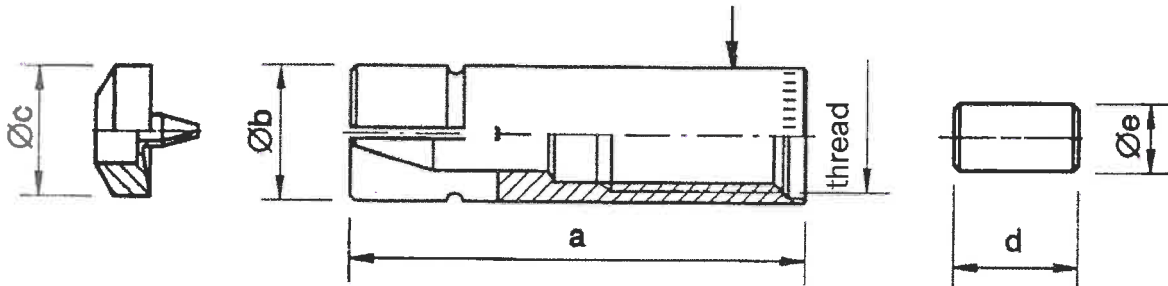

**Table 1: Dimensions [mm]**

Anchor type	thread	a [mm]	Øb [mm]	Øc [mm]	d [mm]	Øe [mm]
FZEA II 10 x 40 M8	M8	39	10	9,5	11	6,5
FZEA II 12 x 40 M10	M10		12	11,5		6,5
FZEA II 14 x 40 M12	M12		14	13,5		9,5

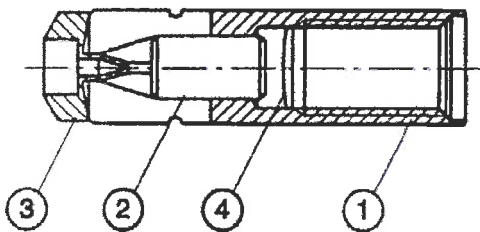

**Table 2: Materials**

Part	Designation	Material		
		FZEA II	FZEA II A4	FZEA II C
1	Expansion sleeve	Steel, EN 10277 EN ISO 4042 $\geq 5 \mu\text{m}$	stainless steel, EN 10088	high corrosion resistant steel EN 10088
2	Expansion pin	Steel, EN 10277 or EN ISO 10263 EN ISO 4042 $\geq 5 \mu\text{m}$	stainless steel, EN 10088	high corrosion resistant steel EN 10088
3	Distance part	plastic		
4	Safety disk	foil		
Requirements for the fastening screw / threaded rod <sup>1)</sup>		Steel, EN 10277 oder EN ISO 10263 EN ISO 4042 $\geq 5 \mu\text{m}$ minimum strength class 5.6	stainless steel EN 10088 minimale minimum strength class A50	high corrosion resistant steel EN 10088 minimum strength class A50

1) The length of the fastening screw shall be determined depending on the thickness of the fixture  $t_{\text{fix}}$ , admissible tolerances, existing thread length (=maximum screwing depth) and minimum screwing depth (according to Table 3)

fischer Zykon-Hammerset anchor FZEA II

Designations, Materials, Dimensions

Annex 2

English translation prepared by DIBt

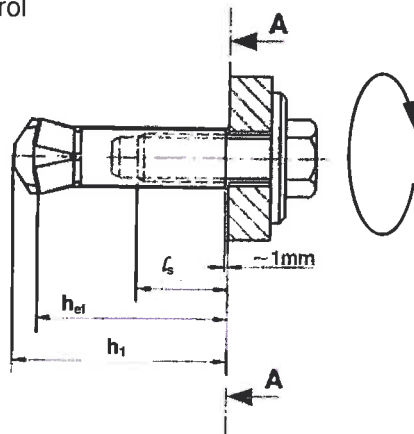
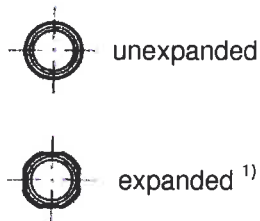

Description installation control  
plan view A-A



$h_{ef}$ : anchorage depth  
 $l_s$ : screw-in depth  
 $h_1$ : drill hole depth

$T_{max}$ .

<sup>1)</sup> By setting the anchor with the machine setting tool stop the rotation, otherwise a round flange is formed instead of the notch

Anchor type ..	FZEAII 10x40M8	FZEAII 12x40M10	FZEAII 14x40M12
Installation tools			
Universal drill 	FZUB 10x40	FZUB 12x40	FZUB 14x40
Impact thorn 	FZED 10x40	FZED 12x40	FZED 14x40
Machine setting tool <sup>1)</sup> 	FZEM 10x40	FZEM 12x40	FZEM 14x40

**Table 3: Installation and anchor parameters**

Anchor type	Drill hole depth $t^{2)}$ [mm]	Anchorage depth $h_{ef}$ [mm]	Fastening screw or threaded rod			
			Installation torque $T_{inst.}$ [Nm]		Installation torque $T_{inst.}$ [Nm]	
			FZEA II	FZEA II A4 FZEA II C	max	min
FZEA II 10 x 40 M8	43	40	< 10	< 15	17	11
FZEA II 12 x 40 M10	43	40	< 15	< 20	19	13
FZEA II 14 x 40 M12	43	40	< 20	< 40	21	15

<sup>2)</sup> Depends on the abrasion of the stopper of the universal drill, gets deeper with longer lifetime

**Table 4: Minimal member thickness and minimal edge- and spacing distance**

Anchor type and size		FZEA II 10x40 M8	FZEA II 12x40 M10	FZEA II 14x40 M12
Minimal member thickness	$h_{min}$ [mm]	80	80	80
Minimal spacing distance	$s_{min}$ [mm]	40	45	50
Minimal edge distance	$c_{min}$ [mm]	40	45	50

fischer Zykon-Hammerset anchor FZEA II

Installation characteristics and installation tools

Annex 3

**Table 5:** Design method A - Characteristic values to tension loads

FZEA II		FZEA II 10x40 M8	FZEA II 12x40 M10	FZEA II 14x40 M12
<b>Steel failure</b>				
Characteristic resistance FZEA II	$N_{Rk,s}$ [kN]	9,60	17,00	19,70
Characteristic resistance FZEA II A4, FZEA II C	$N_{Rk,s}$ [kN]	12,20	21,60	25,00
Partial safety factor	$\gamma_{Ms}^{2)}$	2,2 <sup>3)</sup> / 1,5		
<b>Pullout failure</b>				
Characteristic resistance in cracked concrete	$N_{Rk,p}$ [kN] C20/25	4	7,5	9
Characteristic resistance in non-cracked concrete	$N_{Rk,p}$ [kN] C20/25	9	9	9
Increasing factors for $N_{Rk,p}$ for cracked and non-cracked concrete	$\psi_c$	C30/37	1,22	
		C40/50	1,41	
		C50/60	1,55	
Partial safety factor	$\gamma_{Mp}^{2)}$	1,8 <sup>1)</sup>		
<b>Concrete cone failure</b>				
Effective anchorage depth	$h_{ef}$ [mm]	40	40	40
Minimal member thickness	$h_{min}$ [mm]	80	80	80
Spacing	$s_{cr,N}$ [mm]	120	120	120
Edge distance	$c_{cr,N}$ [mm]	60	60	60
Spacing (splitting)	$s_{cr,sp}$ [mm]	170	170	170
Edge distance (splitting)	$c_{cr,sp}$ [mm]	85	85	85
Partial safety factor	$\gamma_{Mp}^{2)}$	1,8 <sup>1)</sup>		

<sup>1)</sup> Including partial safety factor  $\gamma_2 = 1,2$

<sup>2)</sup> If there are no other national requirements

<sup>3)</sup>  $\gamma_{Ms} = 2,2$  for screws strength class A 50, otherwise  $\gamma_{Ms} = 1,5$

**Table 6:** Displacements of anchors due to tension load

FZEA II		FZEA II 10x40 M8	FZEA II 12x40 M10	FZEA II 14x40 M12
Tension load in cracked concrete	[kN]	1,56	2,93	3,50
Displacement	$\delta_{No}$ [mm]	1,30		
	$\delta_{N\infty}$ [mm]	1,40		
Tension load in non-cracked concrete	[kN]	3,52		
Displacement	$\delta_{No}$ [mm]	1,30		
	$\delta_{N\infty}$ [mm]	1,40		

fischer Zykon-Hammerset anchor FZEA II

Design method A  
Characteristic values to tension loads  
Displacements

Annex 4

English translation prepared by DIBt

**Table 7:** Design method A - Characteristic values to shear loads

FZEA II		FZEA II 10x40 M8	FZEA II 12x40 M10	FZEA II 14x40 M12
<b>Steel failure without lever arm</b>				
Characteristic resistance FZEA II	$V_{Rk,s}$ [kN]	8,30	13,60	19,10
Partial safety factor FZEA II	$\gamma_{Ms}^{1)}$	1,6 <sup>4)</sup> / 1,25		
Characteristic resistance FZEA II A4, FZEA II C	$V_{Rk,s}$ [kN]	10,00	15,00	20,60
Partial safety factor FZEA II A4, FZEA II C	$\gamma_{Ms}^{1)}$	2,6 <sup>5)</sup> / 1,25		
<b>Steel failure with lever arm</b>				
Characteristic resistance FZEA II <sup>3)</sup>	$M^0_{Rk,s}$ [Nm]	15	23	31
Partial safety factor FZEA II	$\gamma_{Ms}$	1,4 <sup>4)</sup> / 1,25		
Characteristic resistance FZEA II A4, FZEA II C <sup>3)</sup>	$M^0_{Rk,s}$ [Nm]	19	29	39
Partial safety factor FZEA II A4, FZEA II C	$\gamma_{Ms}$	2,5 <sup>5)</sup> / 1,25		
<b>Concrete pryout failure</b>				
Factor in equation (5.6) of ETAG 001 Annex C, 5.2.3.3	k	1,3		
Partial safety factor	$\gamma_{Mc}$	1,5 <sup>2)</sup>		
<b>Concrete edge failure</b>				
Effective length of anchor for shear	$l_f$ [mm]	40	40	40
Effective diameter of anchor	$d_{nom}$ [mm]	10	12	14
Partial safety factor	$\gamma_{Mc}^{1)}$	1,5 <sup>2)</sup>		

<sup>1)</sup> If there are no other national requirements

<sup>2)</sup> Including partial safety factor  $\gamma_2 = 1,0$

<sup>3)</sup> Thread diameter of the anchor decisive

<sup>4)</sup> Decisive for the screw respectively thread strength class 5.6, otherwise  $\gamma_{Ms} = 1,25$

<sup>5)</sup> Decisive for the screw respectively thread strength class A50, otherwise  $\gamma_{Ms} = 1,25$

**Table 8:** Displacements of anchors due to shear load

FZEA II		FZEA II 10x40 M8	FZEA II 12x40 M10	FZEA II 14x40 M12
Shear load in cracked an non-cracked concrete, FZEA II	V [kN]	4,70	7,60	10,70
Displacement	$\delta V_0$ [mm]	1,3	1,8	2,0
	$\delta V_\infty$ [mm]	1,9	2,6	3,0
Shear load in cracked an non-cracked concrete, FZEA II A4, FZEA II C	V [kN]	5,60	8,40	11,60
Displacement	$\delta V_0$ [mm]	1,8	2,0	2,0
	$\delta V_\infty$ [mm]	2,7	3,0	3,0

fischer Zykon-Hammerset anchor FZEA II

Design method A  
Characteristic values to shear loads  
Displacements

Annex 5

English translation prepared by DIBt

**Table 9:** Characteristic values to tension loads under fire exposure in cracked and non-cracked concrete C20/25 to C50/60

FZEA II, FZEA II A4, FZEA II C	FZEA II 10x40 M8			FZEA II 12x40 M10			FZEA II 14x40 M12						
	30	60	90	120	30	60	90	120	30	60	90	120	
Fire resistance duration [ min ]	R...												
<b>Steel failure:</b>													
Characteristic resistance	$N_{Rk,s,fi}$ [ kN ]	1,1	0,9	0,8	0,7	3,2	2,4	1,6	1,2	4,7	3,5	2,3	1,8
<b>Pullout failure:</b>													
Characteristic resistance in concrete C20/25 to C50/60	$N_{Rk,p,fi}$ [ kN ]	1,0			0,8	1,9			1,5	2,3			1,8
<b>Concrete cone failure:</b>													
Characteristic resistance in concrete C20/25 to C50/60	$N^0_{Rk,c,fi}$ [ kN ]	1,8			1,5	1,8			1,5	1,8			1,5
Spacing	$s_{cr,N}$	4 x $h_{ef}$											
	$s_{min}$ [ mm ]	40			45			50					
Edge Distance	$c_{cr,N}$	2 x $h_{ef}$											
	$c_{min}$ [ mm ]	40			45			50					
If fire attack is from more than one side, the edge distance of the anchor has to be bigger than 300 mm.													

In absence of other national regulations the partial safety factor for resistance under fire exposure  $\gamma_{M,fi} = 1,0$  is recommended.

fischer Zykon-Hammerset anchor FZEA II

Characteristic values to tension loads under fire exposure

Annex 6

English translation prepared by DIBt

**Table 10:** Characteristic values to shear loads under fire exposure in cracked and non-cracked concrete C20/25 to C50/60

FZEA II, FZEA II A4, FZEA II C	FZEA II 10x40 M8			FZEA II 12x40 M10			FZEA II 14x40 M12					
	30	60	90	120	30	60	90	120	30	60	90	120
Fire resistance duration R... [ min ]	30	60	90	120	30	60	90	120	30	60	90	120
<b>Steel failure without lever arm:</b>												
Characteristic resistance $V_{Rk,s,fi}$ [ kN ]	0,9	0,8	0,7	0,6	2,3	1,7	1,1	0,9	2,8	2,1	1,4	1,0
<b>Steel failure with lever arm:</b>												
Characteristic resistance $M^0_{Rk,s,fi}$ [ kN ]	1,1	0,9	0,8	0,7	4,1	3,1	2,1	1,5	7,3	5,4	3,6	2,7
<b>Concrete pryout failure:</b>												
In Equation (5.6) of ETAG 001, Annex C, 5.2.2.3 the k-factor of Table 7 and the relevant values of $N^0_{Rk,c,fi}$ of Table 9 have to be considered												
<b>Concrete edge failure:</b>												
The initial value $V^0_{Rk,c,fi}$ of the characteristic resistance in concrete C20/25 to C50/60 under fire exposure may be determined by: $V^0_{Rk,c,fi} = 0,25 \times V^0_{Rk,c}$ (R30, R 60, R90) $V^0_{Rk,c,fi} = 0,20 \times V^0_{Rk,c}$ (R120) with $V^0_{Rk,c}$ initial value of the characteristic resistance in cracked concrete C20/25 under normal temperature.												

In absence of other national regulations the partial safety factor for resistance under fire exposure  $\gamma_{M,fi} = 1.0$  is recommended.

fischer Zykon-Hammerset anchor FZEA II

Characteristic values to shear loads under fire exposure

Annex 7

English translation prepared by DIBt

Installation: Pre-positioned installation

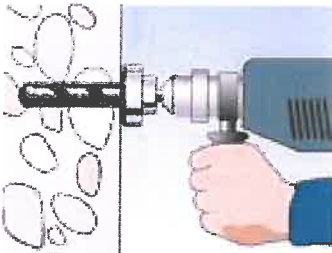

1.) Drilling of the hole cylindrically

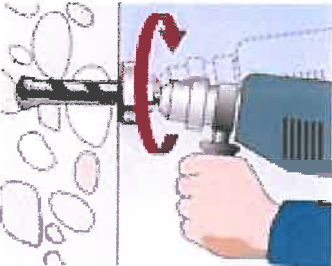

2.) 2-3 times rotating the drilling machine

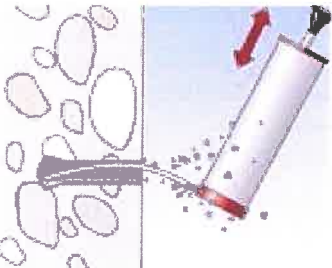

3.) Clearance of drill hole

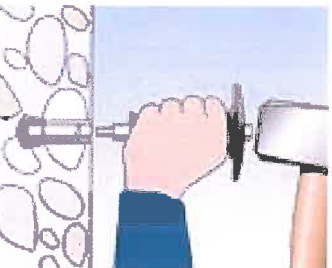

4.) Drive in the pin with the setting tool

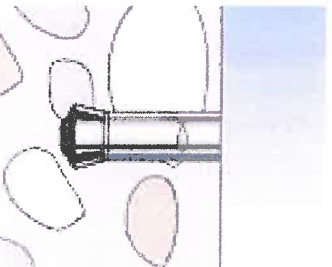

5.) Check of the setting notch for correct installation



expanded

fischer Zykon-Hammerset anchor FZEA II

Installation instructions

Annex 8