

Approval body for construction products
and types of construction

Bautechnisches Prüfamt

An institution established by the Federal and
Laender Governments



European Technical Assessment

ETA-16/0515
of 14 December 2017

English translation prepared by DIBt - Original version in German language

General Part

Technical Assessment Body issuing the
European Technical Assessment:

Deutsches Institut für Bautechnik

Trade name of the construction product

HVU2

Product family
to which the construction product belongs

Bonded Fastener for use in concrete

Manufacturer

Hilti AG Liechtenstein
Feldkircherstraße 100
9494 Schaan
FÜRSTENTUM LIECHTENSTEIN

Manufacturing plant

Hilti Corporation

This European Technical Assessment
contains

26 pages including 3 annexes which form an integral part
of this assessment

This European Technical Assessment is
issued in accordance with Regulation (EU)
No 305/2011, on the basis of

ETAG 001 Part 5: "Bonded anchors", April 2013,
used as EAD according to Article 66 Paragraph 3 of
Regulation (EU) No 305/2011.

This version replaces

ETA-16/0515 issued on 13 July 2017

The European Technical Assessment is issued by the Technical Assessment Body in its official language. Translations of this European Technical Assessment in other languages shall fully correspond to the original issued document and shall be identified as such.

Communication of this European Technical Assessment, including transmission by electronic means, shall be in full. However, partial reproduction may only be made with the written consent of the issuing Technical Assessment Body. Any partial reproduction shall be identified as such.

This European Technical Assessment may be withdrawn by the issuing Technical Assessment Body, in particular pursuant to information by the Commission in accordance with Article 25(3) of Regulation (EU) No 305/2011.

Specific Part

1 Technical description of the product

The Hilti HVU is a bonded anchor consisting of a mortar capsule Hilti HVU2 and a steel element. The steel element consist of

- an anchor rod Hilti HAS-(E) with washer and hexagon nut of sizes M8 to M20 or
- an internally threaded sleeve HIS-(R)N of sizes M8 to M16

The mortar capsule is placed in the hole and the steel element is driven by machine as specified in Annex B7.

The anchor rod is anchored via the bond between steel element, chemical mortar and concrete. The product description is given in Annex A.

2 Specification of the intended use in accordance with the applicable European Assessment Document

The performances given in Section 3 are only valid if the anchor is used in compliance with the specifications and conditions given in Annex B.

The verifications and assessment methods on which this European Technical Assessment is based lead to the assumption of a working life of the anchor of at least 50 years. The indications given on the working life cannot be interpreted as a guarantee given by the producer, but are to be regarded only as a means for choosing the right products in relation to the expected economically reasonable working life of the works.

3 Performance of the product and references to the methods used for its assessment

3.1 Mechanical resistance and stability (BWR 1)

Essential characteristic	Performance
Characteristic values under static and quasi-static action, Displacements	See Annex C 1 to C 9

3.2 Safety in case of fire (BWR 2)

Essential characteristic	Performance
Reaction to fire	Anchorage satisfy requirements for Class A1
Resistance to fire	No performance assessed

3.3 Hygiene, health and the environment (BWR 3)

Regarding dangerous substances there may be requirements (e.g. transposed European legislation and national laws, regulations and administrative provisions) applicable to the products falling within the scope of this European Technical Assessment. In order to meet the provisions of Regulation (EU) No 305/2011, these requirements need also to be complied with, when and where they apply.

3.4 Safety in use (BWR 4)

The essential characteristics regarding Safety in use are included under the Basic Works Requirement Mechanical resistance and stability.

English translation prepared by DIBt

4 Assessment and verification of constancy of performance (AVCP) system applied, with reference to its legal base

In accordance with guideline for European technical approval ETAG 001, April 2013 used as European Assessment Document (EAD) according to Article 66 Paragraph 3 of Regulation (EU) No 305/2011 the applicable European legal act is: [96/582/EC].

The system to be applied is: 1

5 Technical details necessary for the implementation of the AVCP system, as provided for in the applicable European Assessment Document

Technical details necessary for the implementation of the AVCP system are laid down in the control plan deposited at Deutsches Institut für Bautechnik.

Issued in Berlin on 14 December 2017 by Deutsches Institut für Bautechnik

BD Dipl.-Ing. Andreas Kummerow
Head of Department

beglaubigt:
Lange

Installed condition

Figure A1:
HAS-(E)...

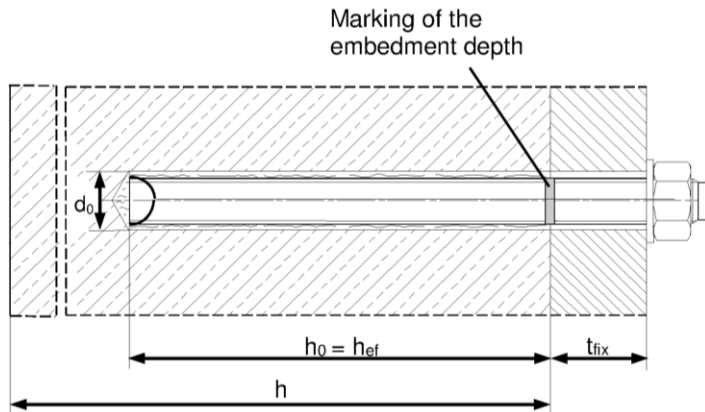
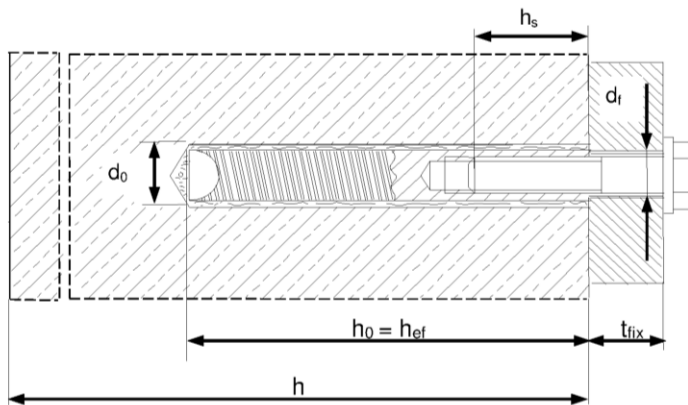

Figure A2:
Internally threaded sleeve HIS-(R)N



HVU2

Product description
Installed condition

Annex A1

Product description: Mortar capsule and steel elements

Adhesive anchor capsule HVU2 M8 to M24: resin and hardener with aggregate

Marking:
HVU2 M ...
Expiry date mm/yyyy



Steel elements

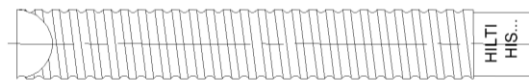
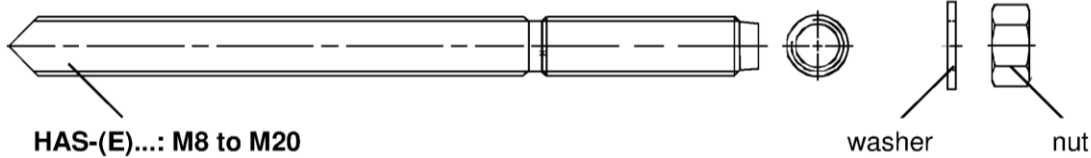

Internally threaded sleeve HIS-(R)N: M8 to M16

Dimensions according to Annex B6.

HVU2

Product description
Adhesive anchor capsule / Steel elements

Annex A2

Table A1: Materials

Designation	Material
Metal parts made of zinc coated steel	
HAS-(E)	M8 to M16: Strength class 5.8, $f_{uk} = 570 \text{ N/mm}^2$, $f_{yk} = 456 \text{ N/mm}^2$ M20: Strength class 5.8, $f_{uk} = 500 \text{ N/mm}^2$, $f_{yk} = 400 \text{ N/mm}^2$ M8 to M20: Strength class 8.8, $f_{uk} = 800 \text{ N/mm}^2$, $f_{yk} = 640 \text{ N/mm}^2$ Rupture elongation ($l_0 = 5d$) > 8% ductile Electroplated zinc coated $\geq 5 \mu\text{m}$, (F) hot dip galvanized $\geq 45 \mu\text{m}$
Internally threaded sleeve HIS-N	Electroplated zinc coated $\geq 5 \mu\text{m}$
Washer	Electroplated zinc coated $\geq 5 \mu\text{m}$, hot dip galvanized $\geq 45 \mu\text{m}$
Nut	Strength class of nut adapted to strength class of threaded rod. Electroplated zinc coated $\geq 5 \mu\text{m}$, hot dip galvanized $\geq 45 \mu\text{m}$
Metal parts made of stainless steel	
HAS-(E)R	M8 to M16: strength class 70, $f_{uk} = 700 \text{ N/mm}^2$, $f_{yk} = 500 \text{ N/mm}^2$ M20: strength class 70, $f_{uk} = 700 \text{ N/mm}^2$, $f_{yk} = 450 \text{ N/mm}^2$ Rupture elongation ($l_0 = 5d$) > 8% ductile Stainless steel 1.4401, 1.4404, 1.4578, 1.4571, 1.4439, 1.4362 EN 10088-1:2014
Internally threaded sleeve HIS-RN	Stainless steel 1.4401, 1.4571 EN 10088-1:2014
Washer	Stainless steel 1.4401, 1.4404, 1.4578, 1.4571, 1.4439, 1.4362 EN 10088-1:2014
Nut	Strength class of nut adapted to strength class of threaded rod. Stainless steel 1.4401, 1.4404, 1.4578, 1.4571, 1.4439, 1.4362 EN 10088-1:2014
Metal parts made of high corrosion resistant steel	
HAS-(E)HCR	M8 to M20: $f_{uk} = 800 \text{ N/mm}^2$, $f_{yk} = 640 \text{ N/mm}^2$ Rupture elongation ($l_0 = 5d$) > 8% ductile High corrosion resistant steel 1.4529, 1.4565 EN 10088-1:2014
Washer	High corrosion resistant steel 1.4529, 1.4565 EN 10088-1:2014
Nut	Strength class of nut adapted to strength class of threaded rod. High corrosion resistant steel 1.4529, 1.4565 EN 10088-1:2014

HVU2

Product description
Materials

Annex A3

Specifications of intended use

Anchorage subject to:

- Static and quasi static loading.





Base material:

- Reinforced or unreinforced normal weight concrete according to EN 206-1:2000.
- Strength classes C20/25 to C50/60 according to EN 206-1:2000.
- Cracked and non-cracked concrete.

Temperature in the base material:

- **At installation**
-10 °C to +40 °C
- **In-service**
 - Temperature range I: -40 °C to +40 °C
(max. long term temperature +24 °C and max. short term temperature +40 °C)
 - Temperature range II: -40 °C to +80 °C
(max. long term temperature +50 °C and max. short term temperature +80 °C)
 - Temperature range III: -40 °C to +120 °C
(max. long term temperature +72 °C and max. short term temperature +120 °C)

Table B1: Specifications of intended use

Elements	Foil capsule HVU2 with ...	
	Threaded rod HAS-(E)... 	HIS-(R)N 
Hammer drilling with hollow drill bit TE-CD or TE-YD 	M12 to M20	M8 to M16
Hammer drilling 	M8 to M20	M8 to M16
Diamond coring 	M10 to M20	M8 to M16

HVU2

Intended Use
Specifications

Annex B1

Use conditions (Environmental conditions):

- Structures subject to dry internal conditions (zinc coated steel, stainless steel or high corrosion resistant steel).
- Structures subject to external atmospheric exposure (including industrial and marine environment) and to permanently damp internal conditions, if no particular aggressive conditions exist (stainless steel or high corrosion resistant steel).
- Structures subject to external atmospheric exposure and to permanently damp internal conditions, if other particular aggressive conditions exist (high corrosion resistant steel).

Note: Particular aggressive conditions are e.g. permanent, alternating immersion in seawater or the splash zone of seawater, chloride atmosphere of indoor swimming pools or atmosphere with extreme chemical pollution (e.g. in desulphurization plants or road tunnels where de-icing products are used).

Design:

- Anchorages are designed under the responsibility of an engineer experienced in anchorages and concrete work.
- Verifiable calculation notes and drawings are prepared taking account of the loads to be anchored. The position of the anchor is indicated on the design drawings (e. g. position of the anchor relative to reinforcement or to supports, etc.).
- Anchorages under static or quasi-static loading are designed in accordance with:
EOTA Technical Report TR 029, 09/2010,
CEN/TS 1992-4:2009

Installation:

- Use category: dry or wet concrete (not in flooded holes).
- Drilling technique: hammer drilling, diamond coring (e.g. Hilti DD 30-W or other Hilti DD machines), hammer drilling with hollow drill bit TE-CD, TE-YD.
- Overhead installation is admissible.
- Anchor installation carried out by appropriately qualified personnel and under the supervision of the person responsible for technical matters of the site.

HVU2

Intended Use
Specifications

Annex B2

Table B2: Installation parameters of HAS-(E)...

HAS-(E)...		M8	M10	M12	M16	M20
Foil capsule HVU2 M...		8x80	10x90	12x110	16x125	20x170
Diameter of element	$d^{1)} = d_{nom}^{2)}$ [mm]	8	10	12	16	20
Nominal diameter of drill bit	d_0 [mm]	10	12	14	18	22
HAS-(E)...						
Effective embedment depth and drill hole depth	$h_{ef} = h_0$ [mm]	80	90	110	125	170
Maximum diameter of clearance hole in the fixture ³⁾	d_f [mm]	9	12	14	18	22
Minimum thickness of concrete member	h_{min} [mm]	110	120	140	160	220
Maximum torque moment	T_{max} [Nm]	10	20	40	80	150
Minimum spacing	s_{min} [mm]	40	50	60	75	90
Minimum edge distance	c_{min} [mm]	40	45	45	50	55

1) Parameter for design according to EOTA Technical Report TR 029.

2) Parameter for design according to CEN/TS 1992-4:2009.

3) For larger clearance hole see TR 029 section 1.1.

HAS-(E)...

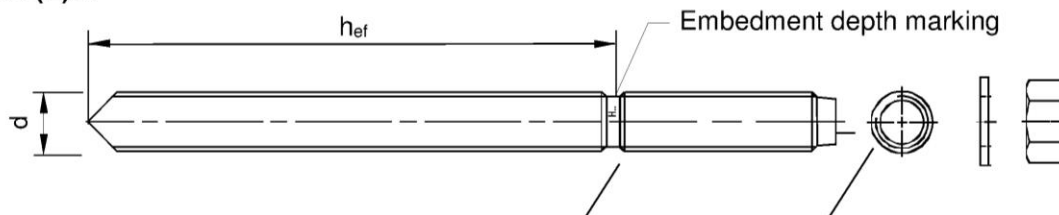

Marking:

identifying mark - H, embossing "1" HAS-(E)
 identifying mark - H, embossing "=" HAS-(E)R
 identifying mark - H, embossing "CR" HAS-(E)HCR

HVU2

Intended Use
Installation parameters

Annex B3

Table B3: Installation parameters of internally threaded sleeve HIS-(R)N

Internally threaded sleeve HIS-(R)N		M8	M10	M12	M16
Foil capsule HVU2 M...		10x90	12x110	16x125	20x170
Outer diameter of sleeve	$d^{1)} = d_{nom}^{2)}$ [mm]	12,5	16,5	20,5	25,4
Nominal diameter of drill bit	d_0 [mm]	14	18	22	28
Effective embedment depth and drill hole depth	$h_{ef} = h_0$ [mm]	90	110	125	170
Maximum diameter of clearance hole in the fixture ³⁾	d_f [mm]	9	12	14	18
Minimum thickness of concrete member	h_{min} [mm]	120	150	170	230
Maximum torque moment	T_{max} [Nm]	10	20	40	80
Thread engagement length min-max	h_s [mm]	8-20	10-25	12-30	16-40
Minimum spacing	s_{min} [mm]	60	75	90	115
Minimum edge distance	c_{min} [mm]	40	45	55	65

1) Parameter for design according to EOTA Technical Report TR 029.

2) Parameter for design according to CEN/TS 1992-4:2009.

3) For larger clearance hole see TR 029 section 1.1.

Internally threaded sleeve HIS-(R)N...

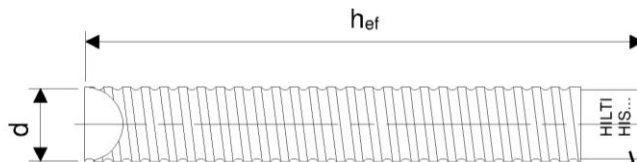

Marking:

Identifying mark - HILTI and
embossing "HIS-N" (for zinc coated steel)
embossing "HIS-RN" (for stainless steel)

HVU2

Intended Use
Installation parameters

Annex B4

Table B4: Minimum curing time







Temperature in the base material T	Minimum curing time t_{cure}
-10 °C to -6 °C	5 hours
-5 °C to -1 °C	3 hours
0 °C to 4 °C	40 min
5 °C to 9 °C	20 min
10 °C to 19 °C	10 min
20 °C to 40 °C	5 min

HVU2

Intended Use
Minimum curing time

Annex B5

Table B5: Parameters of drilling and cleaning tools

Elements		Drill and clean			
HAS-(E)...	HIS-(R)N	Hammer drilling		Diamond coring	Brush
			Hollow drill bit TE-CD, TE-YD		
					
Size	Name	d ₀ [mm]	d ₀ [mm]	d ₀ [mm]	HIT-RB
M8	-	10	-	-	-
M10	-	12	-	12	12
M12	M8	14	14	14	14
M16	M10	18	18	18	18
M20	M12	22	22	22	22
-	M16	28	28	28	28

Cleaning alternatives

Manual Cleaning (MC):

Hilti hand pump for blowing out drill holes with diameters d₀ ≤ 18 mm and drill hole depths h₀ ≤ 10 d.



Compressed Air Cleaning (CAC):

Air nozzle with an orifice opening of minimum 3,5 mm in diameter.



Automatic Cleaning (AC):

Cleaning is performed during drilling with Hilti TE-CD and TE-YD drilling system including vacuum cleaner.



HVU2

Intended Use
Cleaning tools

Annex B6

Table B6: Parameters of setting tools HAS-(E)...







Elements	Setting tools	Operating mode	
HAS-(E) M8 to M20 	 TE-C 1/2" / TE-FY 3/4" TE(-A) HAS-(E) with double nut and TE-C 1/2" or TE-FY 3/4" adapter	Rotary hammer tool in rotation hammer mode	
HAS M8 to M16 	 HAS M8-16 SF(H)	Drill driver in rotation mode or rotation hammer mode	
	 HAS M8-16 TE-C HVU2 M8-M16 TE(-A)	HAS with setting tool delivered in the HAS box and TE-C HVU2 adapter	Rotary hammer tool in rotation hammer mode
	 TE-C HEX TE(-A)	HAS with TE-C HEX adapter	Rotary hammer tool in rotation hammer mode
HAS-E M20 	 TE-Y-E TE(-A)	Rotary hammer tool in rotation hammer mode	

Table B7: Parameters of setting tools HIS-(R)N...

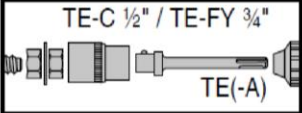
Elements	Setting tools	Setting mode
HIS-(R)N M8 to M16 	 TE-C 1/2" / TE-FY 3/4" TE(-A) HIS-S	HIS-N with HIS-S and TE-C 1/2" or TE-FY 3/4" adapter
	 TE-C 1/2" / TE-FY 3/4" TE(-A)	HIS-N with screw and TE-C 1/2" or TE-FY 3/4" adapter

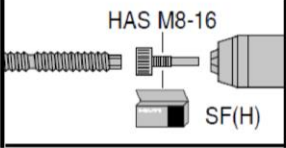
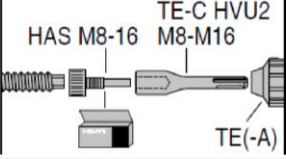
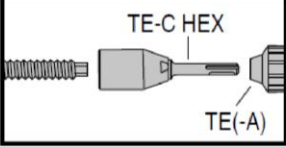
HVU2

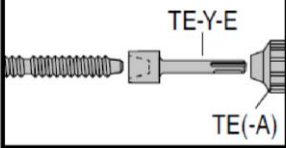
Intended Use
Setting tools

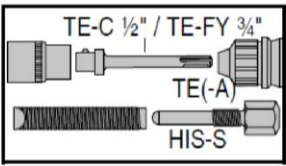
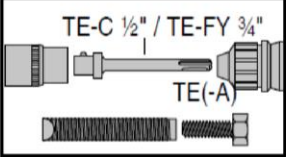
Annex B7

Installation instruction

Hole drilling

a) Hammer drilling: For dry or wet concrete.

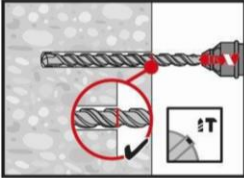

Drill hole to the required embedment depth with a hammer drill set in rotation-hammer mode using an appropriately sized carbide drill bit.

b) Hammer drilling with Hilti hollow drill bit: For dry and wet concrete.

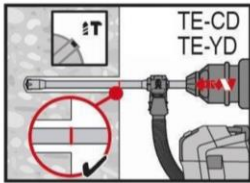

Drill hole to the required embedment depth with an appropriately sized Hilti TE-CD or TE-YD hollow drill bit with Hilti vacuum attachment. This drilling system removes the dust and cleans the drill hole during drilling when used in accordance with the user's manual. After drilling is completed, proceed to the "setting the element" step in the installation instruction.

c) Diamond coring: For dry or wet concrete.

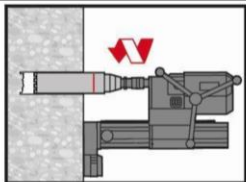

Diamond coring is permissible when suitable diamond core drilling machines and the corresponding core bits are used.

Check setting depth

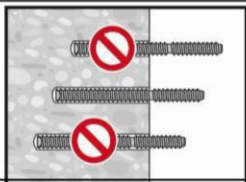

Check the setting depth with the marked element. The element has to fit in the hole until the required embedment depth, not deeper. If it is not possible to insert the element to the required embedment depth, drill deeper.

Drill hole cleaning: Just before setting an anchor, the drill hole must be free of dust and debris. Inadequate hole cleaning = poor load values.

Manual Cleaning (MC): For drill hole diameters $d_0 \leq 18$ mm and drill hole depths $h_0 \leq 10$ d.

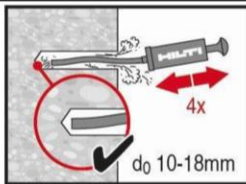

The Hilti hand pump may be used for blowing out drill holes. Blow out at least 4 times from the back of the drill hole until return air stream is free of noticeable dust.

Compressed Air Cleaning (CAC): For all drill hole diameters d_0 and all drill hole depths h_0 .

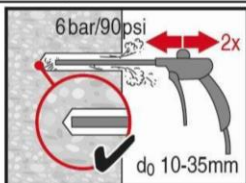

Blow 2 times from the back of the hole (if needed with nozzle extension) over the whole length with oil-free compressed air (min. 6 bar at 6 m³/h) until return air stream is free of noticeable dust.

HVU2

Intended Use
Installation instructions

Annex B8

Cleaning of hammer drilled flooded holes and diamond cored holes:

For all drill hole diameters d_0 and all drill hole depths h_0 .

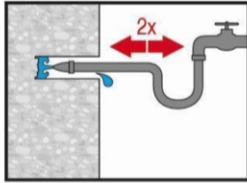

Flush 2 times by inserting a water hose (water-line pressure) to the back of the hole until water runs clear.

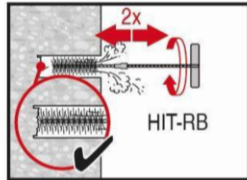

Brush 2 times with the specified brush (see table B5) by inserting the steel brush Hilti HIT-RB to the back of the hole (if needed with extension) in a twisting motion and removing it.
The brush must produce natural resistance as it enters the drill hole (brush $\varnothing \geq$ drill hole \varnothing) - if not, the brush is too small and must be replaced with the proper brush diameter.

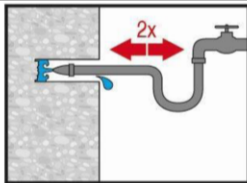

Flush 2 times by inserting a water hose (water-line pressure) to the back of the hole until water runs clear.

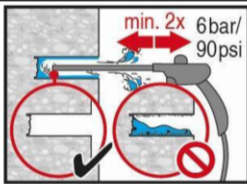

Blow 2 times from the back of the hole (if needed with nozzle extension) over the whole length with oil-free compressed air (min. 6 bar at 6 m³/h) until return air stream is free of noticeable dust and water.

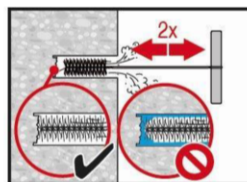

Brush 2 times with the specified brush (see table B5) by inserting the steel brush Hilti HIT-RB to the back of the hole (if needed with extension) in a twisting motion and removing it.
The brush must produce natural resistance as it enters the drill hole (brush $\varnothing \geq$ drill hole \varnothing) - if not, the brush is too small and must be replaced with the proper brush diameter.

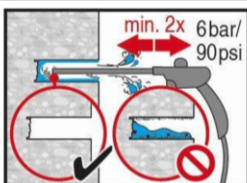

Blow again with compressed air 2 times until return air stream is free of noticeable dust and water.

HVU2

Intended Use
Installation instructions

Annex B9

Setting the element

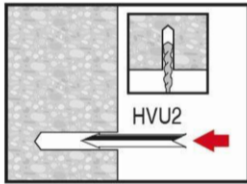

Insert the foil capsule with the peak ahead to the back of the hole.

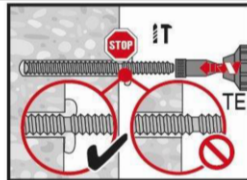

Drive the anchor rod with the plugged tool into the hole, applying moderate pressure. Rotary hammer tool in rotation hammer mode (450 RPM to maximum 1300 RPM). Setting tool see Annexes B4 and B5. After reaching the embedment depth switch off setting machine immediately.

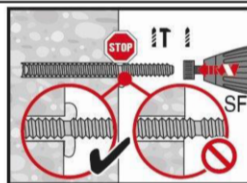

For HAS-(E) M8 to M16 a drill driver in rotation mode or rotation hammer mode can be used.

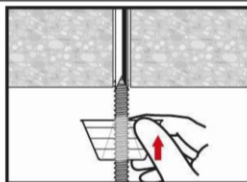

Overhead installation.
For overhead installation use the overhead dripping cup HIT-OHC.

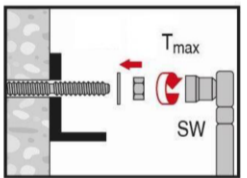

Loading the anchor: After required curing time t_{cure} (see Table B4) the anchor can be loaded. The applied installation torque shall not exceed the values T_{max} given in Table B2 and B3.

HVU2

Intended Use
Installation instructions

Annex B10

Table C1: Characteristic resistance for HAS-(E) under tension load in concrete

HAS-(E)...		M8	M10	M12	M16	M20	
Installation safety factor							
Hammer drilling and drilling with hollow drill bit TE-CD or TE-YD	$\gamma_2^{(1)} = \gamma_{inst}^{(2)}$	[-]		1,0			
Diamond coring	$\gamma_2^{(1)} = \gamma_{inst}^{(2)}$	[-]		1,0			
Steel failure							
Characteristic resistance HAS-(E) 5.8	$N_{Rk,s}$	[kN]	18,9	30,1	43,4	82,2	112,2
Partial safety factor	$\gamma_{Ms,N}^{(3)}$	[-]		1,50			
Characteristic resistance HAS-(E) 8.8	$N_{Rk,s}$	[kN]	26,5	42,2	61,0	115,4	179,5
Partial safety factor	$\gamma_{Ms,N}^{(3)}$	[-]		1,50			
Characteristic resistance HAS-R	$N_{Rk,s}$	[kN]	23,2	37,0	53,3	100,9	157,0
Partial safety factor	$\gamma_{Ms,N}^{(3)}$	[-]		1,68	1,68	1,68	1,87
Characteristic resistance HAS-HCR	$N_{Rk,s}$	[kN]	26,5	42,2	61,0	115,4	179,5
Partial safety factor	$\gamma_{Ms,N}^{(3)}$	[-]		1,50			
Combined pullout and concrete cone failure							
Characteristic bond resistance in non-cracked concrete C20/25 in hammer drilled holes							
Temperature range I: 40 °C / 24 °C	$\tau_{Rk,ucr}$	[N/mm ²]	12,0	16,0			
Temperature range II: 80 °C / 50 °C	$\tau_{Rk,ucr}$	[N/mm ²]	9,5	13,0			
Temperature range III: 120 °C / 72 °C	$\tau_{Rk,ucr}$	[N/mm ²]	6,0	7,5			
Characteristic bond resistance in non-cracked concrete C20/25 in hammer drilled holes with hollow drill bit TE-CD or TE-YD							
Temperature range I: 40 °C / 24 °C	$\tau_{Rk,ucr}$	[N/mm ²]	-	16,0			
Temperature range II: 80 °C / 50 °C	$\tau_{Rk,ucr}$	[N/mm ²]	-	13,0			
Temperature range III: 120 °C / 72 °C	$\tau_{Rk,ucr}$	[N/mm ²]	-	7,5			
Characteristic bond resistance in non-cracked concrete C20/25 in diamond cored holes							
Temperature range I: 40 °C / 24 °C	$\tau_{Rk,ucr}$	[N/mm ²]	-	14,0			
Temperature range II: 80 °C / 50 °C	$\tau_{Rk,ucr}$	[N/mm ²]	-	12,0			
Temperature range III: 120 °C / 72 °C	$\tau_{Rk,ucr}$	[N/mm ²]	-	6,5			
Increasing factors for $\tau_{Rk,ucr}$ in concrete	ψ_c	C30/37	1,08				
		C40/50	1,15				
		C50/60	1,20				
Factor acc. to section 6.2.2.3 of CEN/TS 1992-4:2009 part 5	$k_8^{(2)}$	[-]		10,1			

HVU2

Performances

Characteristic resistance under tension load in concrete
Design according to EOTA Technical Report TR 029, 09/2010 or CEN/TS 1992-4:2009

Annex C1

Table C1: continued

HAS-(E)...	M8	M10	M12	M16	M20
Characteristic bond resistance in cracked concrete C20/25 in hammer drilled holes					
Temperature range I: 40 °C / 24 °C	$\tau_{Rk,cr}$	[N/mm ²]	5,0	8,5	
Temperature range II: 80 °C / 50 °C	$\tau_{Rk,cr}$	[N/mm ²]	4,0	6,5	
Temperature range III: 120 °C / 72 °C	$\tau_{Rk,cr}$	[N/mm ²]	2,5	4,0	
Characteristic bond resistance in cracked concrete C20/25 in hammer drilled holes with hollow drill bit TE-CD or TE-YD					
Temperature range I: 40 °C / 24 °C	$\tau_{Rk,cr}$	[N/mm ²]	-	8,5	
Temperature range II: 80 °C / 50 °C	$\tau_{Rk,cr}$	[N/mm ²]	-	6,5	
Temperature range III: 120 °C / 72 °C	$\tau_{Rk,cr}$	[N/mm ²]	-	4,0	
Increasing factors for $\tau_{Rk,cr}$ in concrete for hammer drilled holes and hollow drill bit TE-CD or TE-YD	ψ_c	C30/37	1,04		
		C40/50	1,07		
		C50/60	1,10		
Characteristic bond resistance in cracked concrete C20/25 in diamond cored holes					
Temperature range I: 40 °C / 24 °C	$\tau_{Rk,cr}$	[N/mm ²]	-	7,0	
Temperature range II: 80 °C / 50 °C	$\tau_{Rk,cr}$	[N/mm ²]	-	6,0	
Temperature range III: 120 °C / 72 °C	$\tau_{Rk,cr}$	[N/mm ²]	-	3,5	
Increasing factors for $\tau_{Rk,cr}$ in concrete for diamond cored holes	ψ_c	C50/60	1,0		
Factor acc. to section 6.2.3 of CEN/TS 1992-4:2009 part 5	$k_{cr}^{(2)}$	[-]	7,2		
Concrete cone failure					
Factor acc. to section 6.2.2.3 of CEN/TS 1992-4:2009 part 5	$k_{ucr}^{(2)}$	[-]	10,1		
	$k_{cr}^{(2)}$		7,2		
Edge distance	$c_{cr,N}$	[mm]	$1,5 \cdot h_{ef}$		
Spacing	$s_{cr,N}$	[mm]	$3,0 \cdot h_{ef}$		

HVU2

Performances

Characteristic resistance under tension load in concrete
Design according to EOTA Technical Report TR 029, 09/2010 or CEN/TS 1992-4:2009

Annex C2

Table C1: continued

HAS-(E)...		M8	M10	M12	M16	M20
Splitting failure						
Factor acc. to section 6.2.2.3 of CEN/TS 1992-4:2009 part 5	$k_{ucr}^{2)}$	[-]			10,1	
	$k_{cr}^{2)}$	[-]			7,2	
Edge distance $C_{cr,sp}$ [mm] for	$h / h_{ef} \geq 2,0$	$1,0 \cdot h_{ef}$				
	$2,0 > h / h_{ef} > 1,3$	$4,6 h_{ef} - 1,8 h$				
	$h / h_{ef} \leq 1,3$	$2,26 h_{ef}$				
Spacing	$S_{cr,sp}$	[mm]			$2 \cdot C_{cr,sp}$	

¹⁾ Parameter for design according to EOTA Technical Report TR 029.

²⁾ Parameter for design according to CEN/TS 1992-4:2009.

³⁾ In absence of national regulations.

HVU2

Performances

Characteristic resistance under tension load in concrete
Design according to EOTA Technical Report TR 029, 09/2010 or CEN/TS 1992-4:2009

Annex C3

Table C2: Characteristic resistance for internally threaded sleeve HIS-(R)N under tension load in concrete

HIS-(R)N		M8	M10	M12	M16	
Installation safety factor						
Hammer drilling and drilling with hollow drill bit TE-CD or TE-YD	$\gamma_2^{1)} = \gamma_{inst}^{2)}$	[-]	1,0			
Diamond coring	$\gamma_2^{1)} = \gamma_{inst}^{2)}$	[-]	1,0			
Steel failure						
Characteristic resistance HIS-N with with screw or threaded rod grade 8.8	$N_{Rk,s}$	[kN]	25	46	67	125
Partial safety factor	$\gamma_{Ms,N}^{3)}$	[-]	1,5			
Characteristic resistance HIS-RN with with screw or threaded rod grade 70	$N_{Rk,s}$	[kN]	26	41	59	110
Partial safety factor	$\gamma_{Ms,N}^{3)}$	[-]	1,87			
Combined pullout and concrete cone failure						
Diameter of anchor	d	[mm]	12,5	16,5	20,5	25,4
Characteristic bond resistance in non-cracked concrete C20/25 in hammer drilled holes and hammer drilled holes with hollow drill bit TE-CD or TE-YD						
Temperature range I: 40 °C / 24 °C	$\tau_{Rk,ucr}$	[N/mm ²]	11,0			
Temperature range II: 80 °C / 50 °C	$\tau_{Rk,ucr}$	[N/mm ²]	9,0			
Temperature range III: 120 °C / 72 °C	$\tau_{Rk,ucr}$	[N/mm ²]	5,5			
Characteristic bond resistance in non-cracked concrete C20/25 in diamond cored holes						
Temperature range I: 40 °C / 24 °C	$\tau_{Rk,ucr}$	[N/mm ²]	11,0			
Temperature range II: 80 °C / 50 °C	$\tau_{Rk,ucr}$	[N/mm ²]	9,0			
Temperature range III: 120 °C / 72 °C	$\tau_{Rk,ucr}$	[N/mm ²]	5,5			
Increasing factors for $\tau_{Rk,ucr}$ in concrete	ψ_c	C50/60	1,0			
Factor acc. to section 6.2.2.3 of CEN/TS 1992-4:2009 part 5	$k_8^{2)}$	[-]	10,1			

HVU2

Performances

Characteristic resistance under tension load in concrete
Design according to EOTA Technical Report TR 029, 09/2010 or CEN/TS 1992-4:2009

Annex C4

Table C2: continued

HIS-(R)N			M8	M10	M12	M16
Characteristic bond resistance in cracked concrete C20/25 in hammer drilled holes and hammer drilled holes with hollow drill bit TE-CD or TE-YD						
Temperature range I: 40 °C / 24 °C	$\tau_{Rk,cr}$	[N/mm ²]	6,5			
Temperature range II: 80 °C / 50 °C	$\tau_{Rk,cr}$	[N/mm ²]	5,0			
Temperature range III: 120 °C / 72 °C	$\tau_{Rk,cr}$	[N/mm ²]	3,0			
Increasing factors for $\tau_{Rk,cr}$ in concrete for hammer drilled holes and hollow drill bit TE-CD or TE-YD	ψ_c	C30/37	1,08			
		C40/50	1,15			
		C50/60	1,20			
Characteristic bond resistance in cracked concrete C20/25 in diamond cored holes						
Temperature range I: 40 °C / 24 °C	$\tau_{Rk,cr}$	[N/mm ²]	4,5			
Temperature range II: 80 °C / 50 °C	$\tau_{Rk,cr}$	[N/mm ²]	3,5			
Temperature range III: 120 °C / 72 °C	$\tau_{Rk,cr}$	[N/mm ²]	2,5			
Increasing factors for $\tau_{Rk,cr}$ in concrete for diamond cored holes	ψ_c	C50/60	1,0			
Factor acc. to section 6.2.2.3 of CEN/TS 1992-4:2009 part 5	$k_8^{2)}$	[-]	7,2			
Concrete cone failure						
Factor acc. to section 6.2.3 of CEN/TS 1992-4:2009 part 5	$k_{ucr}^{2)}$	[-]	10,1			
	$k_{cr}^{2)}$	[-]	7,2			
Edge distance	$c_{cr,N}$	[mm]	$1,5 \cdot h_{ef}$			
Spacing	$s_{cr,N}$	[mm]	$3,0 \cdot h_{ef}$			
Splitting failure						
Factor acc. to section 6.2.3 of CEN/TS 1992-4:2009 part 5	$k_{ucr}^{2)}$	[-]	10,1			
	$k_{cr}^{2)}$	[-]	7,2			
Edge distance $c_{cr,sp}$ [mm] for	$h / h_{ef} \geq 2,0$		$1,0 \cdot h_{ef}$			
	$2,0 > h / h_{ef} > 1,3$		$4,6 h_{ef} - 1,8 h$			
	$h / h_{ef} \leq 1,3$		$2,26 h_{ef}$			
Spacing	$s_{cr,sp}$	[mm]	$2 \cdot c_{cr,sp}$			

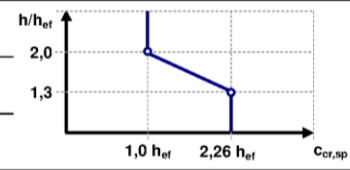

1) Parameter for design according to EOTA Technical Report TR 029.
2) Parameter for design according to CEN/TS 1992-4:2009.
3) In absence of national regulations.

HVU2

Performances
Characteristic resistance under tension load in concrete
Design according to EOTA Technical Report TR 029, 09/2010 or CEN/TS 1992-4:2009

Annex C5

Table C3: Characteristic resistance for HAS-(E) under shear load in concrete

HAS-(E)...		M8	M10	M12	M16	M20
Installation safety factor						
Hammer drilling and drilling with hollow drill bit TE-CD or TE-YD	$\gamma_2^{1)} = \gamma_{inst}^{2)}$ [-]	1,0				
Diamond coring	$\gamma_2^{1)} = \gamma_{inst}^{2)}$ [-]	1,0				
Steel failure without lever arm						
Characteristic resistance HAS-(E) 5.8	$V_{Rk,s}$ [kN]	9,5	15,1	21,7	41,1	56,1
Partial safety factor	$\gamma_{Ms,V}^{3)}$ [-]	1,25				
Characteristic resistance HAS-(E) 8.8	$V_{Rk,s}$ [kN]	13,3	21,1	30,5	57,7	89,7
Partial safety factor	$\gamma_{Ms,V}^{3)}$ [-]	1,25				
Characteristic resistance HAS-R	$V_{Rk,s}$ [kN]	11,6	18,5	26,7	50,5	78,5
Partial safety factor	$\gamma_{Ms,V}^{3)}$ [-]	1,4				1,56
Characteristic resistance HAS-HCR	$V_{Rk,s}$ [kN]	13,3	21,1	30,5	57,7	89,7
Partial safety factor	$\gamma_{Ms,V}^{3)}$ [-]	1,25				
Ductility factor	$k_2^{2)}$ [-]	1,0				
Steel failure with lever arm						
Characteristic resistance HAS-(E) 5.8	$M^0_{Rk,s}$ [kN]	18	37	64	167	284
Partial safety factor	$\gamma_{Ms,V}^{3)}$ [-]	1,25				
Characteristic resistance HAS-(E) 8.8	$M^0_{Rk,s}$ [kN]	26	53	90	234	455
Partial safety factor	$\gamma_{Ms,V}^{3)}$ [-]	1,25				
Characteristic resistance HAS-R	$M^0_{Rk,s}$ [kN]	23	45	79	205	398
Partial safety factor	$\gamma_{Ms,V}^{3)}$ [-]	1,4				1,56
Characteristic resistance HAS-HCR	$M^0_{Rk,s}$ [kN]	26	52	90	234	455
Partial safety factor	$\gamma_{Ms,V}^{3)}$ [-]	1,25				
Ductility factor	$k_2^{2)}$ [-]	1,0				
Concrete pry-out failure						
Pry-out factor	$k^1) = k_3^{2)}$ [-]	2,0				
Concrete edge failure						
Effective length of anchor	l_f [mm]	80	90	110	125	170
The value of h_{ef} for calculation in equations (5.8a) and (5.8b) of Technical Report TR 029 is limited by:	h_{ef} [mm]	$\min^1) (h_{ef}; 8 \cdot d),$ $\min^2) (h_{ef}; 8 \cdot d_{nom})$				
Diameter of anchor	d [mm]	8	10	12	16	20

¹⁾ Parameter for design according to EOTA Technical Report TR 029.

²⁾ Parameter for design according to CEN/TS 1992-4:2009.

³⁾ In absence of national regulations.

HVU2

Performances

Characteristic resistance under shear load in concrete
Design according to EOTA Technical Report TR 029, 09/2010 or CEN/TS 1992-4:2009

Annex C6

Table C4: Characteristic resistance for internally threaded sleeve HIS-(R)N under shear load in concrete

HIS-(R)N		M8	M10	M12	M16
Installation safety factor					
Hammer drilling and drilling with hollow drill bit TE-CD or TE-YD	$\gamma_2^{(1)} = \gamma_{Inst}^{(2)}$ [-]	1,0			
Diamond coring	$\gamma_2^{(1)} = \gamma_{Inst}^{(2)}$ [-]	1,0			
Steel failure without lever arm					
Characteristic resistance HIS-N with screw or threaded rod grade 8.8	$V_{Rk,s}$ [kN]	13	23	34	63
Partial safety factor	$\gamma_{Ms,V}^{(3)}$ [-]	1,25			
Characteristic resistance HIS-RN with screw or threaded rod grade 70	$V_{Rk,s}$ [kN]	13	20	30	55
Partial safety factor	$\gamma_{Ms,V}^{(3)}$ [-]	1,56			
Ductility factor	$k_2^{(2)}$ [-]	1,0			
Steel failure with lever arm					
Characteristic resistance HIS-N with screw grade 8.8	$M^0_{Rk,s}$ [Nm]	30	60	105	266
Partial safety factor	$\gamma_{Ms,V}^{(3)}$ [-]	1,25			
Characteristic resistance HIS-RN with screw grade 70	$M^0_{Rk,s}$ [Nm]	26	52	92	233
Partial safety factor	$\gamma_{Ms,V}^{(3)}$ [-]	1,56			
Ductility factor	$k_2^{(2)}$ [-]	1,0			
Concrete pry-out failure					
Pry-out factor	$k^{(1)} = k_3^{(2)}$ [-]	2,0			
Concrete edge failure					
Effective length of anchor	l_f [mm]	90	110	125	170
Diameter of anchor	d [mm]	12,5	16,5	20,5	25,4

1) Parameter for design according to EOTA Technical Report TR 029.

2) Parameter for design according to CEN/TS 1992-4:2009.

3) In absence of national regulations.

HVU2

Performances

Characteristic resistance under shear load in concrete
Design according to EOTA Technical Report TR 029, 09/2010 or CEN/TS 1992-4:2009

Annex C7

Table C5: Displacements for HAS-(E) under tension load¹⁾

HAS-(E)-...	M8	M10	M12	M16	M20
Non-cracked concrete					
Temperature range I to III					
Displacement δ_{N0} -factor [mm/(N/mm ²)]				0,06	
Displacement $\delta_{N\infty}$ -factor [mm/(N/mm ²)]				0,10	
Cracked concrete					
Temperature range I to III					
Displacement δ_{N0} -factor [mm/(N/mm ²)]				0,10	
Displacement $\delta_{N\infty}$ -factor [mm/(N/mm ²)]				0,14	

¹⁾ Calculation of the displacement

$$\delta_{N0} = \delta_{N0\text{-factor}} \cdot \tau; \quad \delta_{N\infty} = \delta_{N\infty\text{-factor}} \cdot \tau \quad (\tau: \text{action bond strength}).$$

Table C6: Displacements for HAS-(E) under shear load¹⁾

HAS-(E)-...	M8	M10	M12	M16	M20
Displacement δ_{V0} -factor [mm/kN]	0,06	0,06	0,05	0,04	0,04
Displacement $\delta_{V\infty}$ -factor [mm/kN]	0,09	0,08	0,08	0,06	0,06

¹⁾ Calculation of the displacement

$$\delta_{V0} = \delta_{V0\text{-factor}} \cdot V; \quad \delta_{V\infty} = \delta_{V\infty\text{-factor}} \cdot V \quad (V: \text{action shear load}).$$

HVU2

Performances
Displacements

Annex C8

Table C7: Displacements for internally threaded sleeves HIS-(R)N under tension load¹⁾

HIS-(R)N			M8	M10	M12	M16
Non-cracked concrete						
Temperature range I to III						
Displacement	δ_{N0} -factor	[mm/10kN]			0,05	
Displacement	$\delta_{N\infty}$ -factor	[mm/10kN]			0,10	
Cracked concrete						
Temperature range I to III						
Displacement	δ_{N0} -factor	[mm/10kN]			0,13	
Displacement	$\delta_{N\infty}$ -factor	[mm/10kN]			0,15	

¹⁾ Calculation of the displacement

$$\delta_{N0} = \delta_{N0}\text{-factor} \cdot N; \quad \delta_{N\infty} = \delta_{N\infty}\text{-factor} \cdot N \quad (N: \text{action tension load}).$$

Table C8: Displacements for internally threaded sleeves HIS-(R)N under shear load¹⁾

HIS-(R)N			M8	M10	M12	M16
Displacement	δ_{V0} -factor	[mm/kN]	0,06	0,06	0,05	0,04
Displacement	$\delta_{V\infty}$ -factor	[mm/kN]	0,09	0,08	0,08	0,06

¹⁾ Calculation of the displacement

$$\delta_{V0} = \delta_{V0}\text{-factor} \cdot V; \quad \delta_{V\infty} = \delta_{V\infty}\text{-factor} \cdot V \quad (V: \text{action shear load}).$$

HVU2

Performances
Displacements

Annex C9