

European Technical Approval ETA-04/0101

English translation prepared by DIBt - Original version in German language

Handelsbezeichnung
Trade name

X-ENP-19 L15, X-ENP-19 L15 MX, X-ENP-19 L15 MXR

Zulassungsinhaber
Holder of approval

Hilti AG
Feldkircherstraße 100
9494 Schaan
FÜRSTENTUM LIECHTENSTEIN

Zulassungsgegenstand
und Verwendungszweck

Hilti Setzbolzen X-ENP-19 L15, X-ENP-19 L15 MX,
X-ENP-19 L15 MXR in Kombination mit den Hilti Setzgeräten DX 76,
DX 76 MX, DX 76 PTR, DX 860-ENP, DX 750,
DX 750 MX, DX A70 R für die Befestigung von Stahlblech an
Stahlunterkonstruktionen.

*Generic type and use
of construction product*

*Hilti powder actuated fasteners X-ENP-19 L15, X-ENP-19 L15 MX,
X-ENP-19 L15 MXR in combination with Hilti fastening tools DX 76,
DX 76 MX, DX 76 PTR, DX 860-ENP, DX 750, DX 750 MX, DX A70
R for fastening of steel sheeting to steel members.*

Geltungsdauer:
Validity:

vom
from
bis
to
to
vom
from
bis
to

10 November 2009
9 November 2014
1 March 2013
1 March 2018

verlängert
extended

Herstellwerk
Manufacturing plant

Hilti AG
Feldkircherstraße 100
9494 Schaan
FÜRSTENTUM LIECHTENSTEIN

Diese Zulassung umfasst
This Approval contains

14 Seiten einschließlich 7 Anhänge
14 pages including 7 annexes

I LEGAL BASES AND GENERAL CONDITIONS

- 1 This European technical approval is issued by Deutsches Institut für Bautechnik in accordance with:
 - Council Directive 89/106/EEC of 21 December 1988 on the approximation of laws, regulations and administrative provisions of Member States relating to construction products¹, modified by Council Directive 93/68/EEC² and Regulation (EC) N° 1882/2003 of the European Parliament and of the Council³;
 - *Gesetz über das In-Verkehr-Bringen von und den freien Warenverkehr mit Bauprodukten zur Umsetzung der Richtlinie 89/106/EWG des Rates vom 21. Dezember 1988 zur Angleichung der Rechts- und Verwaltungsvorschriften der Mitgliedstaaten über Bauprodukte und anderer Rechtsakte der Europäischen Gemeinschaften (Bauproduktengesetz - BauPG) vom 28. April 1998⁴, as amended by Article 2 of the law of 8 November 2011⁵;*
 - Common Procedural Rules for Requesting, Preparing and the Granting of European technical approvals set out in the Annex to Commission Decision 94/23/EC⁶.
- 2 Deutsches Institut für Bautechnik is authorized to check whether the provisions of this European technical approval are met. Checking may take place in the manufacturing plant. Nevertheless, the responsibility for the conformity of the products to the European technical approval and for their fitness for the intended use remains with the holder of the European technical approval.
- 3 This European technical approval is not to be transferred to manufacturers or agents of manufacturers other than those indicated on page 1, or manufacturing plants other than those indicated on page 1 of this European technical approval.
- 4 This European technical approval may be withdrawn by Deutsches Institut für Bautechnik, in particular pursuant to information by the Commission according to Article 5(1) of Council Directive 89/106/EEC.
- 5 Reproduction of this European technical approval including transmission by electronic means shall be in full. However, partial reproduction can be made with the written consent of Deutsches Institut für Bautechnik. In this case partial reproduction has to be designated as such. Texts and drawings of advertising brochures shall not contradict or misuse the European technical approval.
- 6 The European technical approval is issued by the approval body in its official language. This version corresponds fully to the version circulated within EOTA. Translations into other languages have to be designated as such.

¹ Official Journal of the European Communities L 40, 11 February 1989, p. 12
² Official Journal of the European Communities L 220, 30 August 1993, p. 1
³ Official Journal of the European Union L 284, 31 October 2003, p. 25
⁴ *Bundesgesetzblatt Teil I 1998*, p. 812
⁵ *Bundesgesetzblatt Teil I 2011*, p. 2178
⁶ Official Journal of the European Communities L 17, 20 January 1994, p. 34

II SPECIFIC CONDITIONS OF THE EUROPEAN TECHNICAL APPROVAL

1 Definition of product/ products and intended use

1.1 Definition of the construction product

The products are mechanical fasteners (powder actuated fasteners / cartridge fired pins)⁷ made of steel. The fasteners comprise a pin (nominal diameter: 4.5 mm) which is assembled with two washers. The washers serve to guide the fasteners while they are being driven into the base material. The washers also serve to improve the bearing area. Special fastening tools are used in order to install the fasteners. The driving force of the fastening tools is provided by the power load of the used cartridge (several cartridge strengths available) and can be altered at the fastening tools within a limit. The application limit depends on the strength and thickness of the base material.

The dimensions and materials of the fastener are given in Annex 1. The difference of the fastening tools is the kind of feeding: single fasteners or collated in fastener strips. Table 1 provides an overview of the 8 powder actuated fastening systems approved.

Table 1 Overview of the fastening systems

Fastener	Fastening tool	Features
X-ENP-19 L15	DX 750 DX 76 DX 76 PTR	These tools are used to drive single fasteners. ⁸
X-ENP-19 L15 MX	DX 750 MX DX 76 MX DX 76 PTR	The DX 750 MX is based on the DX 750 and the DX 76 MX is based on the DX 76. Instead of the single-fastener guide, they are equipped with fastener magazines 75/MX or MX 76. ⁹ The fasteners are collated in a MX fastener strip, which is indicated in the fastener designation.
X-ENP-19 L15 MXR	DX A70 R DX 860-ENP	The DX A70 R and DX 860-ENP are stand-up tools in which also collated fasteners are used. The fasteners are collated in a MXR fastener strip, which is indicated in the fastener designation.

Fasteners, fastening tools and cartridges are shown in Annex 1 and Annex 2.

The fastener and the corresponding connections are subject to tension and/or shear forces (see Annex 3).

1.2 Intended use

The fasteners are intended to be used for fastening of steel sheeting with steel grades \geq S280 and a thickness $t_f = 0.63$ mm - 2.5 mm (max. 4 mm for 2 - 4 layers) to steel members with steel grades \geq S235 and a thickness $t_{fl} \geq 6$ mm, provided the relevant application limits are taken into account. The sheeting can either be used as cladding or as load bearing wall and roof element.

⁷ Both terms (powder actuated fastener and cartridge fired pin) are commonly used.

⁸ In the case of the DX 76 PTR the single-fastener guide X-76-F-15-PTR has to be used.

⁹ In the case of the DX 76 PTR the fastener magazine MX 76-PTR has to be used.

For hot dip galvanized base materials a zinc coating up to approximately 150µm is allowed, for powder-coated or painted base materials a dry coat thickness of up to 160µm is allowed.

The fastener can also be used for the fastening of other thin gauge steel members.

The intended use only comprises fasteners and connections which are not directly exposed to external weather conditions or moist atmospheres.

The provisions made in this European technical approval are based on an assumed working life of the powder actuated fasteners of 25 years. The indications given on the working life cannot be interpreted as a guarantee given by the producer, but are to be regarded only as a means for choosing the right products in relation to the expected economically reasonable working life of the work.

2 Characteristics of product and methods of verification

2.1 Characteristics of product

The fastener shall correspond to the drawing given in Annex 1.

The characteristic material properties, dimensions and tolerances of the fasteners neither indicated in this section nor in Annex 1 shall correspond to the respective values laid down in the technical documentation¹⁰ to this European Technical Approval.

The characteristic and design values of the shear and tension resistance of the connections made with the fastener as well as the application limits are given in Annex 4, Annex 5 and Annex 6.

The fasteners are considered to satisfy the requirements of performance class A1 of the characteristic reaction to fire.

2.2 Methods of verification

The assessment of the fitness of the fasteners for the intended use (see Annex 1) in relation to the requirements for mechanical resistance and stability, safety in case of fire and safety in use in the sense of the Essential Requirements No. 1, No. 2 and No. 4 has been made in accordance with section 3.2 of the Common Procedural Rules for Requesting, Preparing and the Granting of European technical approvals set out in the Annex to Commission Decision 94/23/EC⁶.

Concerning Essential Requirement No. 2 (Safety in case of fire) the following applies:

The assessment of the resistance to fire performance is only relevant to the assembled system (fasteners, sheeting, substructure) which is not part of the ETA.

The fasteners are considered to satisfy the requirements of performance class A 1 of the characteristic reaction to fire, in accordance with the provisions of the EC Decision 96/603/EC (as amended) without the need for testing on the basis of its listing in that decision.

Concerning Essential Requirements No. 1 (Mechanical resistance and stability) and No. 4 (Safety in use) the following applies:

The characteristic values of resistance given in Annex 4, Annex 5 and Annex 6 were determined by tests with every fastening tool (as far as necessary).

The factor α_{cycl} given in Annex 4, Annex 5 and Annex 6 considers in accordance with EN 1993-1-3 the effect of repeated wind loads on design tension strength. The design tension strength of the fasteners is based on static

¹⁰ The technical documentation to this European Technical Approval is deposited at Deutsches Institut für Bautechnik and, as far as relevant for the tasks of the approved bodies involved in the attestation of conformity procedure is handed over to the approved bodies.

as well as on cyclic tests resulting in a factor $\alpha_{cycl} = 1.0$.

The formulas to calculate the design resistance are given in Annex 4, Annex 5 and Annex 6.

3 Evaluation and attestation of conformity and CE marking

3.1 System of attestation of conformity

According to the Decision 99/92/EC of the European Commission¹¹ system 2+ of the attestation of conformity applies.

This system of attestation of conformity is defined as follows:

System 2+: Declaration of conformity of the product by the manufacturer on the basis of:

(a) Tasks for the manufacturer:

- (1) initial type-testing of the product;
- (2) factory production control;
- (3) testing of samples taken at the factory in accordance with a prescribed test plan.

(b) Tasks for the approved body:

- (4) certification of factory production control on the basis of:
 - initial inspection of factory and of factory production control;
 - continuous surveillance, assessment and approval of factory production control.

Note: Approved bodies are also referred to as "notified bodies".

3.2 Responsibilities

3.2.1 Tasks for the manufacturer

3.2.1.1 Factory production control

The manufacturer shall exercise permanent internal control of production. All the elements, requirements and provisions adopted by the manufacturer shall be documented in a systematic manner in the form of written policies and procedures, including records of results performed. This production control system shall insure that the product is in conformity with this European technical approval.

The manufacturer may only use initial materials stated in the technical documentation of this European technical approval.

The factory production control shall be in accordance with the control plan relating to this European technical approval which is part of the technical documentation of this European technical approval. The control plan is laid down in the context of the factory production control system operated by the manufacturer and deposited with Deutsches Institut für Bautechnik.¹²

The results of factory production control shall be recorded and evaluated in accordance with the provisions of the control plan.

¹¹ Official Journal of the European Communities L 80 of 18.03.1998

¹² The "control plan" is a confidential part of the European technical approval and only handed over to the approved bodies involved in the procedure of attestation of conformity. See section 3.2.2.

3.2.1.2 Other tasks for the manufacturer

The manufacturer shall, on the basis of a contract, involve a body which is approved for the tasks referred to in section 3.1 in the field of powder actuated fasteners in order to undertake the actions laid down in section 3.2.2 For this purpose, the control plan referred to in sections 3.2.1.1 and 3.2.2 shall be handed over by the manufacturer to the approved body involved.

The manufacturer shall make a declaration of conformity, stating that the construction product is in conformity with the provisions of this European technical approval.

3.2.2 Tasks for the approved bodies

The approved body shall perform the

- initial inspection of factory and of factory production control,
- continuous surveillance, assessment and approval of factory production control

in accordance with the provisions laid down in the control plan.

The approved body shall retain the essential points of its actions referred to above and state the results obtained and conclusions drawn in written reports.

The approved certification body involved by the manufacturer shall issue an EC certificate of conformity of the factory production control stating the conformity with the provisions of this European technical approval.

In cases where the provisions of the European technical approval and its control plan are no longer fulfilled the certification body shall withdraw the certificate of conformity and inform Deutsches Institut für Bautechnik without delay.

3.3 CE marking

The CE marking shall be affixed on each packaging of fasteners. The letters "CE" shall be followed by the identification number of the approved certification body, where relevant, and be accompanied by the following additional information:

- the name and address of the producer (legal entity responsible for the manufacture),
- the last two digits of the year in which the CE marking was affixed,
- the number of the EC certificate for the factory production control,
- the number of the European technical approval,
- the name of the product

4 Assumptions under which the fitness of the product for the intended use was favourably assessed

4.1 Manufacturing

The fasteners are manufactured in accordance with the provisions of the European Technical Approval using the manufacturing process as laid down in the technical documentation.

The European technical approval is issued for the product on the basis of agreed data/information, deposited with Deutsches Institut für Bautechnik, which identifies the product that has been assessed and judged. Changes to the product or production process, which could result in this deposited data/information being incorrect, should be notified to Deutsches Institut für Bautechnik before the changes are introduced. Deutsches Institut für Bautechnik will decide whether or not such changes affect the approval and consequently the validity of the CE marking on the basis of the approval and if so whether further assessment or alterations to the approval shall be necessary.

4.2 Design

For the types of connection (a, b, c, d) listed in Annex 4, Annex 5 and Annex 6 it is not necessary to take into account the effect of constraints due to temperature for the steel grades S280 and S320 in accordance with EN 10346:2009. For the steel grade S350 in accordance with EN 10346:2009 it shall be considered for design.

The loading is predominantly static. (Remark: Wind loads are regarded as predominantly static.) Dimensions, material properties, application limits and nail head standoff as stated in the ETA are observed.

The verification concept stated in EN 1990:2002 + A1:2005 + A1:2005/AC:2010 is used for the design of the connections made with the fasteners. The characteristic values (shear and tension resistance) stated in Annex 4, Annex 5 and Annex 6 are used for the design of the entire connections.

The partial safety factor $\gamma_M = 1.25$ is used in order to determine the corresponding design resistances, provided no values are given in national regulations of the member state in which the fastener is used or in the respective National Annex to Eurocode 3.

In case of combined tension and shear forces the linear interaction formula according to EN 1993-1-3:2006 + AC:2009, section 8.3 (8) is taken into account.

The possibly required reduction of the tension resistance due to the position of the fastener is taken into account in accordance with EN 1993-1-3:2006 + AC:2009, section 8.3 (7) and Fig. 8.2.

4.3 Installation

The installation is carried out such that the fasteners are replaceable if necessary.

The installation is only carried out according to the manufacturer's instructions (see Annex 7). The steel sheeting is in direct contact with the steel supporting structure in the area of the connections. The manufacturer hands over the assembly instructions to the assembler.

Cartridge selection and tool energy settings in order to cover the application limit diagram are taken into account as given in Annex 4, Annex 5 and Annex 6.

Installation safety tests are to be carried out (e.g. check of nail head standoff), provided the fitness of the recommended cartridge cannot be checked otherwise.

The nail head standoff (NHS) is in accordance with the requirements given in Annex 4, Annex 5 and Annex 6.

The conformity of the installed fastener with the provisions of the ETA is attested by the executing company.

5 Indications to the manufacturer

It is in the responsibility of the manufacturer to ensure that the information on the specific conditions according to 1, 2, 4.2 and 4.3 (including Annexes referred to) is given to those who are concerned. This information may be given by reproduction of the respective parts of the European Technical Approval. In addition all installation data (minimum / maximum nail head standoff, application limits in accordance with Annex 4, Annex 5 and Annex 6) shall be shown clearly on the package and/or on an enclosed instruction sheet, preferably using illustration(s).

Georg Feistel
Head of Department

beglaubigt:
Ulbrich

Powder-actuated fastener / Cartridge fired pin

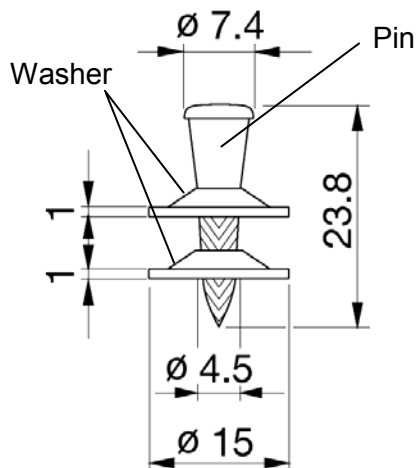

Material:

Pin Steel Ck67 tempered, quenched and galvanised

Washer Steel DC01 galvanised

Zinc coating to resist 2 cycles Kesternich test with 2 l SO₂ according to EN 3231 without red rust

Example of powder-actuated fastening tool and cartridge



Detail of wheel on tool allowing continuous regulation of the driving energy within one cartridge colour:
Setting 1: Minimum energy
Setting 4: Maximum energy



Example of intended use / application



Cartridges 6,8/18 M(40):

- Blue: Medium load (level 5)
- Red: Medium high load (level 6)
- Black: Extra high load (level 7)

X-ENP-19 L15, X-ENP-19 L15 MX, X-ENP-19 L15 MXR

Fastener, fastening tool, cartridge, example of intended use / application

Annex 1

<p>Single Fastener: X-ENP-19 L15</p>		
 <p>DX 750</p>	 <p>DX 76</p>	 <p>DX 76 PTR with single-fastener guide X-76-F-15-PTR</p>
<p>Collated fasteners for magazine tools: X-ENP-19 L15 MX</p>		
 <p>DX 750 MX</p>	 <p>DX 76 MX</p>	 <p>DX 76 PTR with magazine MX 76-PTR</p>
<p>Collated fasteners for stand-up tools: X-ENP-19 L15 MXR</p>		
 <p>DX A70 R</p>	 <p>DX 860-ENP</p>	
<p>X-ENP-19 L15, X-ENP-19 L15 MX, X-ENP-19 L15 MXR</p>		<p>Annex 2</p>
<p>Fastener and corresponding fastening tools</p>		<p>Annex 2</p>

Types of connection and corresponding loading conditions

	Types of connection			
	Type a	Type b	Type c	Type d
Type of loading	Single connection	Side lap connection	End overlap connection	Side lap + end overlap connection
Shear loading				
Tension loading				

X-ENP-19 L15, X-ENP-19 L15 MX, X-ENP-19 L15 MXR

Types of connection

Annex 3

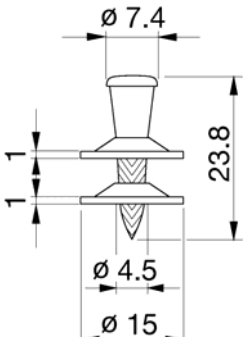
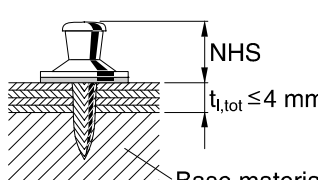
	<p>Powder-actuated fastener and fastening tool: X-ENP-19 L15 with DX 76 X-ENP-19 L15 MX with DX 76 MX X-ENP-19 L15 MXR with DX 860-ENP</p> <p>Piston: X-76-P-ENP</p> <p>Cartridges: 6.8 / 18M (DX 76, DX 76 MX) 6.8 / 18M40 (DX 860-ENP)</p>	<p>Installation control:</p>  <p>NHS = 8.2 bis 9.8 mm A piston mark on the top washer is clearly visible.</p>
---	--	--

Characteristic shear and tension resistance V_{RK} and N_{RK}				Design shear and tension resistance V_{Rd} and N_{Rd}	
sheeting thickness t_i [mm]	Shear V_{RK} [kN]	Tension N_{RK} [kN]	Types of connection	$V_{Rd} = V_{RK} / \gamma_M$ $\gamma_M = 1.25$ in the absence of national regulations	$N_{Rd} = \alpha_{cycl} N_{RK} / \gamma_M$ α_{cycl} considers the effect of repeated wind loads $\alpha_{cycl} = 1.0$ for all sheeting thickness t_i $\gamma_M = 1.25$ in the absence of national regulations
0.63	4.0	4.1	a,b,c,d		
0.75	4.7	6.3	a,b,c,d		
0.88	5.4	7.2	a,b,c,d		
1.00	6.0	8.0	a,b,c,d		
1.13	7.0	8.4	a,c		
1.25	8.0	8.8	a,c		
1.50	8.6	8.8	a		
1.75	8.6	8.8	a		
2.00	8.6	8.8	a		
2.50	8.6	8.8	a		

Application limit diagram

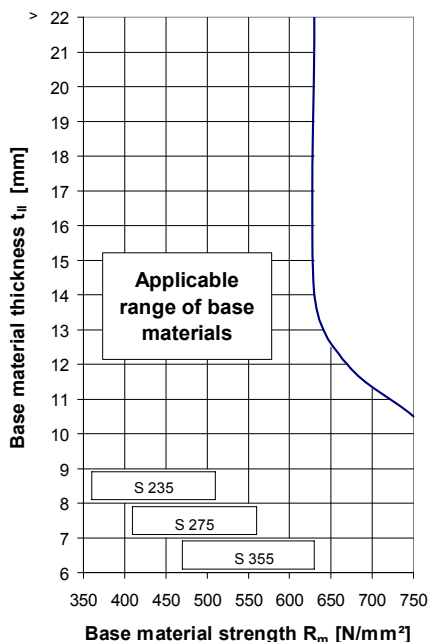

Base material:
Structural steel S235, S275 and S355 in qualities JR, JO, J2, K2 according to EN 10025-2; minimum thickness = 6 mm

Cartridge selection and tool energy setting

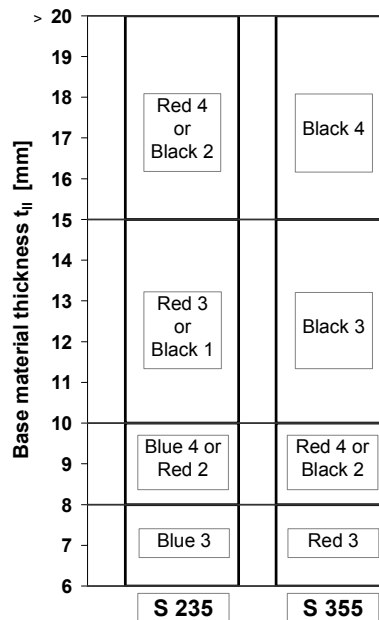

Note for S 275: Start with recommendation for S 355.
In case of too much energy: Reduction of tool energy setting or change of cartridge colour til correct stand-offs NHS are achieved.

X-ENP-19 L15, X-ENP-19 L15 MX, X-ENP-19 L15 MXR

X-ENP-19 L15 with tools DX 76, DX 76 MX and DX 860-ENP:
Characteristic and design resistance, application limit, cartridge selection and nail head standoff

Annex 4

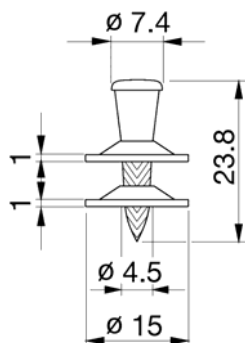

Powder-actuated fastener and fastening tool:
X-ENP-19 L15 with DX 750
X-ENP-19 L15 MX with DX 750 MX
X-ENP-19 L15 MXR with DX A70 R

Piston: **75 / ENP2-L**

Cartridges: **6.8 / 18M (DX 750, DX 750 MX)**
6.8 / 18M40 (DX A70 R)

Installation control:

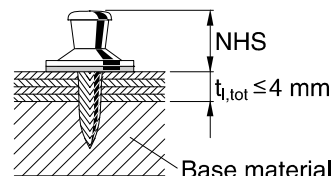

NHS = 8.2 bis 9.8 mm

A piston mark on the top washer is clearly visible.

Characteristic shear and tension resistance V_{RK} and N_{RK}

Design shear and tension resistance V_{Rd} and N_{Rd}

sheeting thickness t_i [mm]	Shear V_{RK} [kN]	Tension N_{RK} [kN]	Types of connection
0.63	4.0	4.1	a,b,c,d
0.75	4.7	6.3	a,b,c,d
0.88	5.4	7.2	a,b,c,d
1.00	6.0	8.0	a,b,c,d
1.13	7.0	8.4	a,c
1.25	8.0	8.8	a,c
1.50	8.6	8.8	a
1.75	8.6	8.8	a
2.00	8.6	8.8	a
2.50	8.6	8.8	a

$V_{Rd} = V_{RK} / \gamma_M$ $\gamma_M = 1.25$ in the absence of national regulations	$N_{Rd} = \alpha_{cycl} N_{RK} / \gamma_M$ α_{cycl} considers the effect of repeated wind loads $\alpha_{cycl} = 1.0$ for all sheeting thickness t_i $\gamma_M = 1.25$ in the absence of national regulations
--	---

Application limit diagram

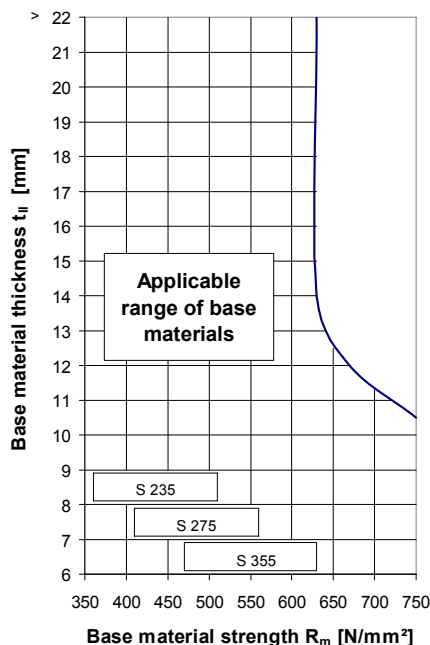

Base material:
Structural steel S235, S275 and S355 in qualities JR, JO, J2, K2 according to EN 10025-2; minimum thickness = 6 mm

Cartridge selection and tool energy setting

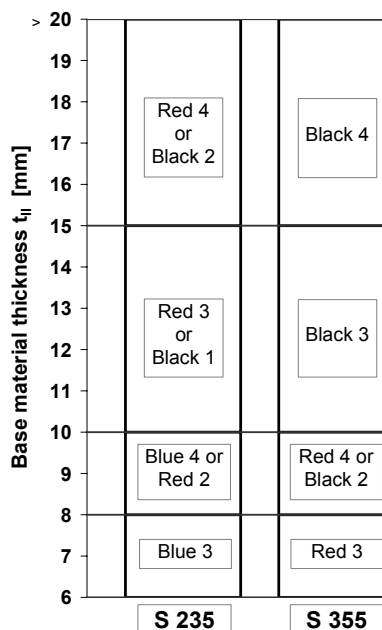

Note for S 275: Start with recommendation for S 355.
In case of too much energy: Reduction of tool energy setting or change of cartridge colour til correct stand-offs NHS are achieved.

X-ENP-19 L15, X-ENP-19 L15 MX, X-ENP-19 L15 MXR

X-ENP-19 L15 with tools DX 750, DX 750 MX and DX A70 R:
Characteristic and design resistance, application limit, cartridge selection and nail head standoff

Annex 5

English translation prepared by DIBt

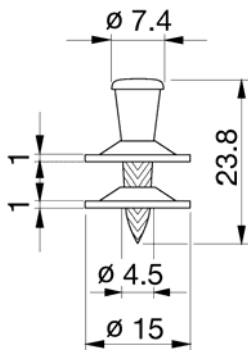

Powder-actuated fastener and fastening tool:

X-ENP-19 L15 with DX 76 PTR and single-fastener guide X-76-F-15-PTR

X-ENP-19 L15 MX with DX 76 PTR and fastener magazine MX 76-PTR

Piston: **X-76-P-ENP-PTR**

Cartridges: **6.8 / 18M**

Installation control:

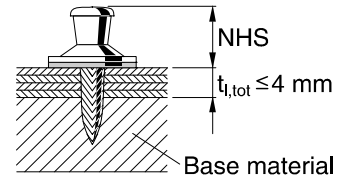

NHS = 8.2 bis 9.8 mm

A piston mark on the top washer is clearly visible.

Characteristic shear and tension resistance V_{Rk} and N_{Rk}

sheeting thickness t_i [mm]	Shear V_{Rk} [kN]	Tension N_{Rk} [kN]	Types of connection
0.75	4.7	6.3	a,b,c,d
0.88	5.4	7.2	a,b,c,d
1.00	6.0	8.0	a,b,c,d
1.13	7.0	8.4	a,c
1.25	8.0	8.8	a,c
1.50	8.6	8.8	a
1.75	8.6	8.8	a
2.00	8.6	8.8	a
2.50	8.6	8.8	a

Design shear and tension resistance V_{Rd} and N_{Rd}

$V_{Rd} = V_{Rk} / \gamma_M$	$N_{Rd} = \alpha_{cycl} N_{Rk} / \gamma_M$
$\gamma_M = 1.25$ in the absence of national regulations	α_{cycl} considers the effect of repeated wind loads $\alpha_{cycl} = 1.0$ for all sheeting thickness t_i $\gamma_M = 1.25$ in the absence of national regulations

Application limit diagram

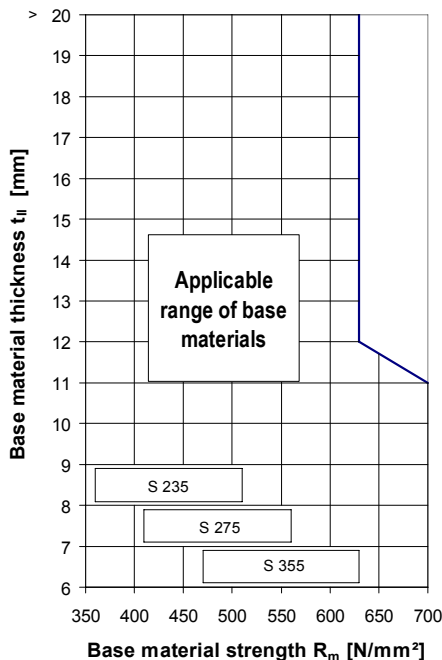

Base material:
Structural steel S235, S275 and S355 in qualities JR, JO, J2, K2 according to EN 10025-2; minimum thickness = 6 mm

Cartridge selection and tool energy setting

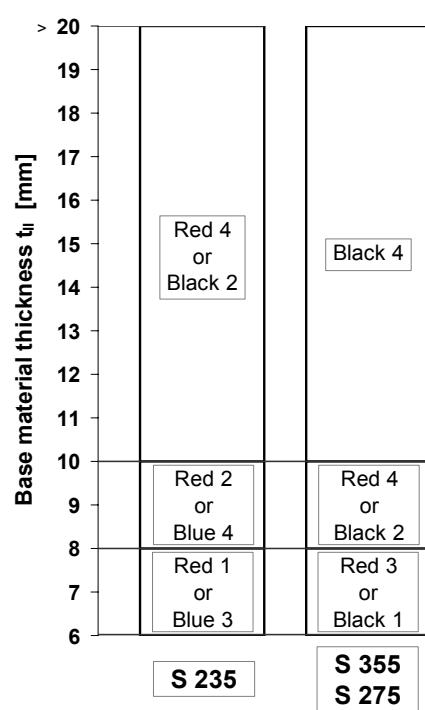

X-ENP-19 L15, X-ENP-19 L15 MX, X-ENP-19 L15 MXR

X-ENP-19 L15 with tool DX 76 PTR:
Characteristic and design resistance, application limit, cartridge selection and nail head standoff

Annex 6

Instructions for use

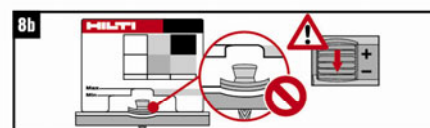
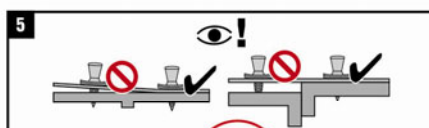
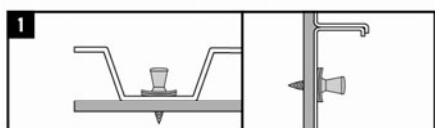
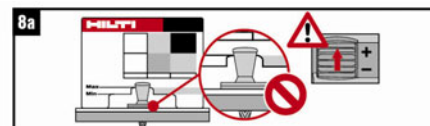
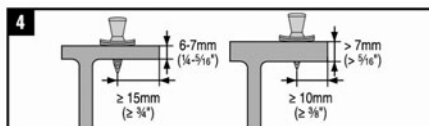
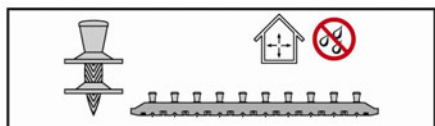

X-ENP-19 L15 MXR	DX 860-ENP DX 76 PTR	6.8 / 18 M40
X-ENP-19 L15 MX	DX 76 MX DX 750 MX	6.8 / 18 M10
X-ENP-19 L15	DX 76 F15 DX 750	

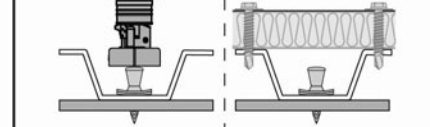
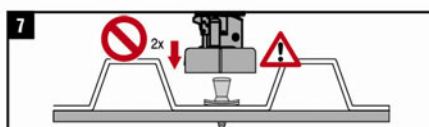
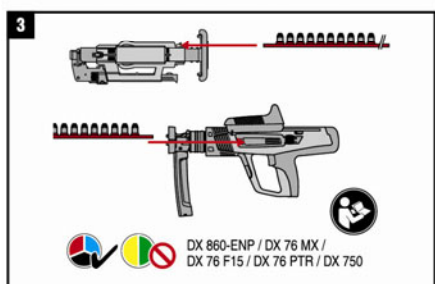
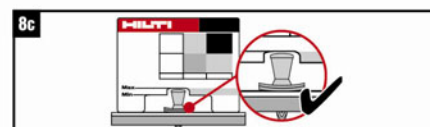
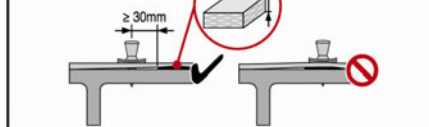

X-ENP-19 L15, X-ENP-19 L15 MX, X-ENP-19 L15 MXR

Instructions for use

Annex 7