



ETA-Danmark A/S  
Göteborg Plads 1  
DK-2150 Nordhavn  
Tel. +45 72 24 59 00  
Internet [www.etadanmark.dk](http://www.etadanmark.dk)

Authorised and notified  
according to Article 29 of the  
Regulation (EU)  
No 305/2011 of the European  
Parliament and of the Council  
of 9 March 2011

MEMBER OF EOTA



## European Technical Assessment ETA-21/0084 of 2022/03/04

### I General Part

**Technical Assessment Body issuing the ETA and designated according to Article 29 of the Regulation (EU) No 305/2011: ETA-Danmark A/S**

**Trade name of the construction product:**

ACR 240

**Product family to which the above construction product belongs:**

Fire Stopping and Sealing Product:  
• Linear Joint and Gap Seals

**Manufacturer:**

Würth International AG  
Aspermontstrasse 1  
CH- 7000 Chur  
Switzerland

**Manufacturing plant:**

A/003

**This European Technical Assessment contains:**

16 pages including 1 annex which form an integral part of the document

**This European Technical Assessment is issued in accordance with Regulation (EU) No**

EAD 350141-00-1106

**This version replaces:**

-

**Translations of this European Technical Assessment in other languages shall fully correspond to the original issued document and should be identified as such.**

**Communication of this European Technical Assessment, including transmission by electronic means, shall be in full. However, partial reproduction may be made, with the written consent of the issuing Technical Assessment Body. Any partial reproduction has to be identified as such.**

**Table of Contents**

<b>I.</b>	<b>SPECIFIC PARTS OF THE EUROPEAN TECHNICAL ASSESSMENT</b>	<b>4</b>
1	Technical description of the product	4
2	Specification of the intended uses of the product in accordance with the applicable European Assessment Document (Hereinafter EAD): EAD 350141-00-1106, September 2017	5
3	Performance of the product and references to the methods used for its assessment	6
4	ASSESSMENT AND VERIFICATION OF CONSTANCY OF PERFORMANCE (HEREINAFTER AVCP) SYSTEM APPLIED, WITH REFERENCE TO ITS LEGAL BASE	7
5	Technical details necessary for the implementation of the AVCP system, as provided for in the applicable EAD	7
	<b>ANNEX A – Resistance to Fire Classification – ACR 240</b>	<b>8</b>
A.1	Flexible wall constructions according to 2.1) with wall thickness of minimum 75 mm and minimum 1 x layer of 12.5 mm board per side	8
A.1.1	Linear joint seals, between head of flexible wall and soffit of concrete floor and vertical end of flexible wall and concrete wall	8
A.2	Flexible wall constructions according to 1.2.1 with wall thickness of minimum 100 mm and minimum 2 x layer of 12.5 mm board per side	9
A.2.1	Linear joint seals, between head of flexible wall and soffit of concrete floor and vertical end of flexible wall and concrete wall	9
A.2.2	Flexible wall construction with wall thickness of minimum 100 mm and timber substrates and architraves	10
A.2.2.1	Linear joint or gap seals, vertically or horizontal orientated with backing materials	10
A.2.3	Flexible wall construction with wall thickness of minimum 100 mm and timber substrates	11
A.2.3.1	Linear joint or gap seals, vertically or horizontal orientated with backing materials	11
A.2.4	Flexible wall construction with wall thickness of minimum 100 mm and steel substrates	12
A.2.4.1	Linear joint or gap seals, vertically or horizontal orientated with backing materials	12
A.2.5	Linear joint or gap seals, vertically or horizontal orientated with backing materials	13
A.3	Rigid wall constructions according to 1.2.1 with wall thickness of minimum 150 mm	14
A.3.1	Linear joint or gap seal, between head of rigid wall and soffit of concrete floor / between rigid walls	14
A.4	Rigid floor constructions according to 1.2.1 with floor thickness of minimum 150 mm	15
A.4.1	Linear joint or gap seal, between floor slabs or between floor slab and wall with sealant to the top face of the floor only	15
A.4.2	Linear joint or gap seals, in or between rigid floors	16

**I. SPECIFIC PARTS OF THE EUROPEAN TECHNICAL ASSESSMENT**

**1 Technical description of the product**

- 1) ACR 240 is an intumescent acrylic sealant used to form linear gap seals where gaps are present in wall and floor constructions and linear joint seals where wall and floor constructions abut.
- 2) The ACR 240 is supplied in liquid form contained within 310 & 380 ml cartridges and 600 ml foil packs. The sealant is gunned into the aperture in the separating element/elements and around the service or services, to a specified depth utilising a backing material.
- 3) ACR 240 contains no carcinogenic substances or mutagenic substances, flame retardants or antimicrobiological agents.
- 4) The applicant has submitted a written declaration that ACR 240 does not contain substances which have to be classified as dangerous according to Directive 67/548/EEC and Regulation (EC) No 1272/2008 and listed in the "Indicative list on dangerous substances" of the EGDS - taking into account the installation conditions of the construction product and the release scenarios resulting from there.

In addition to the specific clauses relating to dangerous substances contained in this European technical Assessment, there may be other requirements applicable to the products falling within its scope (e.g. transposed European legislation and national laws, regulations and administrative provisions). In order to meet the provisions of the Construction Products Regulation, these requirements need also to be complied with, when and where they apply.

- 5) The use category of ACR 240 in relation to BWR 3 (Hygiene, health and environment) is IA1.

**2 Specification of the intended uses of the product in accordance with the applicable European Assessment Document (Hereinafter EAD): EAD 350141-00-1106**

Detailed information and data is given in Annex A.

The intended use of system ACR 240 is to reinstate the fire resistance performance of gaps in and joints in and between flexible wall and rigid wall constructions, gaps in and joints between rigid floor constructions.

- 1) The specific elements of construction that the system ACR 240 may be used to provide a gap or joint seal in, are as follows:

Flexible walls: The wall must have a minimum thickness of 75 mm and comprise steel or wooden studs lined on both faces with minimum 1 layers of 12.5 mm thick boards. The wall is permitted with or without insulation material between the boards.

Rigid walls: The wall must have a minimum thickness of 75 mm and comprise concrete, aerated concrete or masonry, with a minimum density of 650 kg/m<sup>3</sup>.

Rigid floors: The floor must have a minimum thickness of 150 mm and comprise aerated concrete or concrete with a minimum density of 650 kg/m<sup>3</sup>.

The supporting construction must be classified in accordance with EN 13501-2 for the required fire resistance period.

- 2) The system ACR 240 may be used to provide a linear joint or gap seal with specific supporting constructions and substrates (for details see Annex A).

Würth Fire Protection Systems which involve linear seals on both sides of a flexible wall may also be used in the situation where the linear seal is on one side of the wall only and the remaining side of the wall is not punctured at the same point. All fire integrity and thermal insulation ratings for such single-sided linear seals remain the same as for the equivalent double-sided linear seal.

- 3) The maximum permitted joint/gap width for system ACR 240 is 100 mm.
- 4) The maximum movement capability of system ACR 240 is  $\leq 7.5\%$  (not tested to EAD 350141-00-1106).
- 5) The provisions made in this European Technical Assessment are based on an assumed working life of the ACR 240 of 30 years, provided that the conditions laid down in sections 4.2/5.1/5.2 for the packaging/transport/ storage/installation/use/repair are met. The indications given on the working life cannot be interpreted as a guarantee given by the producer or the Technical Assessment Body but are to be regarded only as a means for choosing the right products in relation to the expected economically reasonable working life of the works.
- 6) Type Z<sub>2</sub>: Intended for uses in internal conditions with humidity lower than 85 % RH excluding temperatures below 0°C, without exposure to rain or UV.

**3 Performance of the product and references to the methods used for its assessment**

Product-type: Sealant	Intended use: Linear Joint & Gap Seal
Essential characteristic	Performance
<b>BWR 2 Safety in case of fire</b>	
Reaction to fire	Class D-s1, d1
Resistance to fire	Annex A
<b>BWR 3 Hygiene, health and environment</b>	
Content, emission and/or release of dangerous substances	Use categories: IA1 Declaration of manufacturer
Air permeability (material property)	No performance assessed
Water permeability (material property)	No performance assessed
<b>BWR 4 Safety in use</b>	
Mechanical resistance and stability	No performance assessed
Resistance to impact/movement	No performance assessed
Adhesion	No performance assessed
Durability	Z <sub>2</sub>
Movement capacity	No performance assessed
Cycling of perimeter seals for curtain walls	No performance assessed
Compression set	No performance assessed
Linear expansion on setting	No performance assessed
<b>BWR 5 Protection against noise</b>	
Airborne sound insulation	R <sub>w</sub> (C;Ctr)= 62 (-1;-5) dB*
<b>BWR 6 Energy economy and heat retention</b>	
Thermal properties	No performance assessed
Water vapour permeability	No performance assessed

\* At 12 mm depth

**4 ASSESSMENT AND VERIFICATION OF CONSTANCY OF PERFORMANCE (HEREINAFTER AVCP) SYSTEM APPLIED, WITH REFERENCE TO ITS LEGAL BASE**

According to the decision 1999/454/EC – Commission Decision of date 22nd June 1999 on the procedure for attesting the conformity of construction products pursuant to Article 20(2) of Council Directive 89/106/EEC as regards fire stopping, fire sealing and fire protective products, published in the Official Journal of the European Union (OJEU) L178/52 of 14/07/1999, see <http://eur-lex.europa.eu/JOIndex.do> of the European Commission<sup>1</sup>, as amended, the system(s) of assessment and verification of constancy of performance (see Annex V to Regulation (EU) No 305/2011) given in the following table(s) applies (apply).

Product(s)	Intended use(s)	Level(s) or class(es)	System(s)
Fire stopping and Fire Sealing Products	For fire compartmentation and/or fire protection or fire performance	Any	1

**5 Technical details necessary for the implementation of the AVCP system, as provided for in the applicable EAD**

Technical details necessary for the implementation of the AVCP system are laid down in the control plan deposited at ETA-Danmark A/S prior to CE marking

Issued in Copenhagen on 2022-03-04 by



Thomas Bruun

Managing Director, ETA-Danmark

---

<sup>1</sup> Official Journal of the European Communities L178/52 of 14/7/1999

## ANNEX A – Resistance to Fire Classification – ACR 240

**A.1 Flexible wall constructions according to 2 1) with wall thickness of minimum 75 mm and minimum 1 x layer of 12.5 mm board per side**

**A.1.1 Linear joint seals, between head of flexible wall and soffit of concrete floor and vertical end of flexible wall and concrete wall**

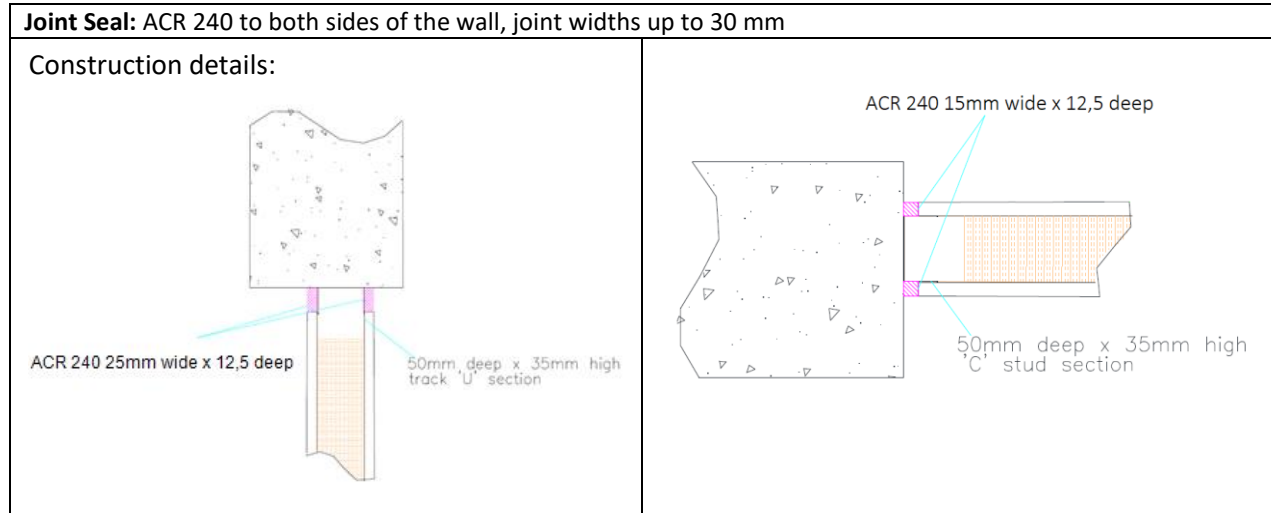

### A.1.1.1

Substrate	Depth (mm)	Backing (minimum)	Classification
Plasterboard / concrete	12.5 min.	50 mm steel partition head track/ stud	E 60 – T – X – F – W 25 EI 45 – T – X – F – W 25
			E 60 – V – X – F – W 15 EI 45 – V – X – F – W 15



**A.2 Flexible wall constructions according to 1.2.1 with wall thickness of minimum 100 mm and minimum 2 x layer of 12.5 mm board per side**

**A.2.1 Linear joint seals, between head of flexible wall and soffit of concrete floor and vertical end of flexible wall and concrete wall**

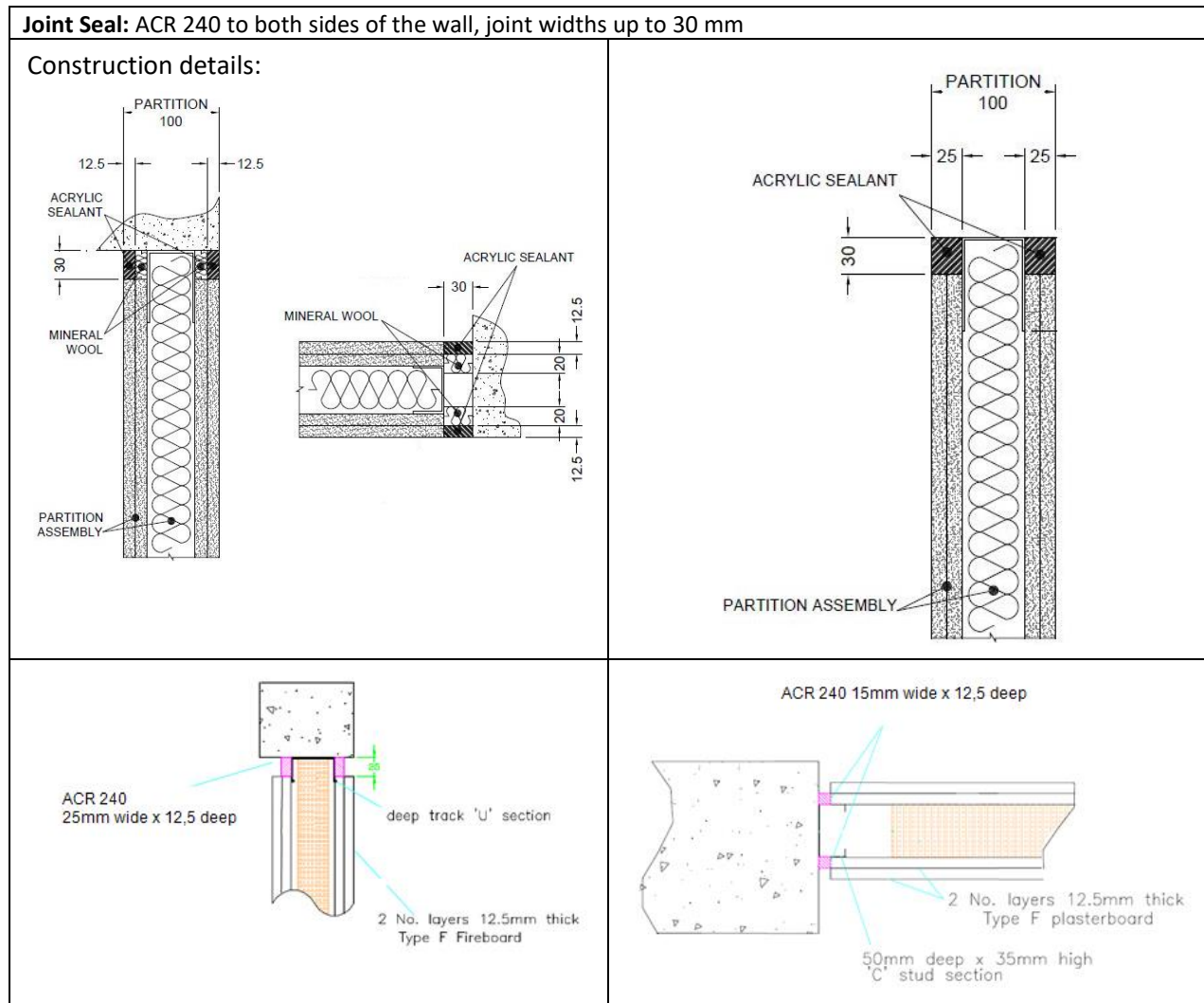

**A.2.1.1**

Substrate	Depth (mm)	Backing (minimum)	Classification
Plasterboard / concrete	12.5 min.	12.5 mm Stone wool 35 kg/m <sup>3</sup> plus 50 mm steel partition head track	<b>EI 120 – T – X – F – W 30</b>
		20 mm Stone wool 35 kg/m <sup>3</sup>	<b>EI 120 – V – X – F – W 30</b>
	25 min.	50 mm steel partition head track	<b>EI 120 – T – X – F – W 30</b>
	12.5 min.	/stud	<b>EI 90 – T – X – F – W 25</b>

## A.2.2 Flexible or rigid wall construction with wall thickness of minimum 100 mm and timber substrates and architraves

### A.2.2.1 Linear joint or gap seals, vertically or horizontal orientated with backing materials

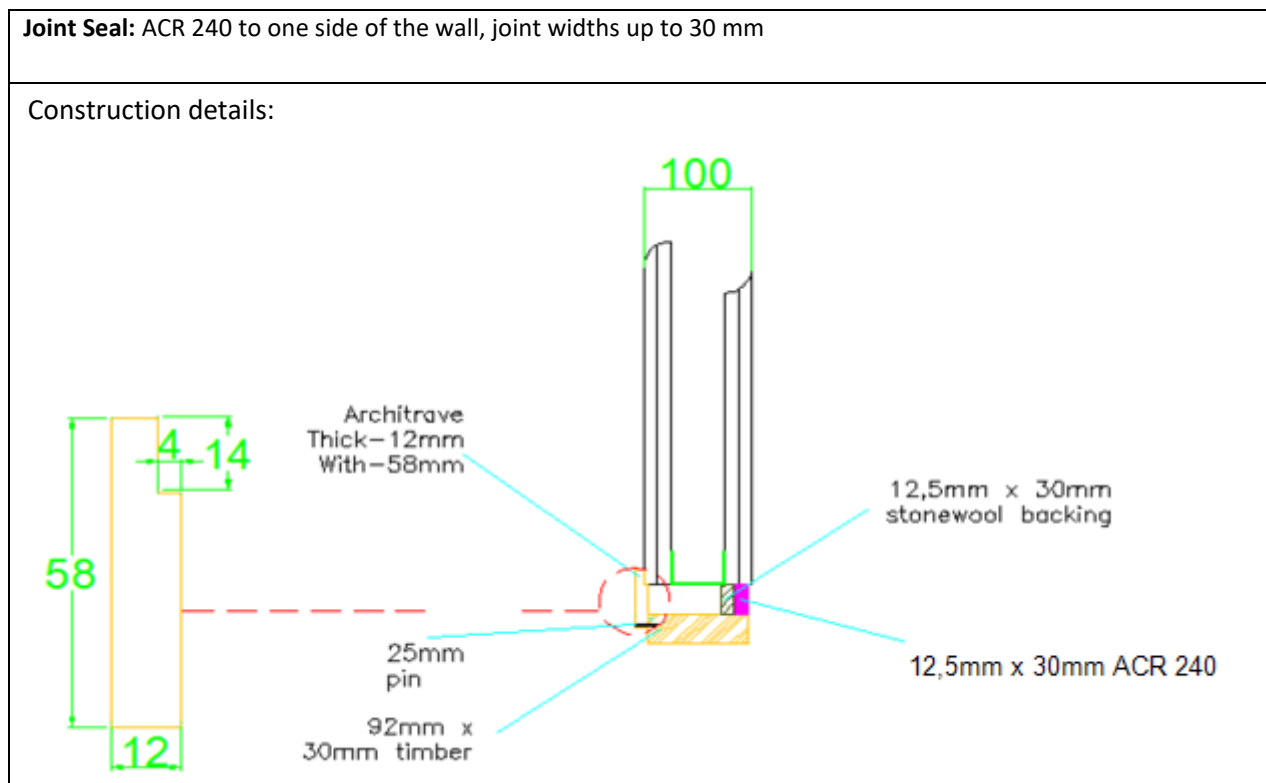

### A.2.2.2

Substrate	Depth (mm)	Facing (minimum)	Backing	Classification
Flexible or rigid wall / Timber	12.5 min.	Single sided linear seals in flexible or rigid walls against wooden frames covered with architraves on the other side fixed with 25 mm steel pins at nominal 300 mm centres.	Stonewool, 12.5mm deep min. 35 kg/m <sup>3</sup>	EI 60 – V – X – F – W 30
				EI 60 – T – X – F – W 30

**A.2.3 Flexible or rigid wall construction with wall thickness of minimum 100 mm and timber substrates**

**A.2.3.1 Linear joint or gap seals, vertically or horizontal orientated with backing materials**

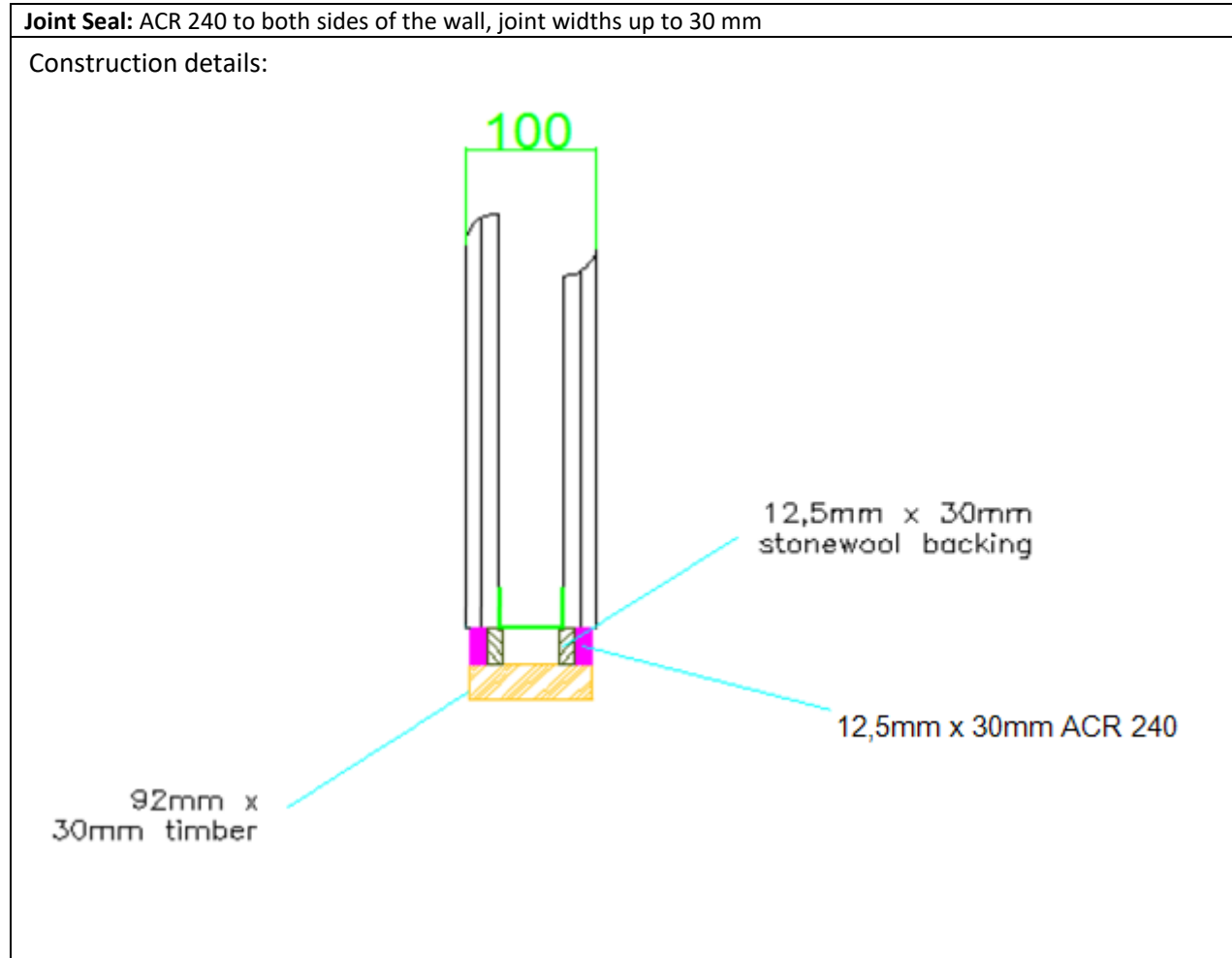

**A.2.3.2**

Substrate	Depth (mm)	Backing	Classification
Flexible or rigid wall / Timber	12.5 min.	Stonewool, 12.5 mm deep min. 35 kg/m <sup>3</sup>	E 90 – V – X – F – W 30
			EI 60 – V – X – F – W 30
			E 90 – T – X – F – W 30
			EI 60 – T – X – F – W 30

**A.2.4 Flexible or rigid wall construction with wall thickness of minimum 100 mm and steel substrates**

**A.2.4.1 Linear joint or gap seals, vertically or horizontal orientated with backing materials**

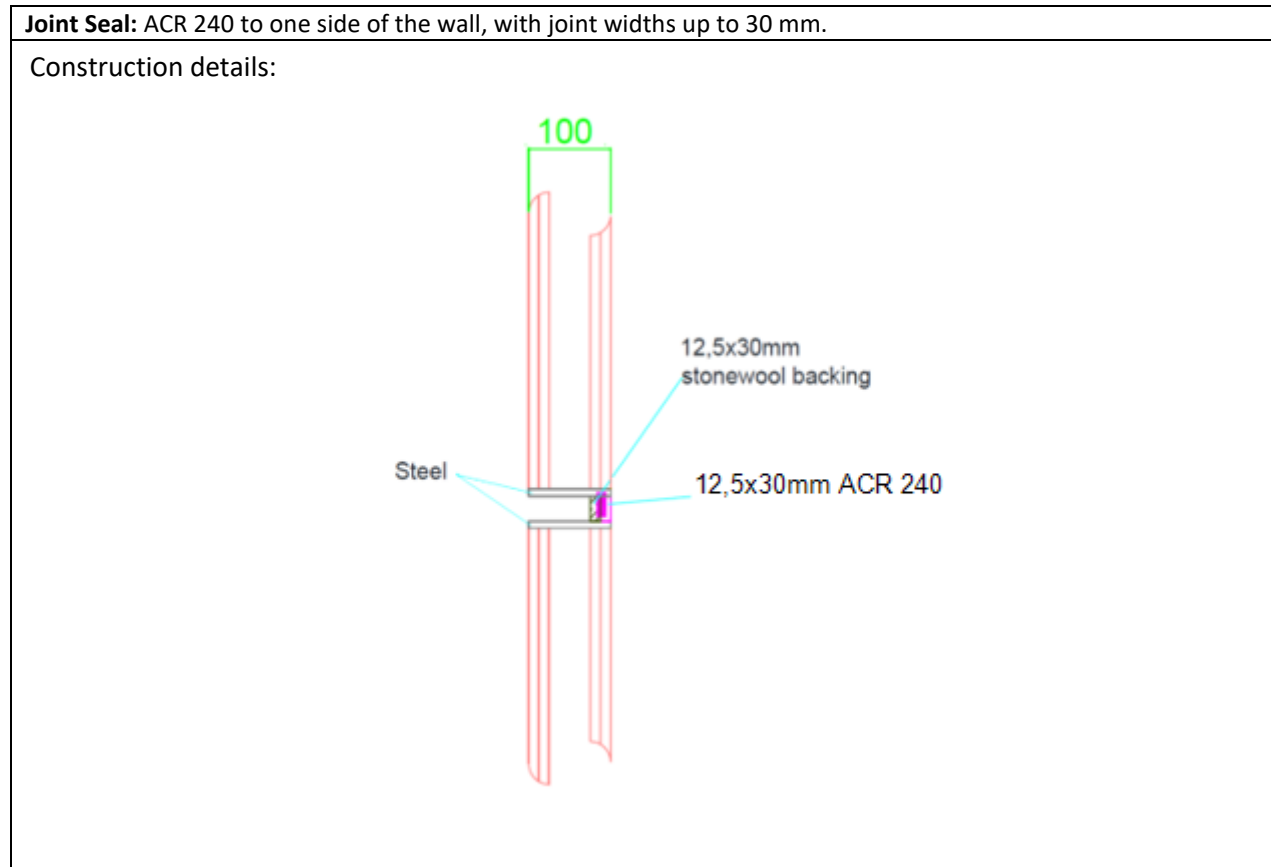

**A.2.4.2**

Substrate	Depth (mm)	Backing	Classification
Steel / steel	12.5 min.	Stonewool, 12.5 mm deep min. 35 kg/m <sup>3</sup>	E 120 – V – X – F – W 30
			EI 30 – V – X – F – W 30
Steel / steel	12.5 min.	Stonewool, 12.5 mm deep min. 35 kg/m <sup>3</sup>	E 120 – T – X – F – W 30
			EI 30 – T – X – F – W 30

### A.2.5 Linear joint or gap seals, vertically or horizontal orientated with backing materials

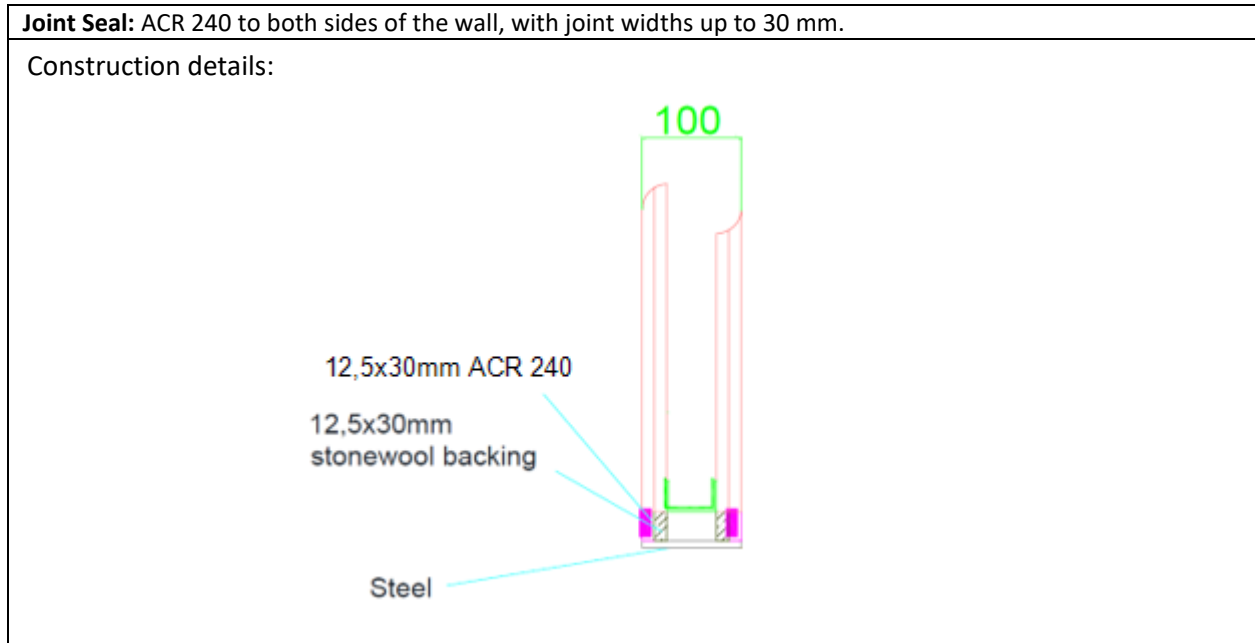

#### A.2.5.1

Substrate	Depth (mm)	Backing	Classification
Flexible or rigid wall / Steel	12.5 min.	Stonewool, 12.5 mm deep min. 35 kg/m <sup>3</sup>	E 120 – V – X – F – W 30 <sup>1</sup> EI 30 – V – X – F – W 30 <sup>2</sup>
			E 120 – T – X – F – W 30 <sup>3</sup> EI 45 – T – X – F – W 30 <sup>4</sup>

\*Additional and for information only.

The classifications provided in Table A.2.5.1 consider the insulation performance of all components within the firestopping system as per the requirements of EN 1366-4. This includes temperature evaluation of the steel substrate.

In relation to each of the above classifications, temperatures recorded on the seal (exclusive of the supporting construction) exceeded the maximum allowable after the following times (rounded down):

<sup>1</sup> 120, <sup>2</sup> 90, <sup>3</sup> 120, <sup>4</sup> 60

**A.3 Rigid wall constructions according to 1.2.1 with wall thickness of minimum 150 mm**

**A.3.1 Linear joint or gap seal, between head of rigid wall and soffit of concrete floor / between rigid walls**

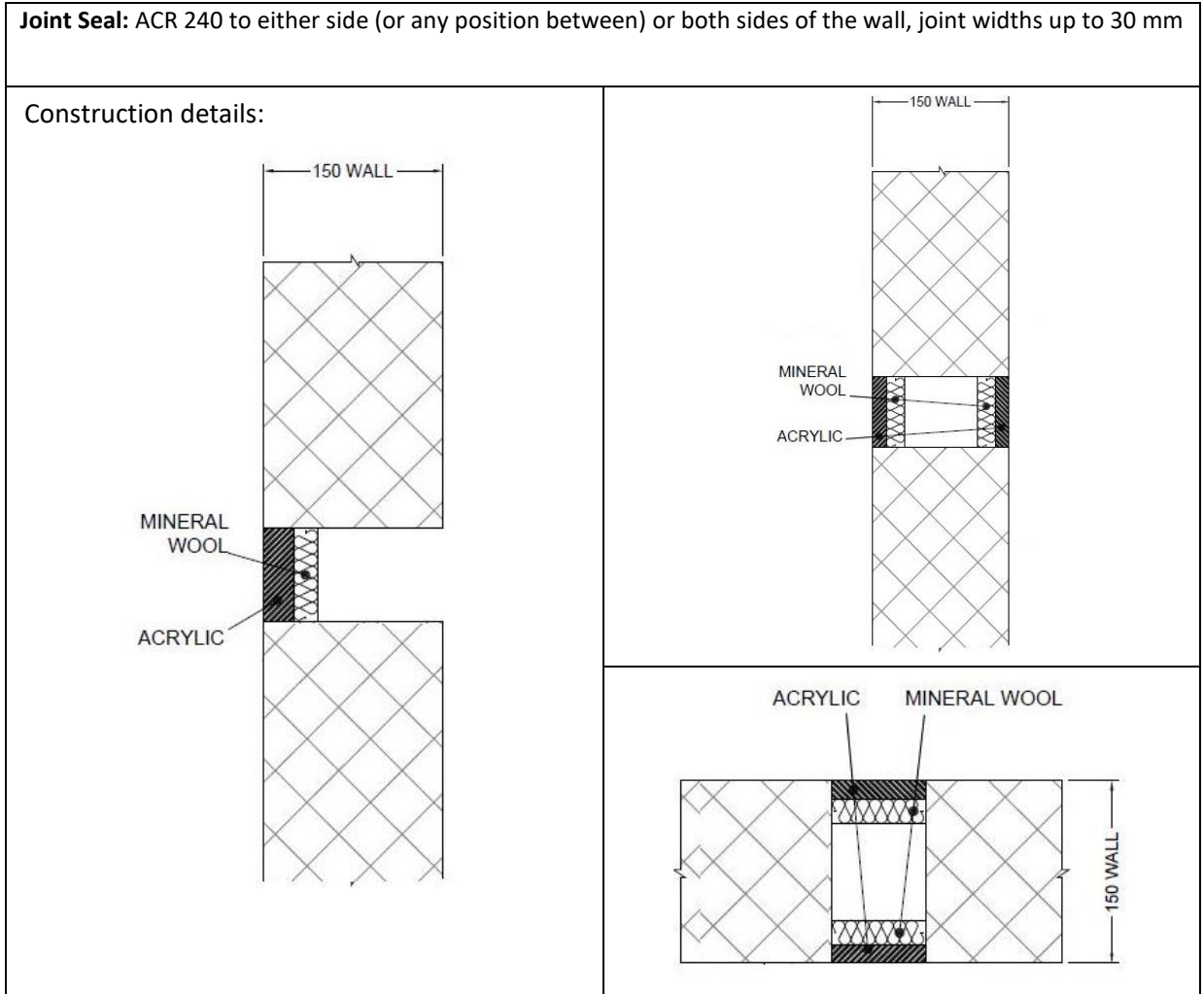

**A.3.1.1**

Substrate	Depth (mm)	Backing (minimum)	Classification
masonry/ concrete	25 min. (one side)	20 mm Stone wool 40 kg/m <sup>3</sup>	E 240 – T – X – F – W 30 EI 60 – T – X – F – W 30
	15 min. (both sides)		EI 240 – V – X – F – W 30 EI 240 – T – X – F – W 30
	10 min. (one side)	60 mm Stone wool 33 kg/m <sup>3</sup>	E 240 – T – X – F – W 50 EI 60 – T – X – F – W 50 EI 120 – V – X – F – W 50
	25 min. (one side)	48 mm Würth FP Backing	E 240 – T – X – F – W 30 EI 120 – T – X – F – W 30

**A.4 Rigid floor constructions according to 1.2.1 with floor thickness of minimum 150 mm**

**A.4.1 Linear joint or gap seal, between floor slabs or between floor slab and wall with sealant to the top face of the floor only**

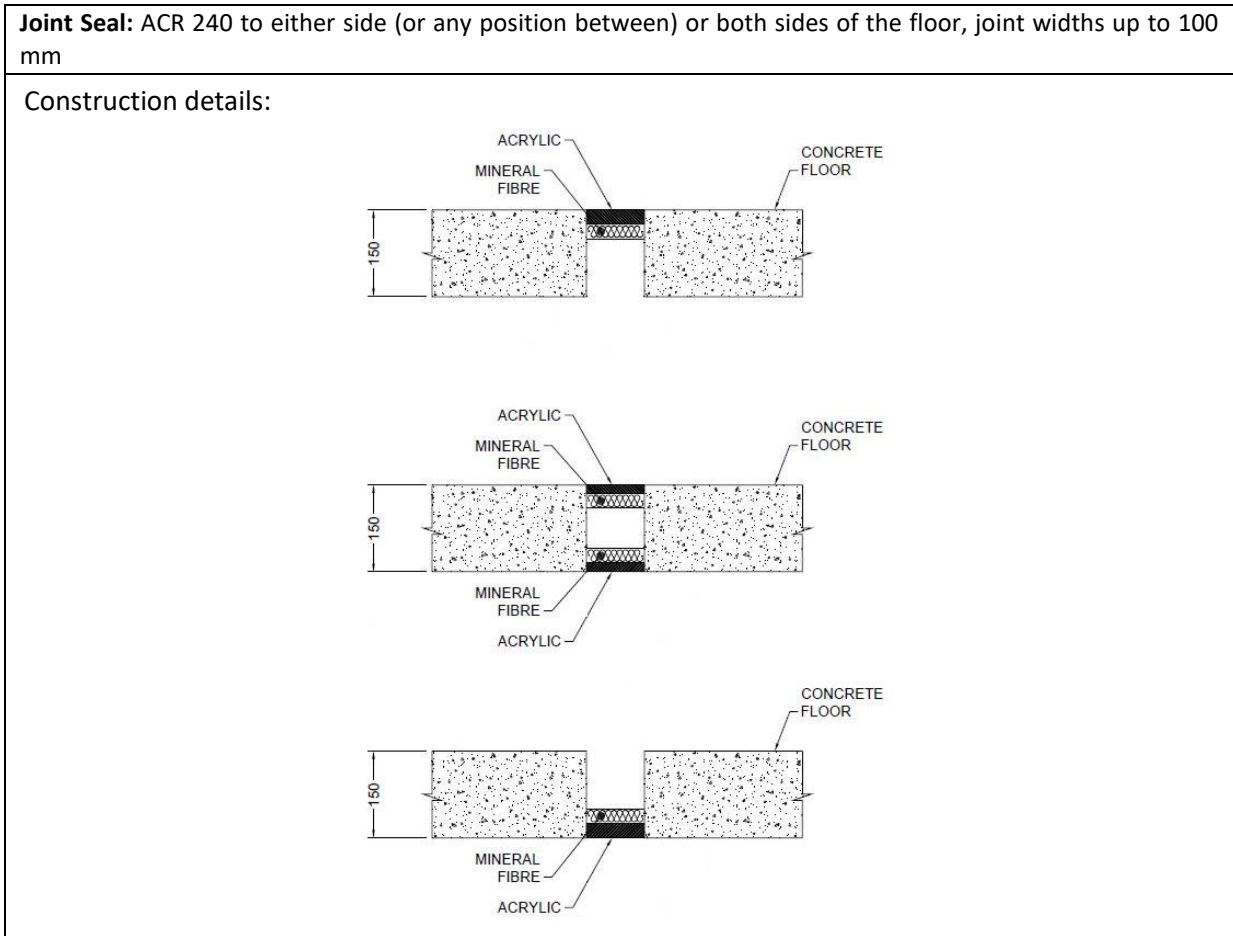

**A.4.1.1**

Substrate	Depth (mm)	Backing (minimum)	Classification
masonry/ concrete	25 min. (any position)	25 mm Würth FP Backing	<b>E 120 – H – X – F – W 100</b> <b>EI 60 – H – X – F – W 100</b>
	25 min (top face)		<b>EI 180 – H – X – F – W 100</b>
	15 min. (both sides)	25 mm Stone wool 40 kg/m <sup>3</sup>	<b>EI 120 – H – X – F – W 100</b>
		25 mm Stone wool 140 kg/m <sup>3</sup>	<b>EI 180 – H – X – F – W 100</b>
	15 min. (both sides)	25 mm stone wool 35 kg/m <sup>3</sup> insulation	<b>EI 240 – H – X – F – W 30</b>
10 min. (top face)	90 mm Stone wool 33 kg/m <sup>3</sup>	<b>EI 240 – H – X – F – W 100</b>	

#### A.4.2 Linear joint or gap seals, in or between rigid floors

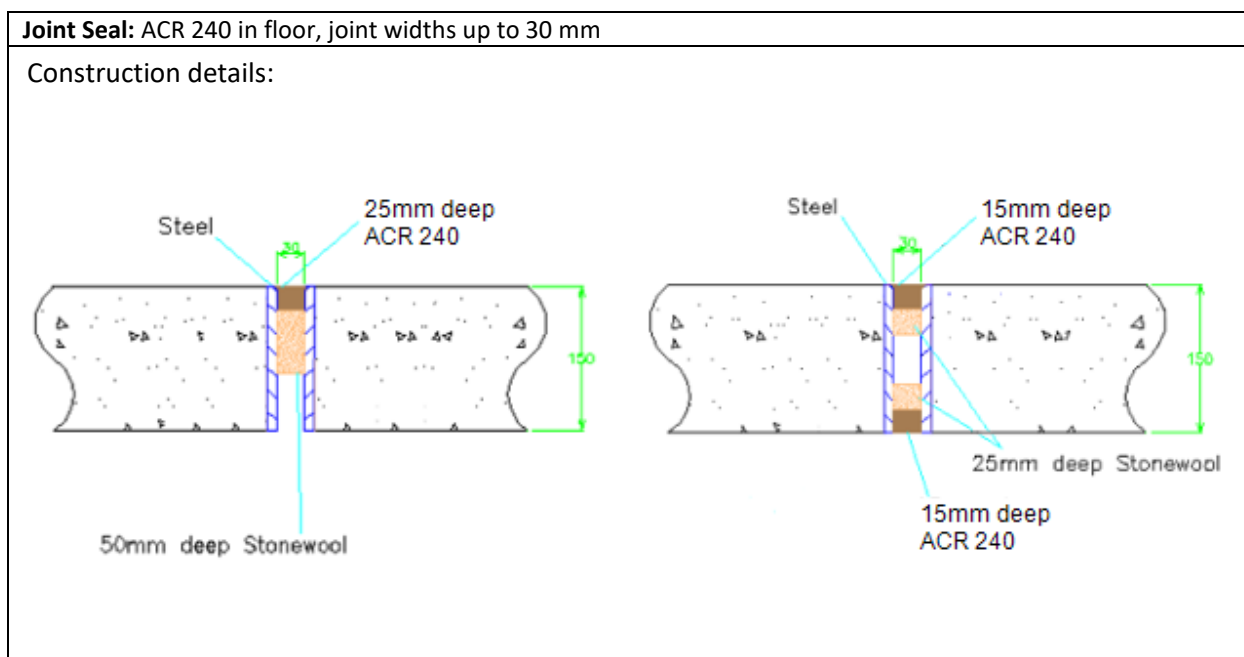

##### A.4.2.1

Substrate	Depth (mm)	Backing	Position	Classification
Steel/ steel or Steel/ concrete	25 min.	Stonewool, 50 mm deep min. 35 kg/m <sup>3</sup>	Top	<b>E 240 – H – X – F – W 30<sup>1</sup></b> <b>EI 30 – H – X – F – W 30<sup>2</sup></b>
	15 min.	Stonewool, 25 mm deep min. 35 kg/m <sup>3</sup>	Both	<b>E 240 – H – X – F – W 30<sup>3</sup></b> <b>EI 45 – H – X – F – W 30<sup>4</sup></b>
Aluminium / concrete	25 min.	Stonewool, 50 mm deep min. 35 kg/m <sup>3</sup>	Top	<b>E 180 – H – X – F – W 30<sup>5</sup></b> <b>EI 20 – H – X – F – W 30<sup>6</sup></b>

\*Additional and for information only.

The classifications provided in Table A.4.2.1 consider the insulation performance of all components within the firestopping system as per the requirements of EN 1366-4. This includes temperature evaluation of the steel substrate.

In relation to each of the above classifications, temperatures recorded on the seal (exclusive of the supporting construction) exceeded the maximum allowable after the following times (rounded down):

<sup>1</sup> 240, <sup>2</sup> 60, <sup>3</sup> 240, <sup>4</sup> 120, <sup>5</sup> 180, <sup>6</sup> 60