

Deutsches Institut für Bautechnik

Anstalt des öffentlichen Rechts

Kolonnenstr. 30 L
10829 Berlin
Germany

Tel.: +49(0)30 787 30 0
Fax: +49(0)30 787 30 320
E-mail: dibt@dibt.de
Internet: www.dibt.de

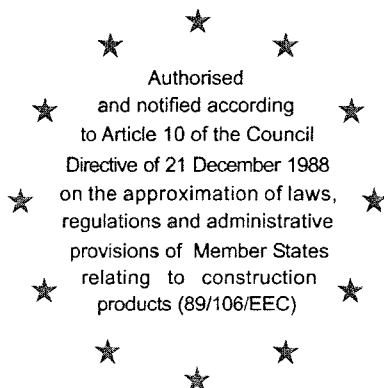

DIBt

Mitglied der EOTA
Member of EOTA

European Technical Approval ETA-02/0044

English translation prepared by DIBt - Original version in German language

Handelsbezeichnung <i>Trade name</i>	Würth-Einschlagdübel W-ED/S Würth Wedge-Anchor W-ED/S <i>Würth Wedge-Anchor W-ED/S</i>	
Zulassungsinhaber <i>Holder of approval</i>	Adolf Würth GmbH & Co. KG Reinhold-Würth-Straße 12-17 74653 Künzelsau DEUTSCHLAND	
Zulassungsgegenstand und Verwendungszweck <i>Generic type and use of construction product</i>	Wegkontrolliert spreizender Dübel aus galvanisch verzinktem Stahl in den Größen M6, M8, M10, M12, M16 und M20 zur Verankerung im ungerissenen Beton <i>Deformation-controlled expansion anchor made of galvanised steel of sizes M6, M8, M10, M12, M16 and M20 for use in non-cracked concrete</i>	
Geltungsdauer: <i>Validity:</i>	vom <i>from</i>	24 February 2004
	bis <i>to</i>	4 November 2007
	verlängert vom <i>extended from</i>	12 September 2007
	bis <i>to</i>	9 September 2012
Herstellwerk <i>Manufacturing plant</i>	Herstellwerk W1, DEUTSCHLAND	

Diese Zulassung umfasst
This Approval contains

13 Seiten einschließlich 6 Anhänge
13 pages including 6 annexes



Europäische Organisation für Technische Zulassungen
European Organisation for Technical Approvals

I LEGAL BASES AND GENERAL CONDITIONS

- 1 This European Technical Approval is issued by Deutsches Institut für Bautechnik in accordance with:
 - Council Directive 89/106/EEC of 21 December 1988 on the approximation of laws, regulations and administrative provisions of Member States relating to construction products¹, modified by Council Directive 93/68/EEC² and Regulation (EC) N° 1882/2003 of the European Parliament and of the Council³;
 - Gesetz über das In-Verkehr-Bringen von und den freien Warenverkehr mit Bauprodukten zur Umsetzung der Richtlinie 89/106/EWG des Rates vom 21. Dezember 1988 zur Angleichung der Rechts- und Verwaltungsvorschriften der Mitgliedstaaten über Bauprodukte und anderer Rechtsakte der Europäischen Gemeinschaften (Bauprodukten-gesetz - BauPG) vom 28. April 1998⁴, zuletzt geändert durch Gesetz vom 06.01.2004⁵;
 - Common Procedural Rules for Requesting, Preparing and the Granting of European Technical Approvals set out in the Annex to Commission Decision 94/23/EC⁶;
 - Guideline for European technical approval of "Metal anchors for use in concrete - Part 4: Deformation controlled expansion anchors", ETAG 001-04.
- 2 Deutsches Institut für Bautechnik is authorized to check whether the provisions of this European Technical Approval are met. Checking may take place in the manufacturing plant. Nevertheless, the responsibility for the conformity of the products to the European Technical Approval and for their fitness for the intended use remains with the holder of the European Technical Approval.
- 3 This European Technical Approval is not to be transferred to manufacturers or agents of manufacturers other than those indicated on page 1, or manufacturing plants other than those indicated on page 1 of this European Technical Approval.
- 4 This European Technical Approval may be withdrawn by Deutsches Institut für Bautechnik, in particular pursuant to information by the Commission according to Article 5(1) of Council Directive 89/106/EEC.
- 5 Reproduction of this European Technical Approval including transmission by electronic means shall be in full. However, partial reproduction can be made with the written consent of Deutsches Institut für Bautechnik. In this case partial reproduction has to be designated as such. Texts and drawings of advertising brochures shall not contradict or misuse the European Technical Approval.
- 6 The European Technical Approval is issued by the approval body in its official language. This version corresponds fully to the version circulated in EOTA. Translations into other languages have to be designated as such.

1 Official Journal of the European Communities N° L 40, 11.2.1989, p. 12
2 Official Journal of the European Communities N° L 220, 30.8.1993, p. 1
3 Official Journal of the European Union N° L 284, 31.10.2003, p. 25
4 Bundesgesetzblatt I, p. 812
5 Bundesgesetzblatt I, p.2, 15
6 Official Journal of the European Communities N° L 17, 20.1.1994, p. 34

II SPECIFIC CONDITIONS OF THE EUROPEAN TECHNICAL APPROVAL

1 Definition of product and intended use

1.1 Definition of product

The Würth Wedge-anchor W-ED/S in the range of M6, M8, M8 x 40, M10, M12, M12 x 80, M16, M16 x 80 and M20 is an anchor made of galvanised steel which is placed into a drilled hole and anchored by deformation-controlled expansion.

An illustration of the product and the intended use is given in Annex 1.

The fixture shall be fixed with a fastening screw or threaded rod according to Annex 4.

1.2 Intended use

The anchor is intended to be used for anchorages for which requirements for mechanical resistance and stability and safety in use in the sense of the Essential Requirements 1 and 4 of Council Directive 89/106 EEC shall be fulfilled and failure of anchorages made with these products would cause risk to human life and/or lead to considerable economic consequences. The anchor is to be used only for anchorages subject to static or quasi-static loading in reinforced or unreinforced normal weight concrete of strength classes C20/25 at minimum and C50/60 at most according to EN 206-1:2000-12.

It may be anchored in non-cracked concrete only.

The anchor may only be used in structures subject to dry internal conditions.

The provisions made in this European technical approval are based on an assumed intended working life of the anchor of 50 years. The indications given on the working life cannot be interpreted as a guarantee given by the producer, but are to be regarded only as a means for choosing the right products in relation to the expected economically reasonable working life of the works.

2 Characteristics of product and methods of verification

2.1 Characteristics of the product

The anchor corresponds to the drawings and provisions given in Annex 2. The characteristic material values, dimensions and tolerances of the anchor not indicated in Annex 2 shall correspond to the respective values laid down in the technical documentation⁷ of this European Technical Approval.

The characteristic values for the design of anchorages are given in Annexes 4 to 6.

Each anchor is marked with the identifying mark of the producer, the anchor identity and the thread size according to Annex 2. In addition, the expansion sleeve for anchor size M8x40 is marked on the top of the sleeve according to Annex 2.

The anchor shall only be packaged and supplied as a complete unit.

⁷ The technical documentation of this European technical approval is deposited at the Deutsches Institut für Bautechnik and, as far as relevant for the tasks of the approved bodies involved in the attestation of conformity procedure, is handed over to the approved bodies.

2.2 Methods of verification

The assessment of fitness of the anchor for the intended use in relation to the requirements for mechanical resistance and stability and safety in use in the sense of the Essential Requirements 1 and 4 has been made in accordance with the "Guideline for European technical approval of Metal Anchors for Use in Concrete", Part 1 "Anchors in general" and Part 4 "Deformation-controlled expansion anchors" on the basis of Option 7.

In addition to the specific clauses relating to dangerous substances contained in this European technical approval, there may be other requirements applicable to the products falling within its scope (e.g. transposed European legislation and national laws, regulations and administrative provisions). In order to meet the provisions of the Construction Products Directive, these requirements need also to be complied with, when and where they apply.

3 Evaluation and attestation of conformity and CE marking

3.1 System of attestation of conformity

According to the Decision 89/106/EEC of the European Commission⁸ system 2(i) (referred to as System 1) of the attestation of conformity applies.

This system of attestation of conformity is defined as follows:

System 1: Certification of the conformity of the product by an approved certification body on the basis of:

- (a) Tasks for the manufacturer:
 - (1) factory production control;
 - (2) further testing of samples taken at the factory by the manufacturer in accordance with a prescribed test plan;
- (b) Tasks for the approved body:
 - (3) initial type-testing of the product;
 - (4) initial inspection of factory and of factory production control;
 - (5) continuous surveillance, assessment and approval of factory production control.

Note: Approved bodies are also referred to as "notified bodies".

3.2 Responsibilities

3.2.1 Tasks for the manufacturer

3.2.1.1 Factory production control

The manufacturer shall exercise permanent internal control of production. All the elements, requirements and provisions adopted by the manufacturer shall be documented in a systematic manner in the form of written policies and procedures, including records of results performed. This production control system shall insure that the product is in conformity with this European technical approval.

The manufacturer may only use initial/raw/constituent materials stated in the technical documentation of this European technical approval.

The factory production control shall be in accordance with the control plan of February 2004 which is part of the technical documentation of this European technical approval. The control plan is laid down in the context of the factory production control system operated by the manufacturer and deposited with Deutsches Institut für Bautechnik.⁹

The results of factory production control shall be recorded and evaluated in accordance with the provisions of the control plan.

3.2.1.2 Other tasks for the manufacturer

The manufacturer shall, on the basis of a contract, involve a body which is approved for the tasks referred to in section 3.1 in the field of anchors in order to undertake the actions laid down in section 3.2.2. For this purpose, the control plan referred to in sections 3.2.1.1 and 3.2.2 shall be handed over by the manufacturer to the approved body involved.

The manufacturer shall make a declaration of conformity, stating that the construction product is in conformity with the provisions of this European technical approval.

3.2.2 Tasks for the approved bodies

The approved body shall perform the

- initial type-testing of the product,
- initial inspection of factory and of factory production control,
- continuous surveillance, assessment and approval of factory production control

in accordance with the provisions laid down in the control plan.

The approved body shall retain the essential points of its actions referred to above and state the results obtained and conclusions drawn in a written report.

The approved certification body involved by the manufacturer shall issue an EC certificate of conformity of the product stating the conformity with the provisions of this European technical approval.

In cases where the provisions of the European technical approval and its control plan are no longer fulfilled the certification body shall withdraw the certificate of conformity and inform Deutsches Institut für Bautechnik without delay.

3.3 CE marking

The CE marking shall be affixed on each packaging of the anchor. The letters "CE" shall be followed by the identification number of the approved certification body, where relevant, and be accompanied by the following additional information:

- the name and address of the holder of the approval (legal entity responsible for the manufacture),
- the last two digits of the year in which the CE marking was affixed,
- the number of the EC certificate of conformity for the product,
- the number of the European technical approval,
- the number of the guideline for European technical approval,
- use category (ETAG 001-1, option 7),
- size.

⁹

The control plan is a confidential part of the European technical approval and only handed over to the approved body involved in the procedure of attestation of conformity. See section 3.2.2.

4 Assumptions under which the fitness of the product for the intended use was favourably assessed

4.1 Manufacturing

The European technical approval is issued for the product on the basis of agreed data/information, deposited with Deutsches Institut für Bautechnik, which identifies the product that has been assessed and judged. Changes to the product or production process, which could result in this deposited data/information being incorrect, should be notified to Deutsches Institut für Bautechnik before the changes are introduced. Deutsches Institut für Bautechnik will decide whether or not such changes affect the approval and consequently the validity of the CE marking on the basis of the approval and if so whether further assessment or alterations to the approval shall be necessary.

4.2 Installation

4.2.1 Design of anchorages

The fitness of the anchor for the intended use is given under the following conditions:

The anchorages are designed in accordance with the "Guideline for European technical approval of Metal Anchors for Use in Concrete", Annex C, Method A under the responsibility of an engineer experienced in anchorages and concrete work.

Verifiable calculation notes and drawings are prepared taking account of the loads to be anchored.

The position of the anchor is indicated on the design drawings (e.g. position of the anchor relative to reinforcement or to supports).

The minimum strength class and the minimum screwing depth of the fastening screw or the threaded rod for installation of the fixture shall meet the requirements according to Annex 4. The length of the fastening screw shall be defined according to the requirements given in Annex 4, taking into account available thread length, the minimum screwing depth, the thickness of fixture and tolerances of member and fixture.

4.2.2 Installation of anchors

The fitness for use of the anchor can only be assumed if the anchor is installed as follows:

- Anchor installation carried out by appropriately qualified personnel and under the supervision of the person responsible for technical matters of the site.
- Use of the anchor only as supplied by the manufacturer without exchanging the components of an anchor.
- Anchor installation in accordance with the manufacturer's specifications and drawings and using the appropriate tools specified in Annex 2;
- Checks before placing the anchor to ensure that the strength class of the concrete in which the anchor is to be placed is in the range given and is not lower than that of the concrete to which the characteristic loads apply.
- Check of concrete being well compacted, e.g. without significant voids.
- Positioning of the drill holes without damaging the reinforcement.
- Clearing of the hole of drilling dust.
- Edge distance and spacing not less than the specified values without minus tolerances.
- In case of aborted hole: new drilling at a minimum distance away of twice the depth of the aborted hole or smaller distance if the aborted drill hole is filled with high strength mortar and if under shear or oblique tension load it is not in the direction of load application.
- Anchor installation such that the effective setting depth is complied with. This compliance is ensured, if the expansion sleeve does not exceed the concrete surface.

- Anchor expansion by impact on the cone using the setting tools given in Annex 3. The anchor is properly set if the stop of the pin reaches the expansion sleeve, and the impression of the setting tool for marking is visible as illustrated in Annex 3.
- The fastening screw or threaded rod shall correspond to the requirements given in Annex 4.
- Fixing the screw with the recommended torque moment given in Annex 3 using a calibrated torque wrench.

4.2.3 Responsibility of the manufacturer

It is in the responsibility of the manufacturer to ensure that the information on the specific conditions according to 1 and 2 including Annexes referred to and 4.2.1 and 4.2.2 is given to those who are concerned. This information may be made by reproduction of the respective parts of the European technical approval. In addition all installation data shall be shown clearly on the package and/or on an enclosed instruction sheet, preferably using illustration(s).

The minimum data required are:

- drill bit diameter,
- thread diameter,
- minimum effective anchorage depth,
- available thread length and minimum screwing depth of the fastening screw or threaded rod,
- minimum strength class of the screw or threaded rod according to EN ISO 898-1
- minimum hole depth,
- torque moment,
- information on the installation procedure, including cleaning of the hole, preferably by means of an illustration,
- reference to any special installation equipment needed,
- identification of the manufacturing batch.

All data shall be presented in a clear and explicit form.

I. V. Dipl.-Ing. Seyfert
Vice-President of Deutsches Institut für Bautechnik
Berlin, 12 September 2007

beglaubigt:
Lange

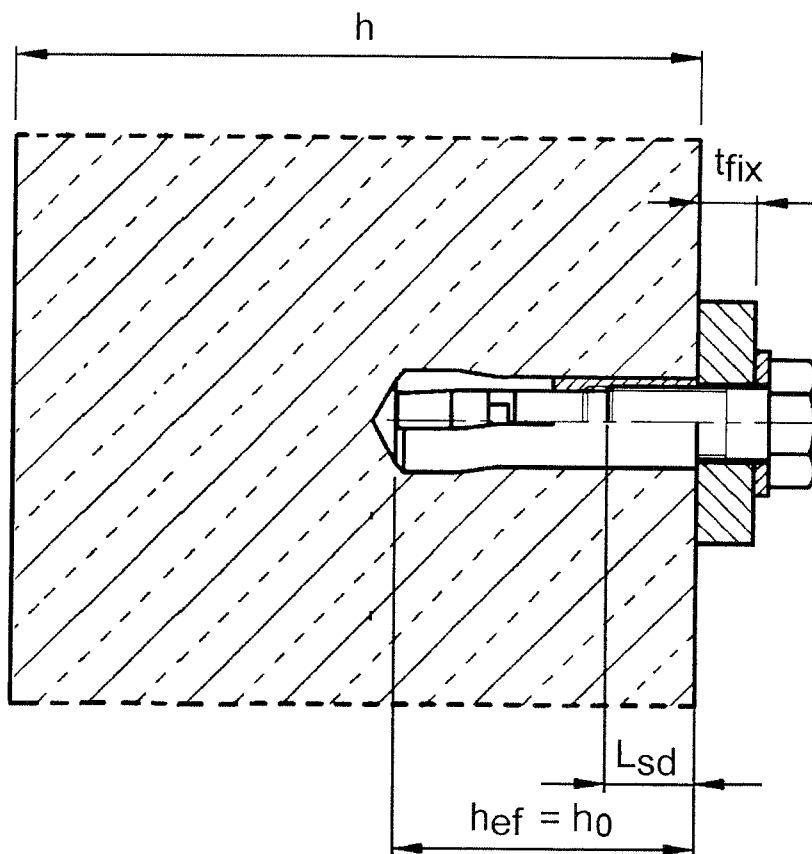
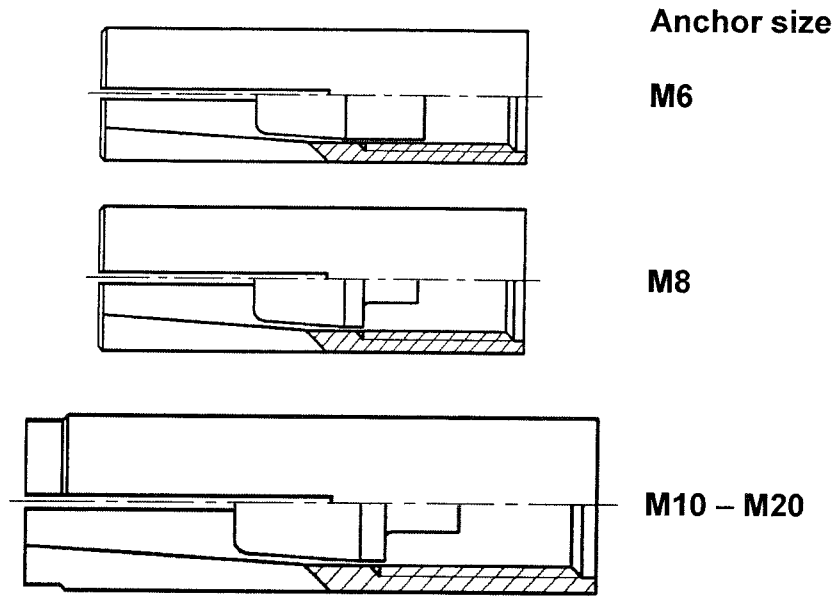

Würth Wedge-Anchor W-ED/S

Product and intended use

Annex 1

of European
technical approval

ETA-02/0044

Expansion sleeve

marking: e.g.:

◇ E M8

◇ Identifying mark of manufacturing plant

E Anchor identity

M8 Size of thread

Anchor size: M8x40

additional marking d, visible after installation

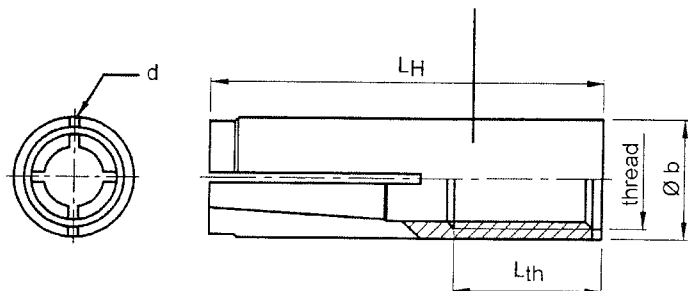

**Cone
Size M6**

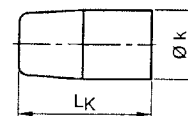

Size M8 – M20

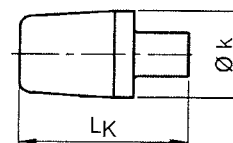

Table 1: Dimensions [mm]

Anchor size	expansion sleeve				cone	
	thread	Ø b	L _H	L _{th}	Ø k	L _k
M6	M6	8	30	13	6.5	12
M8	M8	10	30	13		
M8x40	M8	10	40	20	8.2	16
M10	M10	12	40	15		
M12	M12	15	50	18	10.3	20
M12x80	M12	15	80	45		
M16	M16	19.7	65	23	13.8	29
M16x80	M16	19.7	80	38		
M20	M20	24.7	80	34	16.5	30

Table 2: Designation of anchor parts and material

Part	Designation of anchor parts	materials, zinc coated ≥ 5 µm, acc. to EN ISO 4042
1	expansion sleeve	free-cutting steel acc. to EN 10 087
2	cone	steel for cold forming acc. to EN 10 263

Würth Wedge-Anchor W-ED/S

Dimensions and materials

Annex 2

of European technical approval

ETA-02/0044

Setting tool for marking

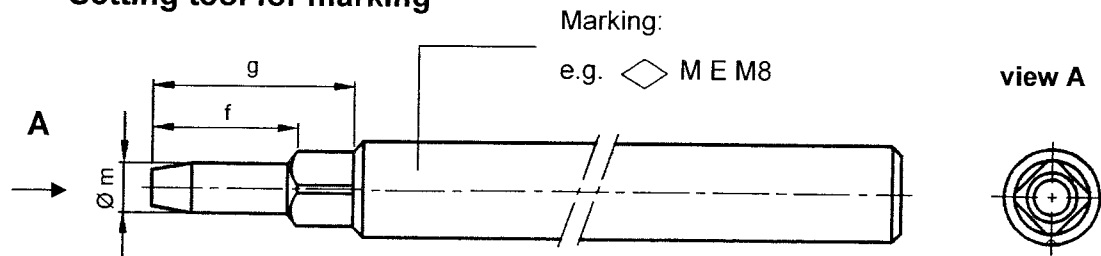

Verification of correct installation with setting tool marking

The setting tool leaves a visible marking after correct installation.

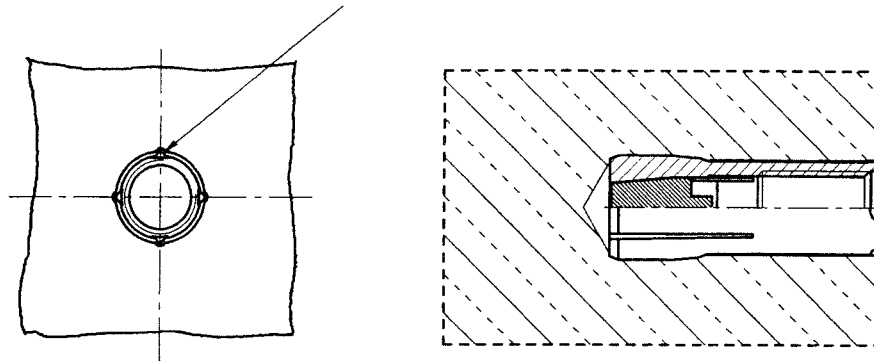

Setting tool

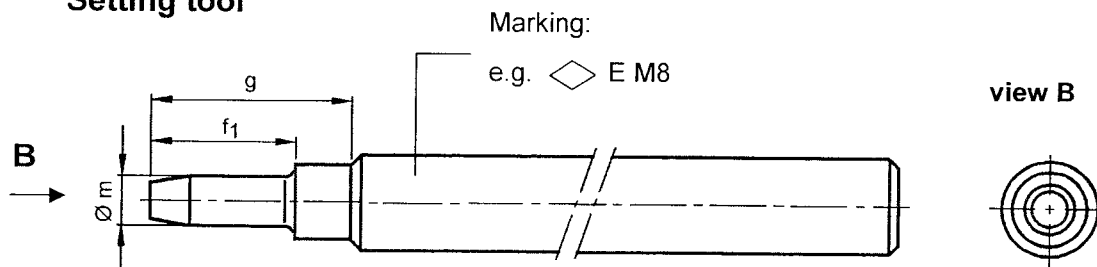

Table 3: Dimensions of setting tools [mm]

Anchor size	Ø m	f	f ₁	g
M6	4.9	-	17	27
M8	6.4	18.2	18	28
M8x40	6.4	28.2	28	38
M10	8.0	24.2	24	34
M12	10.0	30.4	30	40
M12x80	10.0	60.4	60	70
M16	13.5	36.6	36	46
M16x80	13.5	51.6	51	61
M20	16.5	50.7	50	60

Würth Wedge-Anchor W-ED/S

Dimensions of setting tools and verification of correct installation

Annex 3

of European technical approval

ETA-02/0044

Table 4: Installation parameters

Anchor size		M6	M8	M8x40	M10	M12	M12x80	M16	M16x80	M20
Depth of drill hole	$h_0 =$ [mm]	30	30	40	40	50	80	65	80	80
Drill hole diameter	$d_0 =$ [mm]	8	10	10	12	15	15	20	20	25
Cutting diameter of drill bit	$d_{cut} \leq$ [mm]	8.45	10.45	10.45	12.5	15.5	15.5	20.55	20.55	25.55
Recommended setting torque	$T_{inst} =$ [Nm]	4	8	8	15	35	35	60	60	120
Diameter of clearance hole in the fixture	$d_f \leq$ [mm]	7	9	9	12	14	14	18	18	22
Available thread length	L_{th} [mm]	13	13	20	15	18	45	23	38	34
Minimum screwing depth	L_{sdmin} [mm]	7	9	9	11	13	13	18	18	22
Minimum thickness of member	h_{min} [mm]	100	100	100	120	130	130	160	160	200
Minimum spacing and	s_{min} [mm]	55	60	80	100	120	120	150	150	160
Edge distance	c_{min} [mm]	95	95	95	135	165	165	200	200	260

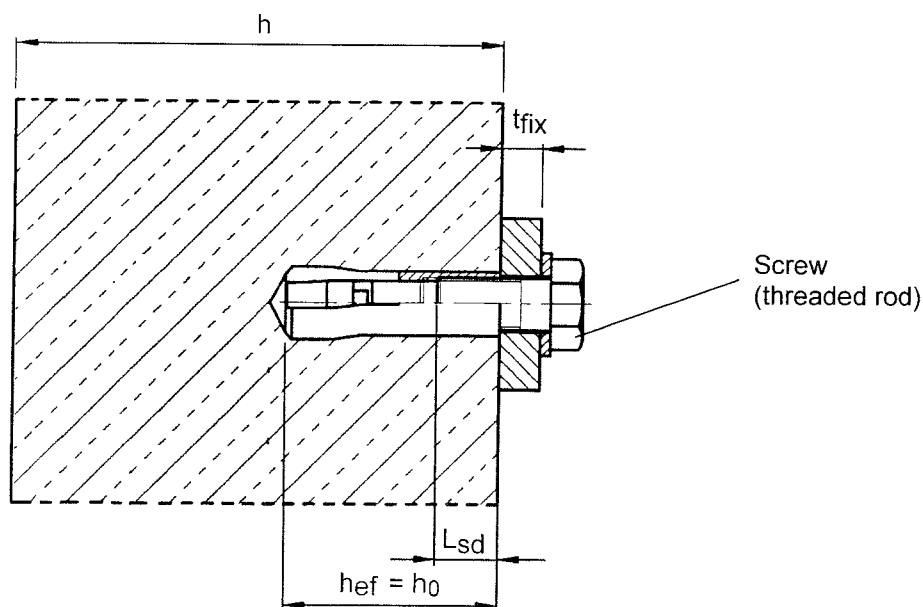
**Requirements for the fastening screw or threaded rod:**

- Minimum strength class 4.6 acc. to EN ISO 898-1;
- Minimum screwing depth L_{sdmin} see Table 4;
- The length of the fastening screw shall be determined on thickness of fixture t_{fix} , admissible tolerances, available thread length L_{th} (= maximum screwing depth) and minimum screwing depth L_{sdmin}

Würth Wedge-Anchor W-ED/S**Installation parameters****Annex 4**of European
technical approval**ETA-02/0044**

Table 5: Design method A, characteristic values for tension loads

Anchor size			M6 ¹⁾	M8 ¹⁾	M8x40	M10	M12 M12x80	M16 M16x80	M20	
Steel failure										
Characteristic resistance Steel 4.6	$N_{Rk,s}$	[kN]	8.0	14.6	23.2	33.7	62.8	98.0		
Partial safety factor	γ_{Ms} ⁴⁾	[-]	2.0							
Characteristic resistance Steel 5.6	$N_{Rk,s}$	[kN]	10.0	18.3	29.0	42.1	78.3	122.4		
Partial safety factor	γ_{Ms} ⁴⁾	[-]	2.0							
Characteristic resistance Steel 5.8	$N_{Rk,s}$	[kN]	10.0	18.3	25.2	42.1	67.1	106.4		
Partial safety factor	γ_{Ms} ⁴⁾	[-]	1.5				1.6			
Characteristic resistance Steel 8.8	$N_{Rk,s}$	[kN]	16.0	19.9	25.2	43.0	67.1	106.4		
Partial safety factor	γ_{Ms} ⁴⁾	[-]	1.5				1.6			
Pull out failure										
Characteristic resistance in non-cracked concrete	$N_{Rk,p}$ C20/25	[kN]	²⁾	²⁾	9	²⁾	²⁾	²⁾	²⁾	
Increasing factor for $N_{Rk,p}$ for non-cracked concrete	ψ_C	C30/37	[-]		1.12					
		C40/50	[-]		1.23					
		C50/60	[-]		1.3					
Partial safety factor	γ_{Mc} ⁴⁾	[-]			1.8					
Concrete cone failure and splitting										
Effective anchorage depth	$h_{ef} = h_0$	[mm]	30	30	40	40	50	65	80	
Spacing	$s_{cr,N}$	[mm]	3 h_{ef}							
	$s_{cr,Sp}$	[mm]	190	190	190	270	330	400	520	
Edge distance	$c_{cr,N}$	[mm]	1.5 h_{ef}							
	$c_{cr,Sp}$	[mm]	95	95	95	135	165	200	260	
Partial safety factor	$\gamma_{Mc} = \gamma_{M,sp}$ ^{3) 4)}	[-]	1.8	2.1	1.8					

¹⁾ Use restricted to anchoring of structural components statically indetermined

²⁾ Pullout failure mode not decisive

³⁾ In absence of other national regulations

⁴⁾ The partial safety factor γ_2 is included

Table 6: Displacements under tension loads

Anchor size			M6	M8	M8x40	M10	M12	M16	M20
Tension load in non-cracked concrete	N	[kN]	3	3	3.6	4.8	6,4	10	14.8
Displacement	δ_{N0}	[mm]	0.24						
	δ_{N20}	[mm]	0.36						

Würth Wedge-Anchor W-ED/S

**Design method A,
Characteristic values for tension loads,
Displacements**

Annex 5

of European
technical approval

ETA-02/0044

Table 7: Design method A, characteristic values for shear loads

Anchor size			M6	M8	M8x40	M10	M12 M12x80	M16 M16x80	M20	
Steel failure without lever arm										
Characteristic resistance Steel 4.6	$V_{Rk,s}$	[kN]	3.8	7.3	9.6	16.8	31.3	49.0		
Partial safety factor	$\gamma_{Ms}^{1)}$	[-]	1.67							
Characteristic resistance Steel 5.6	$V_{Rk,s}$	[kN]	5.0	9.1	9.6	21.0	39.2	61.2		
Partial safety factor	$\gamma_{Ms}^{1)}$	[-]	1.67							
Characteristic resistance Steel 5.8	$V_{Rk,s}$	[kN]	5.0	6.9	7.2	21.0	33.5	53.2		
Partial safety factor	$\gamma_{Ms}^{1)}$	[-]	1.25				1.33			
Characteristic resistance Steel 8.8	$V_{Rk,s}$	[kN]	5,0	6,9	7,2	21,0	33,5	53,2		
Partial safety factor	$\gamma_{Ms}^{1)}$	[-]	1.25				1.33			
Steel failure with lever arm										
Characteristic resistance Steel 4.6	$M_{Rk,s}^0$	[Nm]	6.1	15	30	52	133	259		
Partial safety factor	$\gamma_{Ms}^{1)}$	[-]	1.67							
Characteristic resistance Steel 5.6	$M_{Rk,s}^0$	[Nm]	7.6	19	37	65	166	324		
Partial safety factor	$\gamma_{Ms}^{1)}$	[-]	1.67							
Characteristic resistance Steel 5.8	$M_{Rk,s}^0$	[Nm]	7.6	19	37	65	166	324		
Partial safety factor	$\gamma_{Ms}^{1)}$	[-]	1.25							
Characteristic resistance Steel 8.8	$M_{Rk,s}^0$	[Nm]	12	30	60	105	266	519		
Partial safety factor	$\gamma_{Ms}^{1)}$	[-]	1.25							
Concrete pryout failure										
Factor in equation (5.6) ETAG Annex C, 5.2.3.3	k	[-]	1.0	1.0	1.5	2.0	2.0			
Partial safety factor	$\gamma_{MCP}^{1) 2)}$	[-]	1.5							
Concrete edge failure										
Effective length of anchor under shear loading	l_f	[mm]	30	30	40	40	50	65	80	
Outside diameter of anchor	d_{nom}	[mm]	8	10	10	12	15	20	25	
Partial safety factor	$\gamma_{Mc}^{1) 2)}$	[-]	1.5							

¹⁾ In absence of other national regulations

²⁾ The partial safety factor $\gamma_2 = 1.0$ is included

Table 8: Displacements under shear loads

Anchor size			M6	M8	M8x40	M10	M12 M12x80	M16 M16x80	M20
Shear load in non-cracked concrete	V	[kN]	2	4	4	4	11.3	18.8	32.2
Displacement	δ_{V0}	[mm]	0.9	0.9	1.0	0.6	1.2	1.2	1.6
	$\delta_{V\infty}$	[mm]	1.3	1.3	1.5	0.9	1.9	1.9	2.4

Würth Wedge-Anchor W-ED/S

**Design method A,
Characteristic values for shear loads,
Displacements**

Annex 6

of European
technical approval

ETA-02/0044