

Technical Data	Combi T	
-----------------------	----------------	--

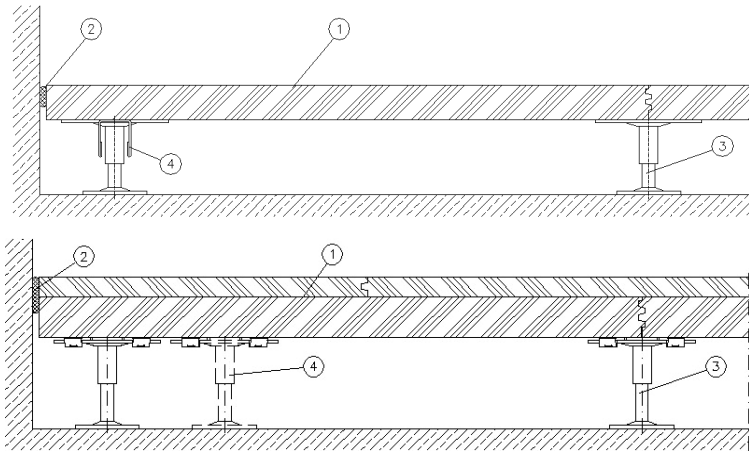

- 1 Panel
- 2 Self adhesive foam tape
- 3 Pedestal
- 4 Reinforcement

	Calcium sulphate	Wood
System:		
Panel material:	calcium sulphate 28 - 80 mm	chipboard panel 30 - 38 mm
Dimension:	600 x 600 mm (ZF)	
Surface:	-	optional with aluminium foil
Underside:	optional steel sheet	No coating with application at factory
System weight:	~ 38 - 131 kg/m ²	~ 23 - 29 kg/m ²
Adhesive:	Step rabbet glued by means of high-quality solvent-free adhesive	

Understructure:		
Module:	600 x 600 mm	
Pedestal material:	galvanized steel	
Construction height:	from ~50 mm FFH	
Fixing of pedestals:	pedestal base plate glued to the subfloor	

Floor coverings:	textile and elastic floor coverings, parquet, natural and artificial stone, ceramic	textile and elastic floor coverings, parquet
-------------------------	---	--

Load values:		
Point load:	3.000 - 25.000 N	2.000 - 3.000 N
Load class according to EN 13213:	Class 2 - 6	Class 1 - 2
Ultimate load:	≥ 6.000 - 50.000 N	≥ 4.000 - 6.000 N
Safety factor:	≥ 2,0	

Fire protection:		
Building material class		
acc. to EN 13501 T1:	A1	C – s2, d0 flame retardant
Fire resistance class acc. to DIN 4102 T2:	F30	F30 possible

Acoustic values:		
depending on system and floor covering (only calcium sulphate systems)		
New terms acc. to DIN EN		
• sound reduction index $R_{L,w,P}$	40 – 55 dB	Standard flank level difference $D_{n,f,w,P}$
• normalized impact sound pressure level $L_{n,w,P}$	83 – 33 dB	Standard flank impact sound level $L_{n,f,w,P}$
• improvement of sound pressure level reduction $\Delta L_{w,P}$	15 – 33 dB	Impact sound reduction $\Delta L_{w,P}$