

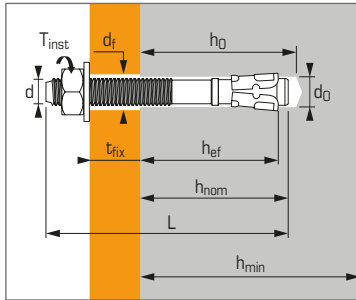

## Torque controlled expansion anchor, for use in non-cracked concrete



### APPLICATION

- Steel and timber framework and beams
- Lift guide rails
- Industrial doors and gates
- Brickwork support angles
- Storage systems

### MATERIAL

- Hot dip galvanised: 45 µm NF EN ISO 1460 -1461
- Salt spray: >350 hours

### Technical data

Anchor size	Letter marking	Minimum anchorage depth					Maximum anchorage depth					Thread diameter (mm)	Drilling diameter (mm)	Clearance diameter (mm)	Total anchor length (mm)	Tighten torque (Nm)	Code
		min. anchor depth (mm)	Embed. depth (mm)	Max. thick. of part to be fixed (mm)	Drilling depth (mm)	Min. thick. of base material (mm)	max. anchor depth (mm)	Embed. depth (mm)	Max. thick. of part to be fixed (mm)	Drilling depth (mm)	Min. thick. of base material (mm)						
		<b>h<sub>ef</sub></b>	<b>h<sub>nom</sub></b>	<b>t<sub>fix</sub></b>	<b>h<sub>0</sub></b>	<b>h<sub>min</sub></b>	<b>h<sub>ef</sub></b>	<b>h<sub>nom</sub></b>	<b>t<sub>fix</sub></b>	<b>h<sub>0</sub></b>	<b>h<sub>min</sub></b>	<b>d</b>	<b>d<sub>0</sub></b>	<b>d<sub>f</sub></b>	<b>L</b>	<b>T<sub>inst</sub></b>	
8X70/20-7	C			20					7						70		050310
8X90/40-27	E	35	42	40	52	100	48	55	27	65	100	8	8	9	90	15	050320
8X110/60-47	F			60					47						110		050329
8X130/80-67	H			80					67						130		050330
10X75/15-5	C			15					5						75		050350
10X95/36-26	E			36					26						96		050360
10X120/60-50	G	42	50	60	62	100	52	60	50	72	104	10	10	12	120	30	050340
10X140/80-70	I			80					70						140		050370
10X160/100-90	J			100					90						160		050341
12X80/5	-			5					-						80		055351
12X100/25-8	E			25					8						100		055352
12X115/40-23	G	50	60	40	75	100	68	78	23	93	136	12	12	14	115	50	055395
12X140/65-48	I			65					48						140		050400
12X180/105-88	L			105					88						180		050410
16X125/30-8	G			30					8						125		050440
16X150/55-33	I	64	78	55	95	128	86	100	33	117	172	16	16	18	150	100	050354
16X170/75-53	K			75					53						170		050450

### INSTALLATION

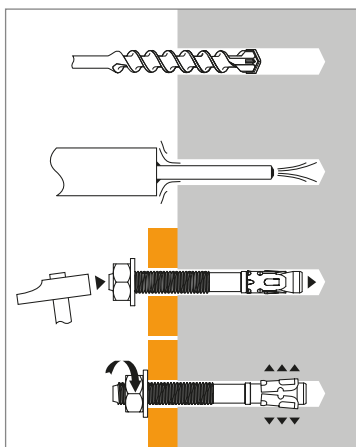

### Anchor mechanical properties

Anchor size		M8	M10	M12	M16
<b>Cross-section above cone</b>					
<b>f<sub>uk</sub></b> (N/mm <sup>2</sup> )	Min. tensile strength	700	700	700	600
<b>f<sub>yk</sub></b> (N/mm <sup>2</sup> )	Yield strength	580	580	580	500
<b>A<sub>s</sub></b> (mm <sup>2</sup> )	Stressed cross-section	23,76	40,72	55,42	103,87
<b>Threaded part</b>					
<b>f<sub>uk</sub></b> (N/mm <sup>2</sup> )	Min. tensile strength	600	600	600	500
<b>f<sub>yk</sub></b> (N/mm <sup>2</sup> )	Yield strength	480	480	480	400
<b>A<sub>s</sub></b> (mm <sup>2</sup> )	Stressed cross-section	36,6	58	84,3	157
<b>W<sub>el</sub></b> (mm <sup>3</sup> )	Elastic section modulus	31,23	62,3	109,17	277,47
<b>M<sup>0</sup><sub>rk,s</sub></b> (Nm)	Characteristic bending moment	22	45	79	166
<b>M</b> (Nm)	Recommended bending moment	9,0	18,4	32,2	67,8

# FIX II - HDG

2/4 hot dip galvanised version



The loads specified on this page allow judging the product's performances, but cannot be used for the designing. The data given in the pages "CC method" have to be applied (3/4 and 4/4).

## Ultimate ( $N_{Ru,m}$ , $V_{Ru,m}$ ) and characteristic loads ( $N_{Rk}$ , $V_{Rk}$ ) in kN

Mean Ultimate loads are derived from test results in admissible service conditions, and characteristic loads are statistically determined.

### TENSILE

Anchor size	M8	M10	M12	M16
<b>Minimum anchorage depth</b>				
$h_{ef}$	<b>35</b>	<b>42</b>	<b>50</b>	<b>64</b>
$N_{Ru,m}$	13,4	14,0	23,6	30,6
$N_{Rk}$	8,1	9,9	15,9	22,9
<b>Maximum anchorage depth</b>				
$h_{ef}$	<b>48</b>	<b>52</b>	<b>68</b>	<b>86</b>
$N_{Ru,m}$	17,8	18,7	32,7	51,0
$N_{Rk}$	15,1	15,5	26,0	39,9

### SHEAR

Anchor size	M8	M10	M12	M16
$V_{Ru,m}$	10,8	18,2	30,8	44,7
$V_{Rk}$	5,3	15,6	25,6	30,4

Mechanical anchors

## Design loads ( $N_{Rd}$ , $V_{Rd}$ ) for one anchor without edge or spacing influence in kN

$$N_{Rd} = \frac{N_{Rk}^*}{\gamma_{Mc}}$$

\*Derived from test results

$$V_{Rd} = \frac{V_{Rk}^*}{\gamma_{Ms}}$$

### TENSILE

Anchor size	M8	M10	M12	M16
<b>Minimum anchorage depth</b>				
$h_{ef}$	<b>35</b>	<b>42</b>	<b>50</b>	<b>60</b>
$N_{Rd}$	4,5	5,5	8,8	12,7
<b>Maximum anchorage depth</b>				
$h_{ef}$	<b>48</b>	<b>52</b>	<b>68</b>	<b>86</b>
$N_{Rd}$	8,4	8,6	14,4	22,1

$$\gamma_{Mc} = 1,8$$

### SHEAR

Anchor size	M8	M10	M12	M16
$V_{Rd}$	5,8	9,2	13,3	24,8

$$\gamma_{Ms} = 1,25$$

## Recommended loads ( $N_{rec}$ , $V_{rec}$ ) for one anchor without edge or spacing influence in kN

$$N_{rec} = \frac{N_{Rk}^*}{\gamma_M \cdot \gamma_F}$$

\*Derived from test results

$$V_{rec} = \frac{V_{Rk}^*}{\gamma_M \cdot \gamma_F}$$

### TENSILE

Anchor size	M8	M10	M12	M16
<b>Minimum anchorage depth</b>				
$h_{ef}$	<b>35</b>	<b>42</b>	<b>50</b>	<b>64</b>
$N_{rec}$	3,2	3,9	6,3	9,0
<b>Maximum anchorage depth</b>				
$h_{ef}$	<b>48</b>	<b>52</b>	<b>68</b>	<b>86</b>
$N_{rec}$	6,0	6,1	10,3	15,8

$$\gamma_F = 1,4 ; \gamma_{Mc} = 1,8$$

### SHEAR

Anchor size	M8	M10	M12	M16
$V_{rec}$	3,0	8,9	14,6	17,4

$$\gamma_F = 1,4 ; \gamma_{Ms} = 1,25$$



## SPIT CC Method

### TENSILE in kN

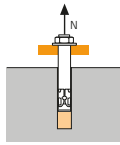

#### → Pull-out resistance

$$N_{Rd,p} = N^0_{Rd,p} \cdot f_b$$

$N^0_{Rd,p}$	Design pull-out resistance			
Anchor size	M8	M10	M12	M16
<b>Minimum anchorage depth</b>				
$h_{ef}$	<b>35</b>	<b>42</b>	<b>50</b>	<b>64</b>
$N^0_{Rd,p}$ (C20/25)	3,3	5,0	8,9	13,9
<b>Maximum anchorage depth</b>				
$h_{ef}$	<b>48</b>	<b>52</b>	<b>68</b>	<b>86</b>
$N^0_{Rd,p}$ (C20/25)	5,0	6,7	11,1	22,2

$\gamma_{Mc} = 1,8$

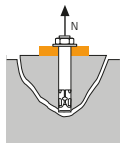

#### → Concrete cone resistance

$$N_{Rd,c} = N^0_{Rd,c} \cdot f_b \cdot \Psi_s \cdot \Psi_{c,N}$$

$N^0_{Rd,c}$	Design cone resistance			
Anchor size	M8	M10	M12	M16
<b>Minimum anchorage depth</b>				
$h_{ef}$	<b>35</b>	<b>42</b>	<b>50</b>	<b>64</b>
$N^0_{Rd,c}$ (C20/25)	5,8	7,6	9,9	14,3
<b>Maximum anchorage depth</b>				
$h_{ef}$	<b>48</b>	<b>52</b>	<b>68</b>	<b>86</b>
$N^0_{Rd,c}$ (C20/25)	9,3	10,5	15,7	22,3

$\gamma_{Mc} = 1,8$

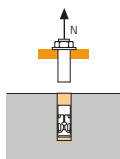

#### → Steel resistance

$V_{Rd,s}$	Steel design tensile resistance			
Anchor size	M8	M10	M12	M16
$V_{Rd,s}$	9,3	16	22	34

$\gamma_{Ms} = 1,5$

### SHEAR in kN

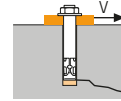

#### → Concrete edge resistance

$$V_{Rd,c} = V^0_{Rd,c} \cdot f_b \cdot f_{\beta,V} \cdot \Psi_{S-C,V}$$

$V^0_{Rd,c}$	Design concrete edge resistance at minimum edge distance ( $C_{min}$ )			
Anchor size	M8	M10	M12	M16
<b>Minimum anchorage depth</b>				
$h_{ef}$	<b>35</b>	<b>42</b>	<b>50</b>	<b>64</b>
$C_{min}$	55	75	100	100
$S_{min}$	45	65	100	100
$V^0_{Rd,c}$ (C20/25)	2,9	5,1	8,7	10,1
<b>Maximum anchorage depth</b>				
$h_{ef}$	<b>48</b>	<b>52</b>	<b>68</b>	<b>86</b>
$C_{min}$	60	65	90	105
$S_{min}$	50	55	75	90
$V^0_{Rd,c}$ (C20/25)	3,7	4,4	8,2	11,8

$\gamma_{Mc} = 1,5$

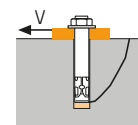

#### → Pryout failure

$$V_{Rd,cp} = V^0_{Rd,cp} \cdot f_b \cdot \Psi_s \cdot \Psi_{c,N}$$

$V^0_{Rd,cp}$	Design pryout resistance			
Anchor size	M8	M10	M12	M16
<b>Minimum anchorage depth</b>				
$h_{ef}$	<b>35</b>	<b>42</b>	<b>50</b>	<b>64</b>
$V^0_{Rd,cp}$ (C20/25)	7,0	9,1	11,9	34,4
<b>Maximum anchorage depth</b>				
$h_{ef}$	<b>48</b>	<b>52</b>	<b>68</b>	<b>86</b>
$V^0_{Rd,cp}$ (C20/25)	11,2	12,6	37,7	53,6

$\gamma_{Mcp} = 1,5$

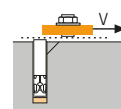

#### → Steel resistance

$V_{Rd,s}$	Steel design shear resistance			
Anchor size	M8	M10	M12	M16
$V_{Rd,s}$	3,8	11,2	18,2	18,9

$\gamma_{Ms} = 1,25$

$$N_{Rd} = \min(N_{Rd,p} ; N_{Rd,c} ; N_{Rd,s})$$

$$\beta_N = N_{Sd} / N_{Rd} \leq 1$$

$$V_{Rd} = \min(V_{Rd,c} ; V_{Rd,cp} ; V_{Rd,s})$$

$$\beta_V = V_{Sd} / V_{Rd} \leq 1$$

$$\beta_N + \beta_V \leq 1,2$$

### $f_b$ INFLUENCE OF CONCRETE

Concrete class	$f_b$	Concrete class	$f_b$
C25/30	1,1	C40/50	1,41
C30/37	1,22	C45/55	1,48
C35/45	1,34	C50/60	1,55

### $f_{\beta,V}$ INFLUENCE OF SHEAR LOADING DIRECTION

Angle $\beta$ [°]	$f_{\beta,V}$
0 to 55	1
60	1,1
70	1,2
80	1,5
90 to 180	2

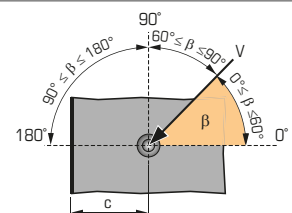



### SPIT CC Method

#### $\Psi_s$ INFLUENCE OF SPACING FOR CONCRETE CONE RESISTANCE IN TENSILE LOAD

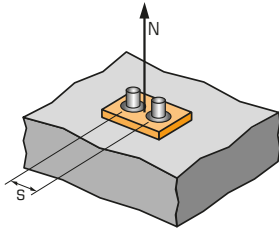

$$\Psi_s = 0,5 + \frac{s}{6 \cdot h_{ef}}$$

$$s_{min} < s < s_{cr,N}$$

$$s_{cr,N} = 3 \cdot h_{ef}$$

$\Psi_s$  must be used for each spacing influenced the anchors group

SPACING S	Reduction factor $\Psi_s$ Minimum anchorage depth			
	Anchor size M8	M10	M12	M16
45	0,71			
65	0,81	0,76		
100	0,98	0,90	0,83	0,76
110	1,00	0,94	0,87	0,79
125		1,00	0,92	0,83
150			1,00	0,89
180				0,97
192				1,00

SPACING S	Reduction factor $\Psi_s$ Maximum anchorage depth			
	Anchor size M8	M10	M12	M16
50	0,67			
55	0,69	0,68		
75	0,76	0,74	0,68	
90	0,81	0,79	0,72	0,67
105	0,86	0,84	0,76	0,70
145	1,00	0,96	0,86	0,78
180		1,00	0,94	0,85
205			1,00	0,90
240				0,97
280				1,00

#### $\Psi_{c,N}$ INFLUENCE OF EDGE FOR CONCRETE CONE RESISTANCE IN TENSILE LOAD

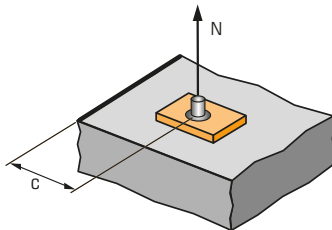

$$\Psi_{c,N} = 0,23 + 0,51 \cdot \frac{c}{h_{ef}}$$

$$c_{min} < c < c_{cr,N}$$

$$c_{cr,N} = 1,5 \cdot h_{ef}$$

$\Psi_{c,N}$  must be used for each distance influenced the anchors group.

EDGE C	Reduction factor $\Psi_{c,N}$ Minimum anchorage depth			
	Anchor size M8	M10	M12	M16
55	1,00			
65		1,00		
100			1,00	
100				1,00

EDGE C	Reduction factor $\Psi_{c,N}$ Maximum anchorage depth			
	Anchor size M8	M10	M12	M16
60	0,87			
65	0,92	0,87		
70	0,97	0,92		
90	1,00	1,00	0,90	
100			0,98	0,82
125			1,00	0,97
130				1,00

#### $\Psi_{s-c,V}$ INFLUENCE OF SPACING AND EDGE DISTANCE FOR CONCRETE EDGE RESISTANCE IN SHEAR LOAD

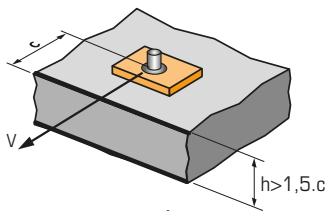

$$\Psi_{s-c,V} = \frac{c}{c_{min}} \cdot \sqrt{\frac{c}{c_{min}}}$$

##### For single anchor fastening

$\frac{c}{c_{min}}$	Reduction factor $\Psi_{s-c,V}$ Non-cracked concrete											
	1,0	1,2	1,4	1,6	1,8	2,0	2,2	2,4	2,6	2,8	3,0	3,2
$\Psi_{s-c,V}$	1,00	1,31	1,66	2,02	2,41	2,83	3,26	3,72	4,19	4,69	5,20	5,72

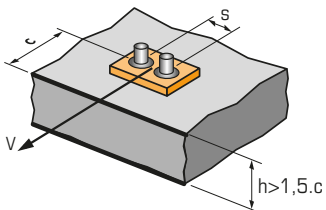

$$\Psi_{s-c,V} = \frac{3 \cdot c + s}{6 \cdot c_{min}} \cdot \sqrt{\frac{c}{c_{min}}}$$

##### For 2 anchors fastening

$\frac{s}{c_{min}}$	$\frac{c}{c_{min}}$	Reduction factor $\Psi_{s-c,V}$ Non-cracked concrete											
		1,0	1,2	1,4	1,6	1,8	2,0	2,2	2,4	2,6	2,8	3,0	3,2
1,0	1,0	0,67	0,84	1,03	1,22	1,43	1,65	1,88	2,12	2,36	2,62	2,89	3,16
1,5	1,0	0,75	0,93	1,12	1,33	1,54	1,77	2,00	2,25	2,50	2,76	3,03	3,31
2,0	1,0	0,83	1,02	1,22	1,43	1,65	1,89	2,12	2,38	2,63	2,90	3,18	3,46
2,5	1,0	0,92	1,11	1,32	1,54	1,77	2,00	2,25	2,50	2,77	3,04	3,32	3,61
3,0	1,0	1,00	1,20	1,42	1,64	1,88	2,12	2,37	2,63	2,90	3,18	3,46	3,76
3,5			1,30	1,52	1,75	1,99	2,24	2,50	2,76	3,04	3,32	3,61	3,91
4,0				1,62	1,86	2,10	2,36	2,62	2,89	3,17	3,46	3,75	4,05
4,5					1,96	2,21	2,47	2,74	3,02	3,31	3,60	3,90	4,20
5,0						2,33	2,59	2,87	3,15	3,44	3,74	4,04	4,35
5,5							2,71	2,99	3,28	3,71	4,02	4,33	4,65
6,0							2,83	3,11	3,41	3,71	4,02	4,33	4,65

##### For 3 anchors fastening and more

$$\Psi_{s-c,V} = \frac{3 \cdot c + s_1 + s_2 + s_3 + \dots + s_{n-1}}{3 \cdot n \cdot c_{min}} \cdot \sqrt{\frac{c}{c_{min}}}$$

