

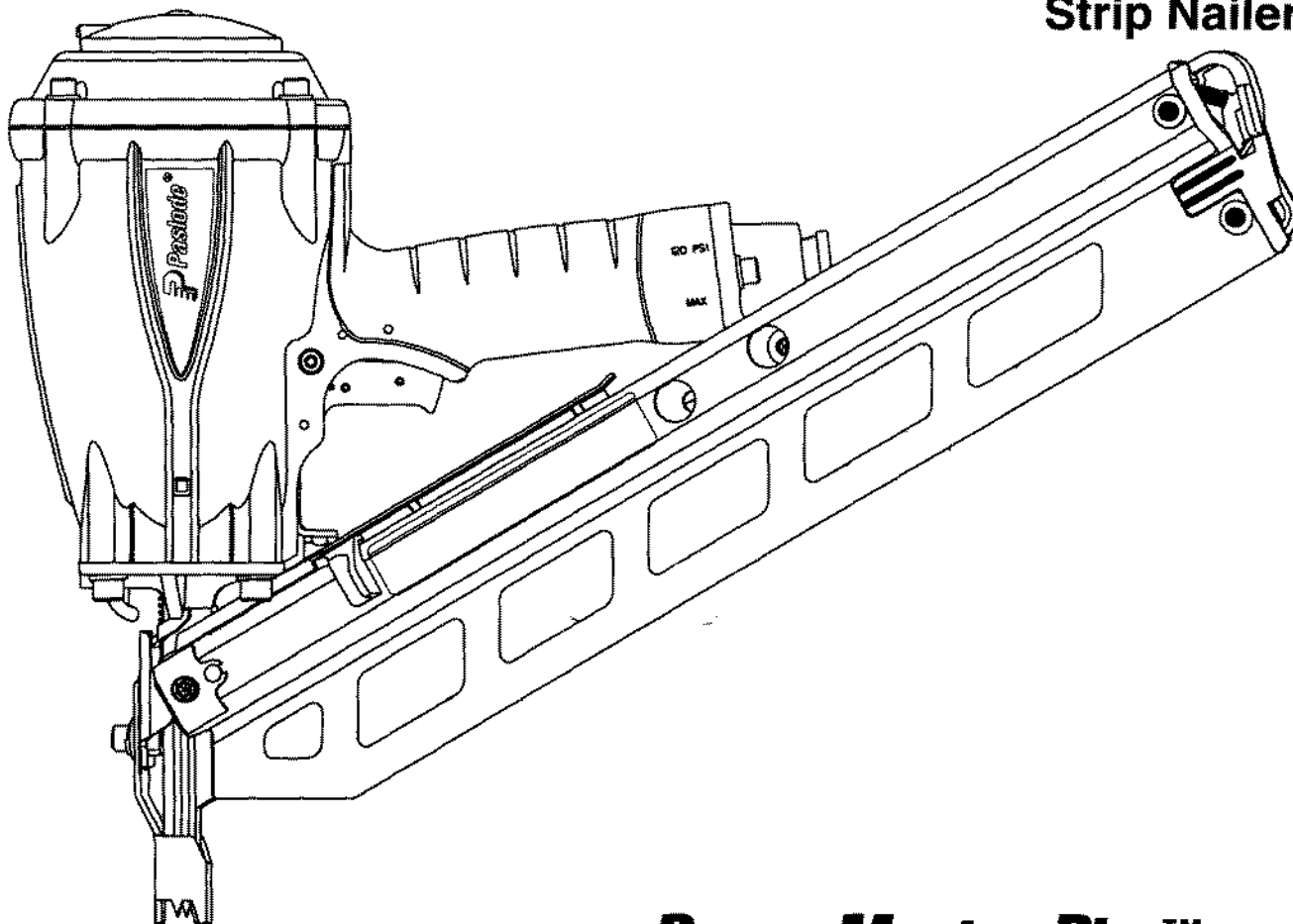

PowerMaster Plus™
MODEL PSN90
Strip Nailer



PowerMaster Plus™

IMPORTANT!
DO NOT DESTROY

Always refer to safety and maintenance manual #405218 and #405219 for detailed information on this tool. It is the customers responsibility to have all operators and service personnel read and understand this information.

**TOOL SCHEMATIC AND
PARTS**

PARTS LEGEND *PowerMaster Plus*™ PSN90, 501560

▲ 1	501043	1	T.H.S.C.S. 1/4 -20 x 1/2"	39	402668	1	Retaining Ring
2	501016	1	Air Deflector	40	097748	1	Spring, Valve Pin
3	501300	4	S.H.C.S. 1/4-20 x 1-1/4"	41	097746	1	Valve Pin
4	500249	1	O-Ring, Sleeve	42	071297	3	Roll Pin 1/8 x 1-1/8"
5	501017	1	Cap	*43	092174	1	O-Ring, Valve Body
*6	500461	1	O-Ring	44	401958	1	Valve Body
*7	092042	2	O-Ring	45	501039	1	Sequential Trigger
8	500407	1	Spring, Main Valve	46	501052	1	Nose 30°
*9	501001	1	Gasket, Cap	47	095417	4	Lockwasher 5/16
10	406041	1	Retaining Ring	▲48	009016	4	S.H.C.S. 5/16-18 x 1"
11	500455	1	Upper Valve Piston	49	501006	1	Spring, W.C.E.
12	401946	1	Seal, Main Valve	50	501363	1	Upper W.C.E.
*13	091208	1	O-Ring	51	404800	1	Washer, W.C.E.
*14	401950	1	O-Ring	52	500731	1	Lower W.C.E.
15	500456	1	Lower Valve Piston	53	002187	1	Lock Washer
16	500454	1	Post	54	500717	1	Nail Cover
*17	095432	1	O-Ring	55	500531	1	Follower
18	500453	1	Bumper, Post	56	501044	1	3/16 Hex Key, Long Arm
19	402906	1	B.H.S.C.S. 10-32 x 5/8"	57	501024	1	End Cap, Magazine-LF
*20	092971	1	O-Ring, Piston	58	501025	1	End Cap, Magazine-RT
■*21	501218	1	Driver Blade	59	501027	1	Latch
22	402011	1	Seal Sleeve	60	501046	1	Drum Pin Assembly
23	501283	1	Sleeve	61	500513	1	Negator Assembly
*24	092235	1	O-Ring, Sleeve	62	501524	1	Nameplate
*25	501002	1	O-Ring	▲63	404904	2	Screw 1/4-28 x 5/8"
*26	500866	1	Bumper	64	500509	1	Front Bracket
27	501286	1	Housing	65	501028	1	Spring, Latch
28	500779	1	Flange, Sleeve	66	501026	1	S.H.C.S. 8-32 x 2"
29	501333	1	Label, Housing-Left	67	066840	1	S.H.C.S. 8-32 x 3/4"
	501334	1	Label, Housing -Right	68	404414	2	Flatwasher #8
30	501219	1	End Cap, Housing	69	404325	2	Stop Nut
31	500516	1	B.H.S.C.S. - Special	70	500520	2	Wear Strip
32	404274	1	Flat Washer	**71	500458	1	Warning Label
33	500525	1	Locknut, 5/16-24	72	501055	1	Logo Label
34	091622	1	Reducing Pipe Bushing	74	500729	1	Blade Seal
35	501010	1	Bump Trigger	75	501337	1	Piston
36	402669	1	Pin, Trigger	76	091618	1	S.H.C.S. 1/4-20 x 1/2"
37	501009	1	Spirol Pin	77	501299	2	S.H.C.S. 1/4-20 x 1"
38	501008	1	Lever, Bottom Trip				

* Denotes Normal Wear Items

** Make sure Warning Label (Part No. 500458) is properly affixed. Replace if necessary. Label available at no charge through the Service Department.

▲ Apply Loctite 242 (Blue) Part No. 093500

■ Apply Loctite Green Part No. 401491

→ Denotes New Change



WARNING

All parts must be periodically inspected and replaced if worn or broken. Failure to do this can affect the tool's operation and present a safety hazard.

AIR CONSUMPTION CHART

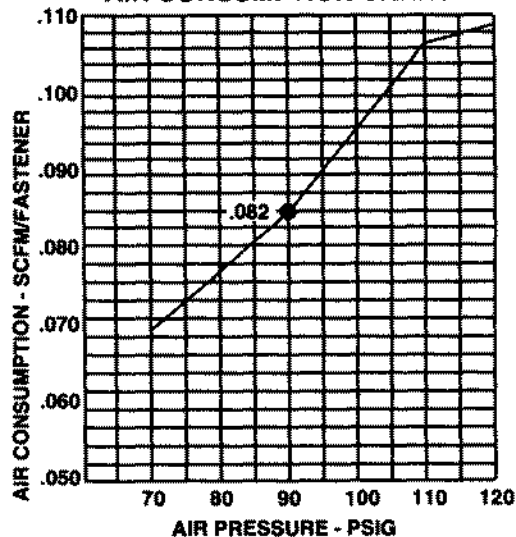

Note: For optimum performance Paslode recommends the use of a 3/8" Male fitting.

PowerMaster Plus™

PSN90
501560

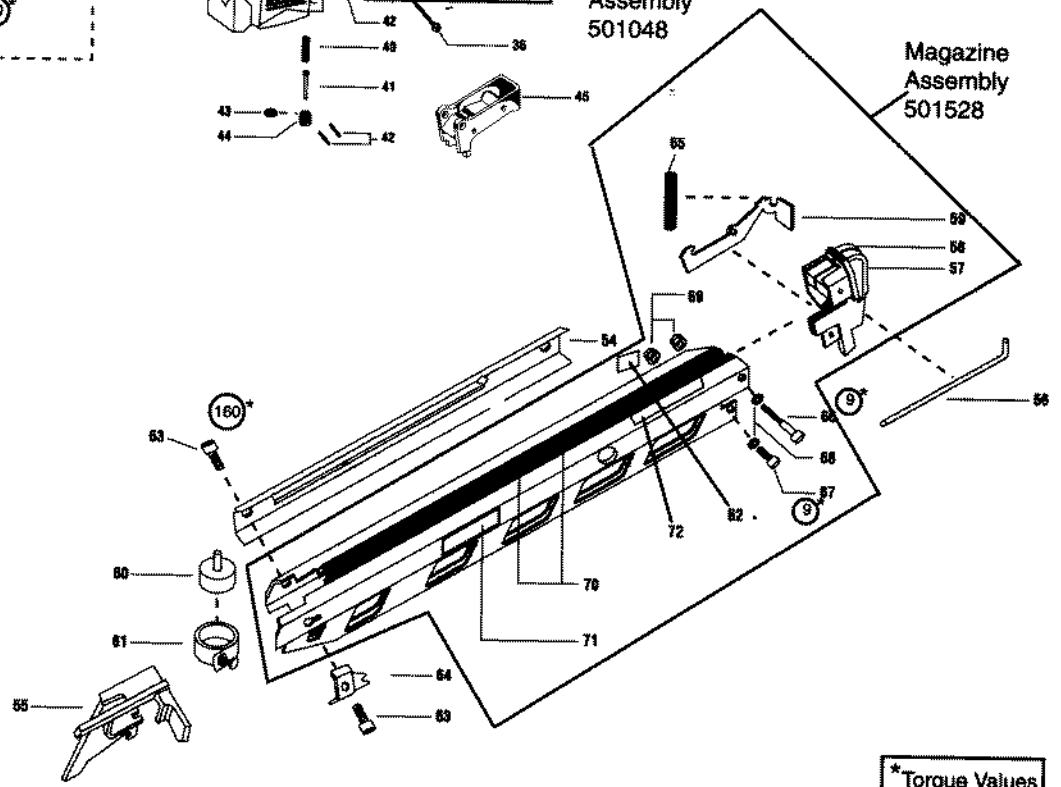
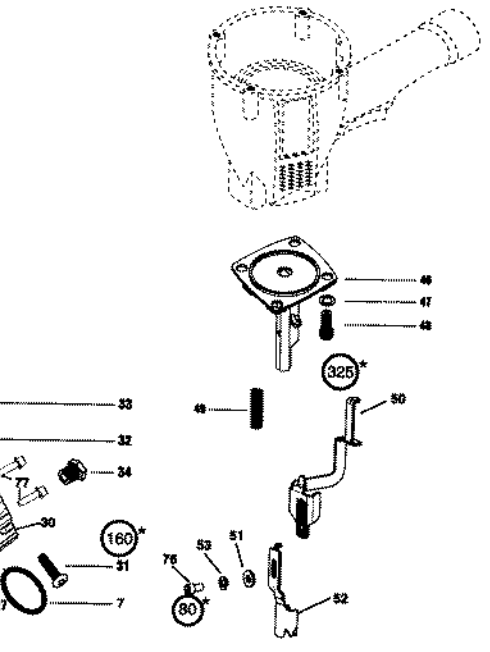
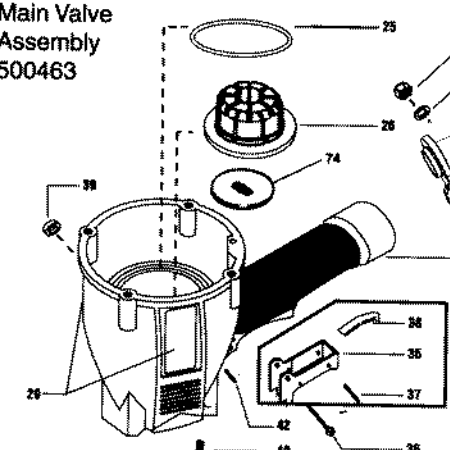
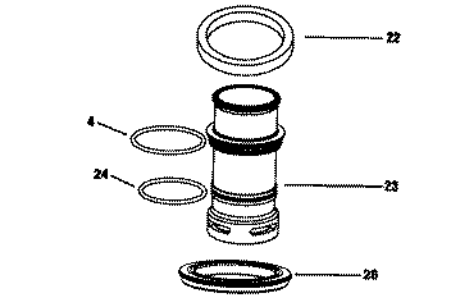
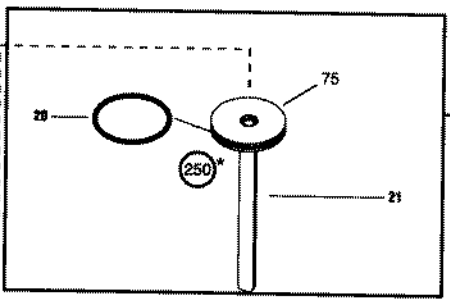
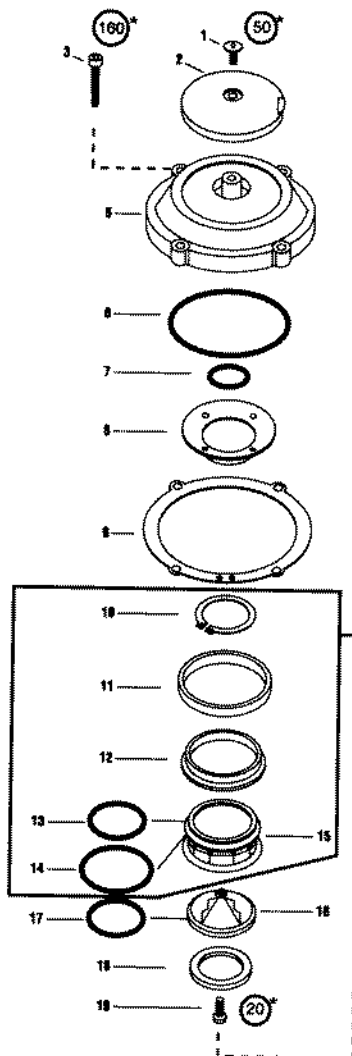

*Torque Values
IN/LBS

ACCESSORIES

Remote Fire Valve

This valve via a positive air signal allows a machine mounted tool to be operated from an automatic air valve or foot pedal system.

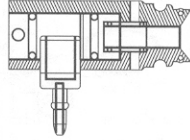

Part No. 1X0713

Adjustable No-Mar Tip Kit

Prevents you from marring wood surfaces. Kit includes an extra rubber tip. (Replacement Rubber Tip only - Part No. 501022)

Part No. 219228

Hanger Kit

Allows you to hang tool from rafters.

Part No. 501049

Cap Hanger Bracket

Attaches to the top of tool for storage or counter-balancing.

Part No. 1X0856

Tool Repair Kit

Repairs cap air leaks, lack of power, skipping and/or sluggishness.

Part No. 219235

Trigger Valve Kit

Repairs trigger valve air leaks.

Part No. 219224

Lubricants and Loctite

Loctite 242 (Blue)

Lubricating Oil 16 oz.

Lubricating Oil with Antifreeze

Chemplex 710 Lubricant 1 lb.

Lubricant 5 gram tube



Part No. 093500

Part No. 403720

Part No. 219090

Part No. 403734

Part No. 219188

Degreaser Cleaner

Ideal cleaner for all Paslode tools.

Part No. 219086

Large Nylon Tool Case

Part No. 219246

Safety Glasses

Clear

Part No. 402510

Tinted

Part No. 402512

SAFETY INSTRUCTIONS

WEAR EYE AND HEARING PROTECTION



Always wear hearing protection and eye protection devices, including side shields when operating or working in the vicinity of a tool.



Never use any bottled air or gases such as oxygen to operate the tool since they could cause the tool to explode.

DO NOT EXCEED MAXIMUM RECOMMENDED AIR PRESSURE

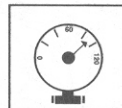
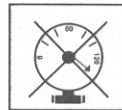

Operate the tool using only the recommended air pressure. Do not exceed the maximum air pressure marked on the tool. Be sure the air pressure gauge is operating properly and check it at least twice a day.