

ETA-Danmark A/S
Kollegievej 6
DK-2920 Charlottenlund
Tel. +45 45 76 20 20
Fax +45 45 76 33 20
Internet www.etadanmark.dk



Authorised and notified according to Article 10 of the Council Directive 89/106/EEC of 21 December 1988 on the approximation of laws, regulations and administrative provisions of Member States relating to construction products

MEMBER OF EOTA

European Technical Approval ETA-08/0028

This ETA replaces the previous ETA with the same number and validity from 2012-12-21 to 2017-12-21

Trade name:

SIMA connectors type: Fork Anchor type 1; Rafter Anchor type 2-36, 2-48; Purlin Anchor type 170, 170-1, 210, 210-1, 250, 290, 330, 370; Purlin Anchor type 170PL, 170-1PL, 210PL, 210-1PL, 250PL, 330PL, 370PL; Rafter Connector type 180; Universal Connector type 100, 140, 190; Universal Purlin Anchor type 170, 210

Holder of approval:

Sima Industri ApS
Industrivej Nord 40
DK-7490 Aulum
Tel. +45 97 47 26 11
Fax +45 97 47 37 11
Internet www.simaindustri.dk

Generic type and use of construction product:

Three-dimensional nailing plate (connectors for wood to wood connections)

Valid from:
to:

2013-06-26
2017-12-21

Manufacturing plant:

Sima Industri ApS
Industrivej Nord 40
DK-7490 Aulum

This European Technical Approval contains:

31 pages including 3 annexes which form an integral part of the document



European Organisation for Technical Approvals

Europæisk Organisation for Tekniske Godkendelser

I LEGAL BASIS AND GENERAL CONDITIONS

1 This European Technical Approval is issued by ETA-Danmark A/S in accordance with:

- Council Directive 89/106/EEC of 21 December 1988 on the approximation of laws, regulations and administrative provisions of Member States relating to construction products¹⁾, as amended by Council Directive 93/68/EEC of 22 July 1993²⁾.
- Bekendtgørelse 559 af 27-06-1994 (afløser bekendtgørelse 480 af 25-06-1991) om ikrafttræden af EF direktiv af 21. december 1988 om indbyrdes tilnærmelse af medlemsstaternes love og administrative bestemmelser om byggevarer.
- Common Procedural Rules for Requesting, Preparing and the Granting of European Technical Approvals set out in the Annex to Commission Decision 94/23/EC³⁾.
- EOTA Guideline ETAG 015 *Three-dimensional nailing plates*, September 2002 edition.

2 ETA-Danmark A/S is authorized to check whether the provisions of this European Technical Approval are met. Checking may take place in the manufacturing plant. Nevertheless, the responsibility for the conformity of the products to the European Technical Approval and for their fitness for the intended use remains with the holder of the European Technical Approval.

3 This European Technical Approval is not to be transferred to manufacturers or agents of manufacturers other than those indicated on page 1, or manufacturing plants other than those indicated on page 1 of this European Technical Approval.

4 This European Technical Approval may be withdrawn by ETA-Danmark A/S pursuant to Article 5(1) of Council Directive 89/106/EEC.

1) Official Journal of the European Communities N° L40, 11 Feb 1989, p 12.

2) Official Journal of the European Communities N° L220, 30 Aug 1993, p 1.

3) Official Journal of the European Communities N° L 17, 20 Jan 1994, p 34.

5 Reproduction of this European Technical Approval including transmission by electronic means shall be in full. However, partial reproduction can be made with the written consent of ETA-Danmark A/S. In this case partial reproduction has to be designated as such. Texts and drawings of advertising brochures shall not contradict or misuse the European Technical Approval.

6 This European Technical Approval is issued by ETA-Danmark A/S in English. This version corresponds fully to the version circulated within EOTA. Translations into other languages have to be designated as such.

II SPECIAL CONDITIONS OF THE EUROPEAN TECHNICAL APPROVAL

1 Definition of product and intended use

Definition of the product

SIMA Industri connectors type Fork Anchor type 1; Rafter Anchor type 2-36, 2-48; Purlin Anchor type 170, 170-1, 210, 210-1, 250, 290, 330, 370; Purlin Anchor type 170PL, 170-1PL, 210PL, 210-1PL, 250PL, 290PL, 330PL, 370PL; Rafter Connector type 180; Universal Connector type 100, 140, 190; Universal Purlin Anchor type 170, 210 are one-piece, non-welded anchor connectors. They are intended for timber-to-timber bracket connections fastened with specified nails.

Most of the brackets are made from pre-galvanized steel Grade S250GD + min. Z275 according to EN 10346. Dimensions, hole positions, steel type and typical installations are shown in Annex B. Additionally, the purlin anchors *PL can be made from 1,5 mm pre-galvanized steel in grades from Grade S350GD to S500GD + min. Z275 according to EN 10346.

Intended use

The brackets are intended for use in making side-grain to side-grain connections in load bearing timber structures, as a connection between a wood based purlin and a solid timber or wood based beam, where requirements for mechanical resistance and stability and safety in use in the sense of the Essential Requirements 1 and 4 of Council Directive 89/106/EEC shall be fulfilled.

The brackets can be installed as connections between wood based members such as:

- Structural solid timber classified to C14-C40 according to EN 338 / EN 14081,
- Glulam classified to GL24-GL36 according to EN 1194 / EN 14080,
- LVL according to EN 14374,
- Parallam PSL,
- Intrallam LSL,
- Duo- and Triobalken,
- Layered wood plates,
- Kreuzbalken with minimum thickness of 80 mm
- I-beams with backer blocks on both sides of the web in the header and web stiffeners in the joist
- Plywood according to EN 636

However, the calculation methods are only allowed for a characteristic wood density of up to 350 kg/m³. Even though the wood based material may have a larger density, this must not be used in the formulas for the load-carrying capacities of the fasteners.

Annex C give the tables for the characteristic load-

carrying capacities of the bracket connections.

For timber or wood based material with a lower characteristic density than 350 kg/m³ the load-carrying capacities shall be reduced by the k_{dens} factor:

$$k_{dens} = \left(\frac{\rho_k}{350} \right)^2$$

Where ρ_k is the characteristic density of the timber in kg/m³.

The design of the connections shall be in accordance with Eurocode 5 or a similar national Timber Code.

It is assumed that the force acting on the bracket connection is F_1 as shown in the figure below. The force shall act in the middle of the purlin.

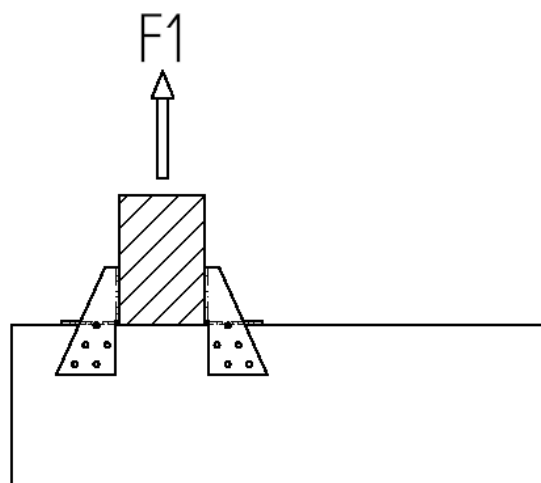

It is assumed that the beam is prevented from rotating. The brackets are intended for use for connections subject to static or quasi static loading.

The zinc-coated hangers are for use in timber structures subject to dry, internal conditions defined by the service classes 1 and 2 of EN 1995-1-1, (Eurocode 5).

Assumed working life

The assumed intended working life of the brackets for the intended use is 50 years, provided that they are subject to appropriate use and maintenance.

The information on the working life should not be regarded as a guarantee provided by the manufacturer or ETA-Danmark A/S. An “assumed intended working life” means that it is expected that, when this working life has elapsed, the real working life may be, in normal use conditions, considerably longer without major degradation affecting the essential requirements.

2 Characteristics of product and assessment

ETAG para.	Characteristic	Assessment of characteristic
2.1 Mechanical resistance and stability*)		
6.1.1	Characteristic load-carrying capacity	See Annex C
6.1.2	Stiffness	No performance determined
6.1.3	Ductility in cyclic testing	No performance determined
2.2 Safety in case of fire		
6.2.1	Reaction to fire	The anchor connectors are made from steel classified as Euroclass A1 in accordance with EN 13501-1 and EC decision 96/603/EC, amended by EC Decision 2000/605/EC
2.3 Hygiene, health and the environment		
6.3.1	Influence on air quality	No dangerous materials **)
2.4 Safety in use		
Not relevant		
2.5 Protection against noise		
Not relevant		
2.6 Energy economy and heat retention		
Not relevant		
2.7 Related aspects of serviceability		
6.7.1	Durability	The brackets have been assessed as having satisfactory durability and serviceability when used in timber structures using the timber species described in Eurocode 5 and subject to the conditions defined by service class 1 and 2
6.7.2	Serviceability	
6.7.3	Identification	

*) See page 5 of this ETA

**) In accordance with <http://europa.eu.int/-/comm/enterprise/construction/internal/dangsub/dangmain.htm> In addition to the specific clauses relating to dangerous substances contained in this European Technical Approval, there may be other requirements applicable to the products falling within its scope (e.g. transposed European legislation and national laws, regulations and administrative provisions). In order to meet the provisions of the EU Construction Products Directive, these requirements need also to be complied with, when and where they apply.

Safety principles and partial factors

The characteristic load-carrying capacities have been calculated without considering different ratios between the partial factors for timber connections and steel cross sections. Therefore, in the end use calculation based on this ETA, this shall be considered.

The values in annex C have been determined by multiplying the calculated resistance of the connection by k_{mod} to consider load duration and service classes in accordance with EC 5.

2.1 Mechanical resistance and stability

See annex C for characteristic load-carrying capacity in the direction F_1 .

The characteristic capacities of the brackets hangers are determined by calculation as described in the EOTA Guideline 015 clause 5.1.2. They should be used for designs in accordance with Eurocode 5 or a similar national Timber Code.

The design models allow the use of fasteners described in the table on page 10 in Annex B

Connector nails in accordance to ETA-09/0273

The load bearing capacities of the brackets has been determined based on the use of Paslode Connector nails 4,0 x 40 mm in accordance with the ETA-09/0273 for nails. The fastener can be replaced by fastener mentioned in the ETA-09/0273 with the same or higher performance. The capacity of the connection may not be higher than the load mentioned in this ETA.

The capacities of the nails used in calculations are:

$$F_{ax,Rk} = 0,998kN$$
$$F_{V,Rk} = 1,885kN$$

The brackets are mounted using either full or half nailing.

No performance has been determined in relation to ductility of a joint under cyclic testing. The contribution to the performance of structures in seismic zones, therefore, has not been assessed.

No performance has been determined in relation to the joint's stiffness properties - to be used for the analysis of the serviceability limit state.

2.7 Related aspects of serviceability

2.7.1 Corrosion protection in service class 1 and 2.

In accordance with ETAG 015 the anchor connectors have a zinc coating weight of min Z275. The steel employed is S250GD or S350GD with min. Z275 according to EN 10346.

3 Attestation of Conformity and CE marking

3.1 Attestation of Conformity system

The system of attestation of conformity is 2+ described in Council Directive 89/106/EEC (Construction Products Directive) Annex III.

- a) Tasks for the manufacturer:
 - (1) Factory production control,
 - (2) Initial type testing of the product,
- b) Tasks for the notified body:
 - (1) Initial inspection of the factory and the factory production control,
 - (2) Continuous surveillance

3.2 Responsibilities

3.2.1 Tasks of the manufacturer

3.2.1.1 Factory production control

The manufacturer has a factory production control system in the plant and exercises permanent internal control of production. All the elements, requirements and provisions adopted by the manufacturer are documented in a systematic manner in the form of written policies and procedures. This production control system ensures that the product is in conformity with the European Technical Approval.

The manufacturer shall only use raw materials supplied with the relevant inspection documents as laid down in the control plan¹. The incoming raw materials shall be subject to controls and tests by the manufacturer before acceptance. Check of materials, such as sheet metal, shall include control of the inspection documents presented by suppliers (comparison with nominal values) by verifying dimension and determining material properties, e.g. chemical composition, mechanical properties and zinc coating thickness.

The manufactured components are checked visually and for dimensions.

The control plan, which is part of the technical documentation of this European Technical

Approval, includes details of the extent, nature and frequency of testing and controls to be performed within the factory production control and has been agreed between the approval holder and ETA-Danmark A/S.

The results of factory production control are recorded and evaluated. The records include at least the following information:

- Designation of the product, basic material and components;
- Type of control or testing;
- Date of manufacture of the product and date of testing of the product or basic material and components;
- Result of control and testing and, if appropriate, comparison with requirements;
- Signature of person responsible for factory production control.

The records shall be presented to ETA-Danmark A/S on request

3.2.1.1 Initial type testing of the product

For initial type-testing the results of the tests performed as part of the assessment for the European Technical Approval shall be used unless there are changes in the production line or plant. In such cases the necessary initial type testing has to be agreed between ETA-Danmark A/S and the notified body

3.2.2. Tasks of notified bodies

3.2.2.1 Initial inspection of the factory and the factory production control

The approved body should ascertain that, in accordance with the control plan, the factory, in particular the staff and equipment, and the factory production control, are suitable to ensure a continuous and orderly manufacturing of the anchor connectors with the specifications given in part 2.

3.2.2.2 Continuous surveillance

The approved body shall visit the factory at least twice a year for routine inspections. It shall be verified that the system of factory production control and the specified manufacturing processes are maintained, taking account of the control plan.

The results of product certification and continuous surveillance shall be made available on demand by the certification body to ETA-Danmark A/S.

¹ The control plan has been deposited at the ETA-Danmark A/S and is only made available to the approved bodies involved in the conformity attestation procedure.

Where the provisions of the European Technical Approval and the control plan are no longer fulfilled, the certificate of conformity shall be withdrawn by the approved body.

3.3 CE marking

The CE marking shall be affixed on each packaging of anchor connectors. The initials "CE" shall be followed by the identification number of the notified body and shall be accompanied by the following information:

- Name or identifying mark of the manufacturer
- The last two digits of the year in which the marking was affixed (Production year)
- Number of the European Technical Approval
- Name and size of product
- Number of the ETA Guideline (ETAG no. 015)
- Number of the EC Certificate of Conformity

4 Assumptions under which the fitness of the product for the intended use was favourably assessed

4.1 Manufacturing

SIMA Industri connectors type Fork Anchor type 1; Rafter Anchor type 2-36, 2-48; Purlin Anchor type 170, 170-1, 210, 210-1, 250, 290, 330, 370; Purlin Anchor type 170PL, 170-1PL, 210PL, 210-1PL, 250PL, 290PL, 330PL, 370PL; Rafter Connector type 180; Universal Connector type 100, 140, 190; Universal Purlin Anchor type 170, 210 are manufactured in accordance with the provisions of this European Technical Approval using the manufacturing processes as identified in the inspection of the plant by the notified inspection body and laid down in the technical documentation.

4.2 Installation

Bracket connections

A bracket connection is deemed fit for its intended use provided:

Beam – support conditions

- The beam shall be restrained against rotation and be free from wane under the bracket.

Wood to wood connections

- The brackets can be fastened to wood-based members by nails.
- There shall be nails in all holes or a partial nailing pattern as prescribed in Annex B can be used.
- The characteristic capacity of the bracket connection is calculated according to the manufacturer's technical documentation, dated 2006-12-18.
- The bracket connection is designed in accordance with Eurocode 5 or an appropriate national code.
- The gap between the end of the purlin and the surface, where contact stresses can occur during loading shall be limited.
- The width of the purlin shall be at least the penetration length of the nails, for full nailing and partial nailing without staggering the nails in the purlin. For partial nailing with staggered nails in the purlin the width shall be at least the penetration length of the nails.
- The cross section of the purlin at the connection shall have sharp edges at the lower side against the bottom plate, i.e. it shall be without wane.

- The cross section of the beam shall have a plane surface against the whole bracket.
- The width B_p of the purlin shall correspond to that of the distance between the two brackets, B . B_p shall not be smaller than $B-3$ mm
- The depth of the purlin shall be so large that the top of the purlin is at least 20 mm above the upper nail in the purlin.
- Nails to be used shall have a diameter, which fits the holes of the brackets. Round nails shall have a diameter which is not smaller than the diameter of the hole minus 1 mm.

4.3 Maintenance and repair

Maintenance is not required during the assumed intended working life.

Should repair prove necessary, it is normal to replace the bracket.



Thomas Bruun
Manager, ETA-Danmark

Annex A
Changes from last ETA

Additions and modifications for this ETA	
Pages	Update
9	Annex A added
13-16 and 23-27	Purlin Anchor type 170PL, 170-1PL, 210PL, 210-1PL, 250PL, 290PL, 330PL, 370PL added
11-19	Colored hole patterns

Additions and modifications for the ETA valid from 2012-12-21 to 2017-12-21	
Pages	Update
	ETA extended 5 years
21-31	Revision of all values due to new Paslode Connector nails
11 and 22	Rafter Anchor type 2-36 and 2-48 added

Annex B
Product details and definitions

Table A1 Fastener specification

Nail and screw type	Nail and screw size (mm)		Finish	ETA
	Diameter	Length		
Paslode Connector nail	4,0	40	Electroplated zinc	09/0273

Connector specification:

Holes marked in blue are used in case of partial nailing

Holes marked with green and blue are used in case of optimal nailing

Purlin anchors and trim fix are marked with numbers referenced from Annex C

Fork anchor 1

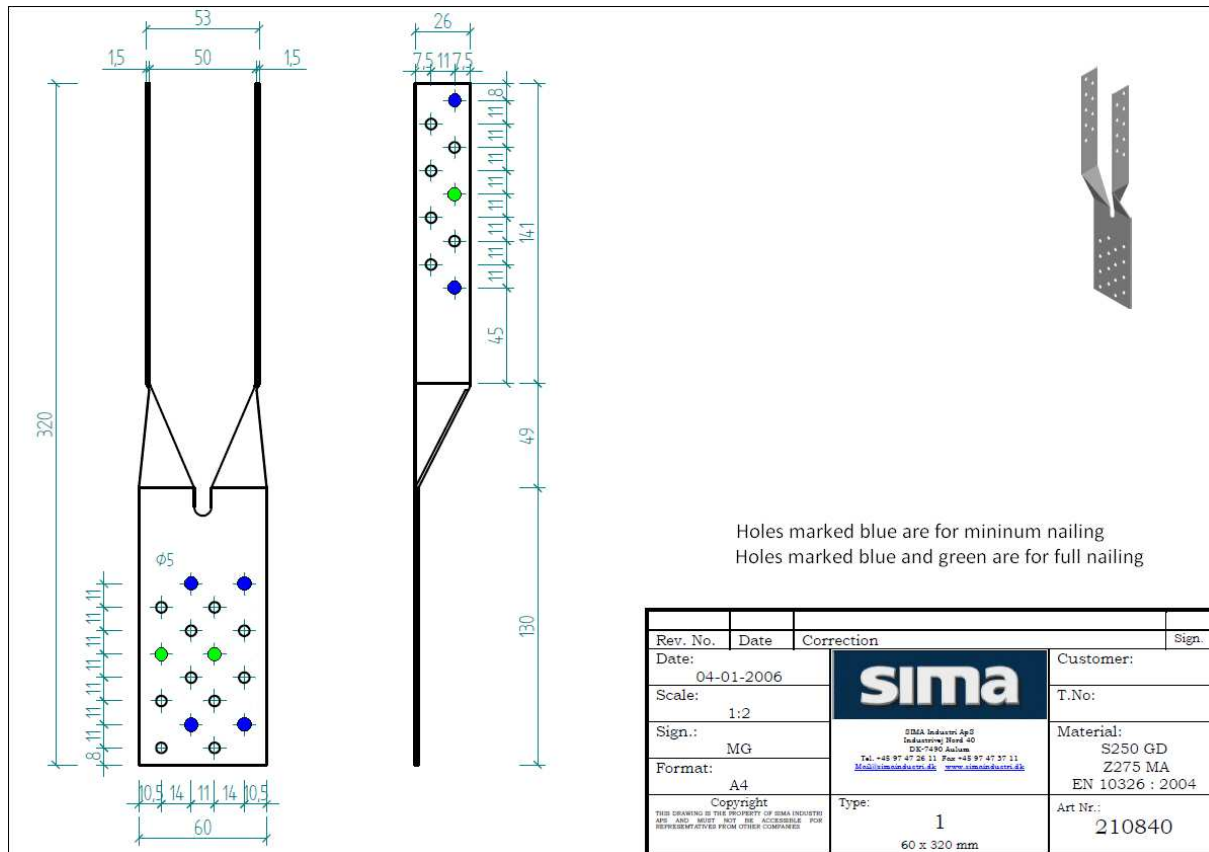

Rafter anchor type 2-36

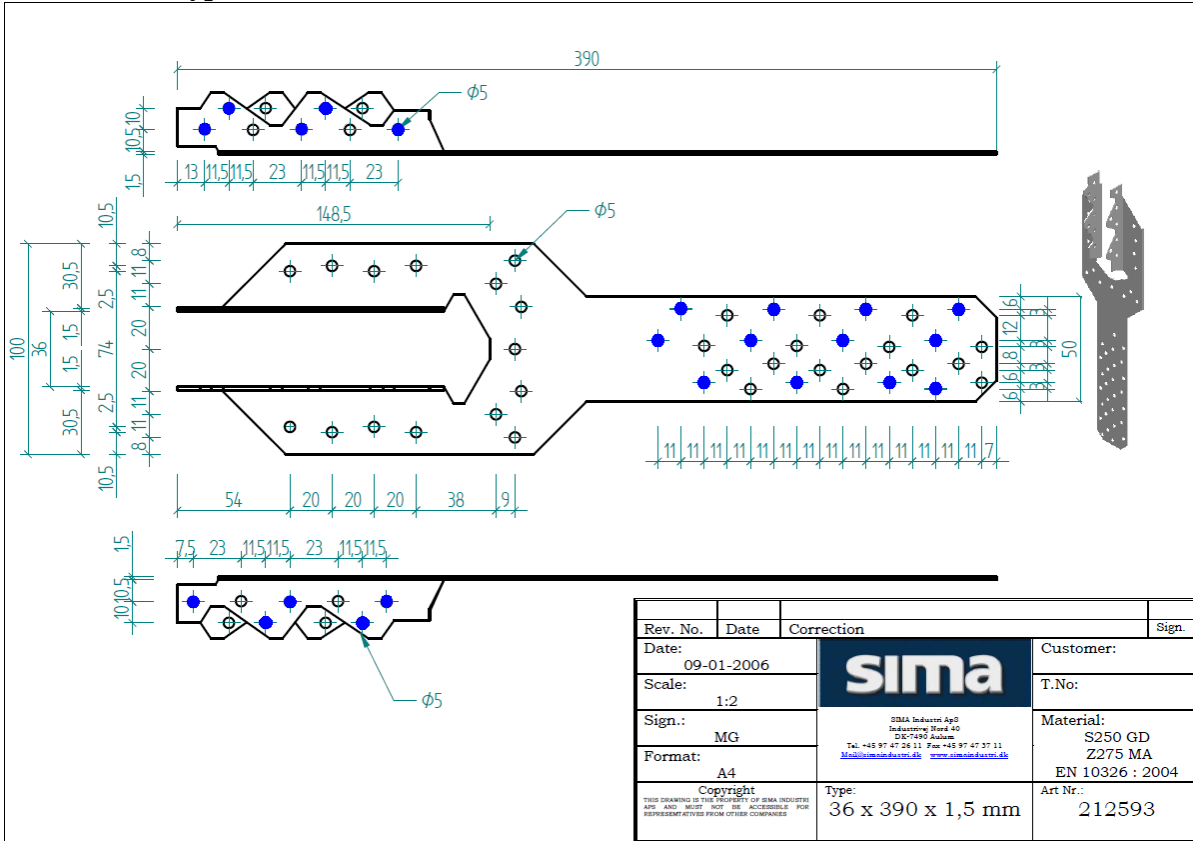

Rafter anchor type 2-48

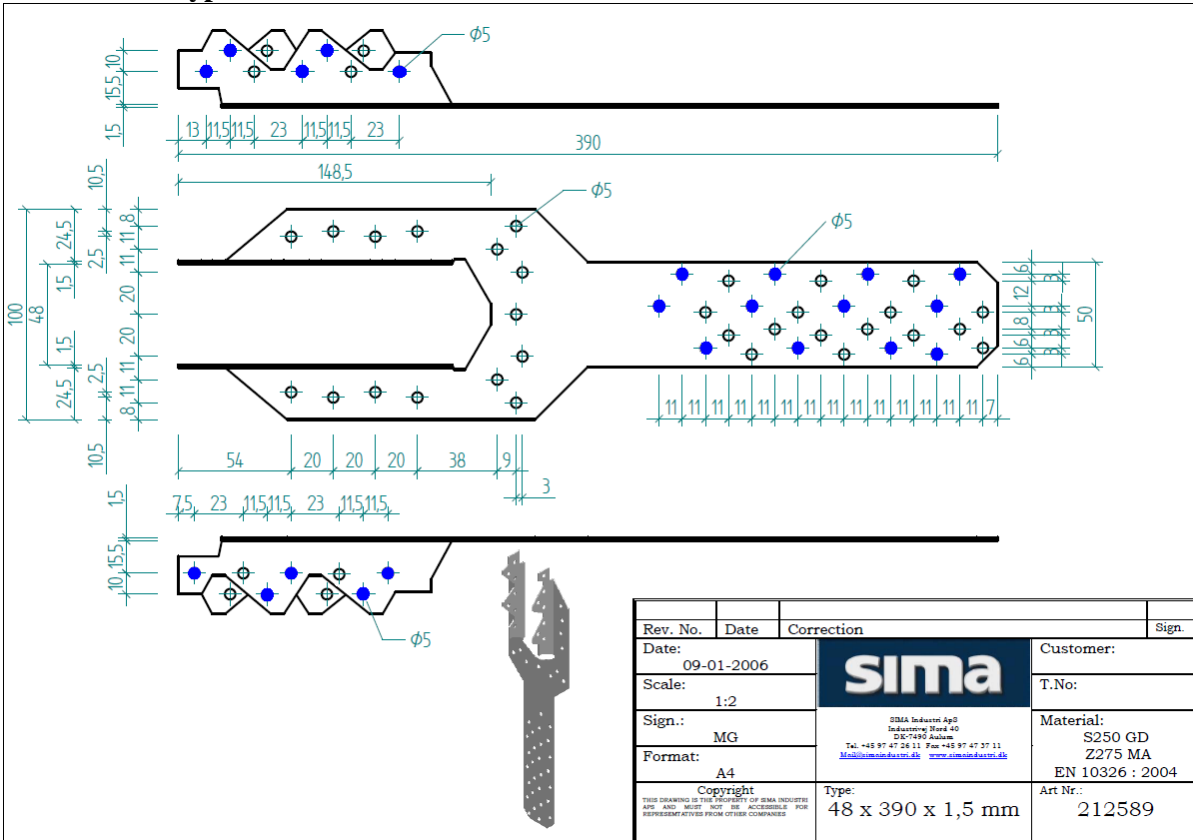

Purlin anchor 170

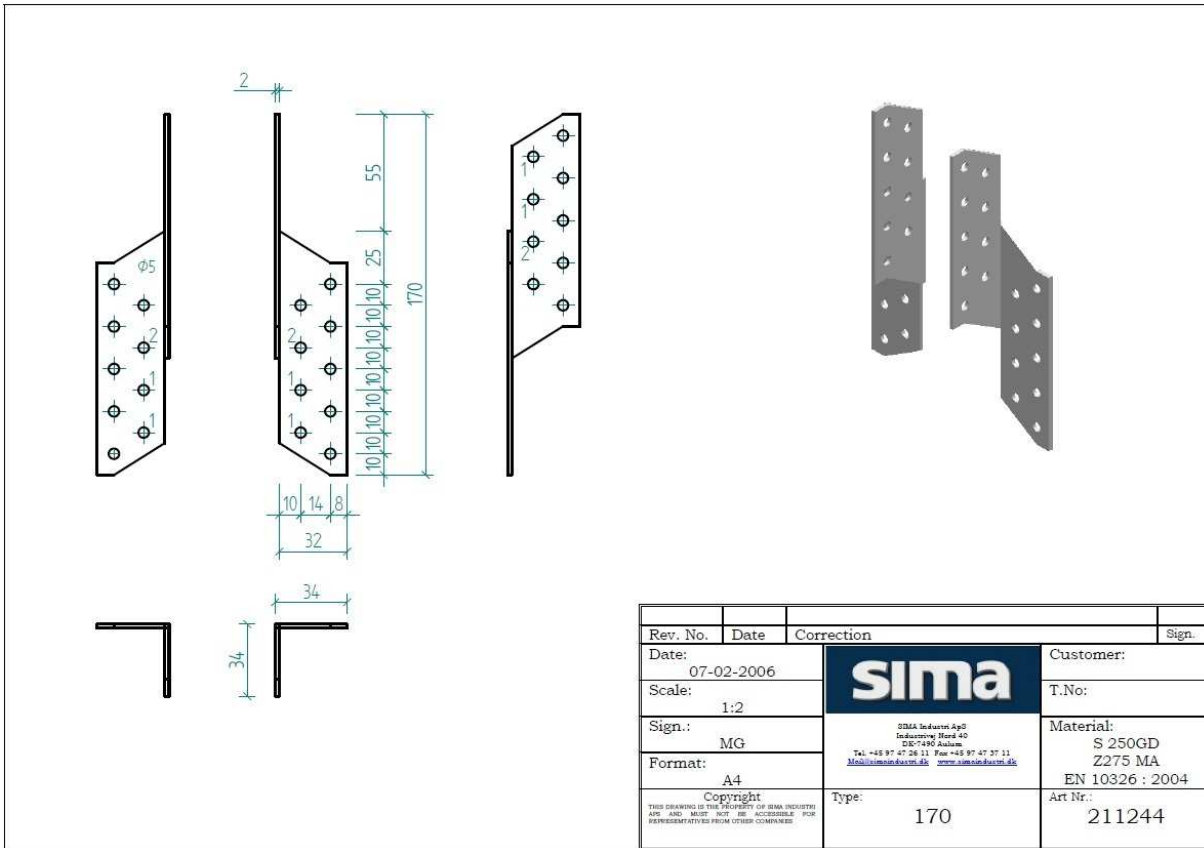

Additionally the bracket can be made from 1,5 mm pre-galvanized steel grades S350GD to Grade S500GD + min. Z275 according to EN 10346 named Purlin Anchor 170PL

Purlin anchor 170-1

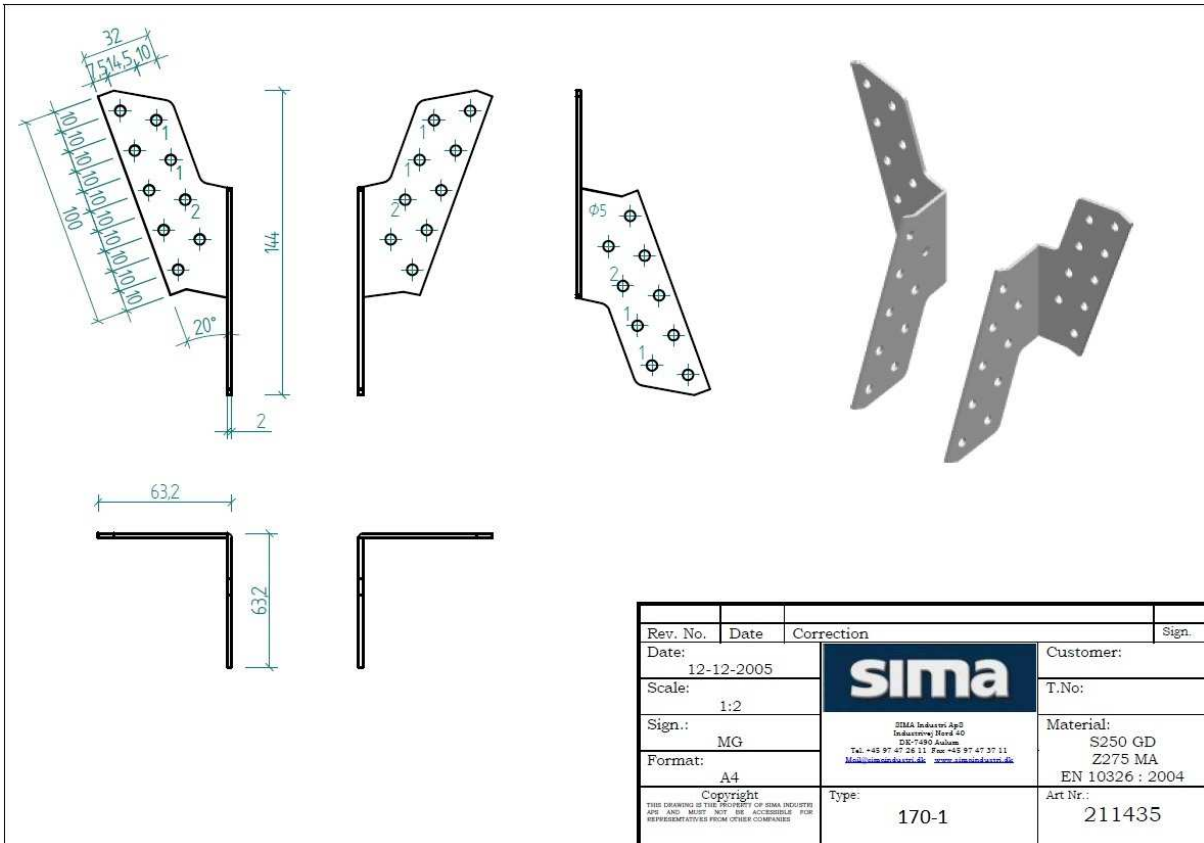

Additionally the bracket can be made from 1,5 mm pre-galvanized steel grades S350GD to Grade S500GD + min. Z275 according to EN 10346 named Purlin Anchor 170-1PL

Purlin anchor 210

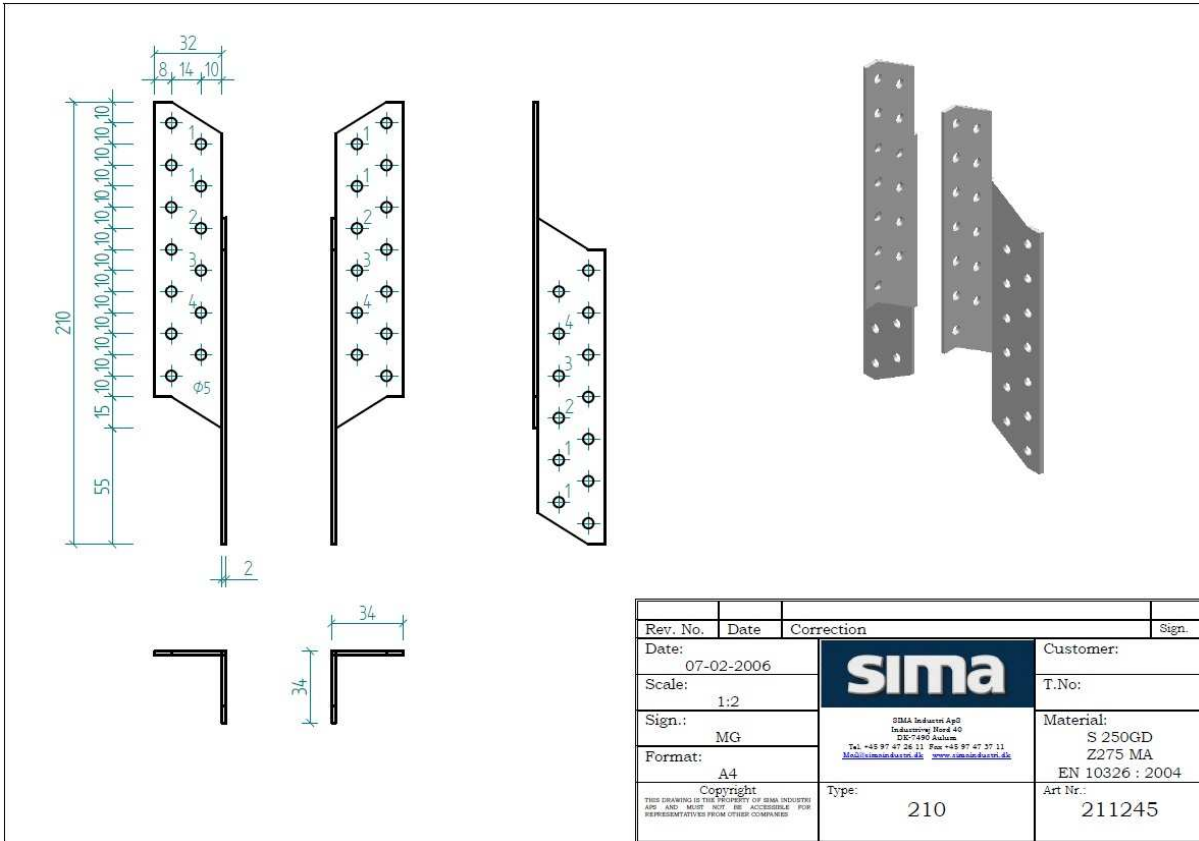

Additionally the bracket can be made from 1,5 mm pre-galvanized steel grades S350GD to Grade S500GD + min. Z275 according to EN 10346 named Purlin Anchor 210PL

Purlin anchor 210-1

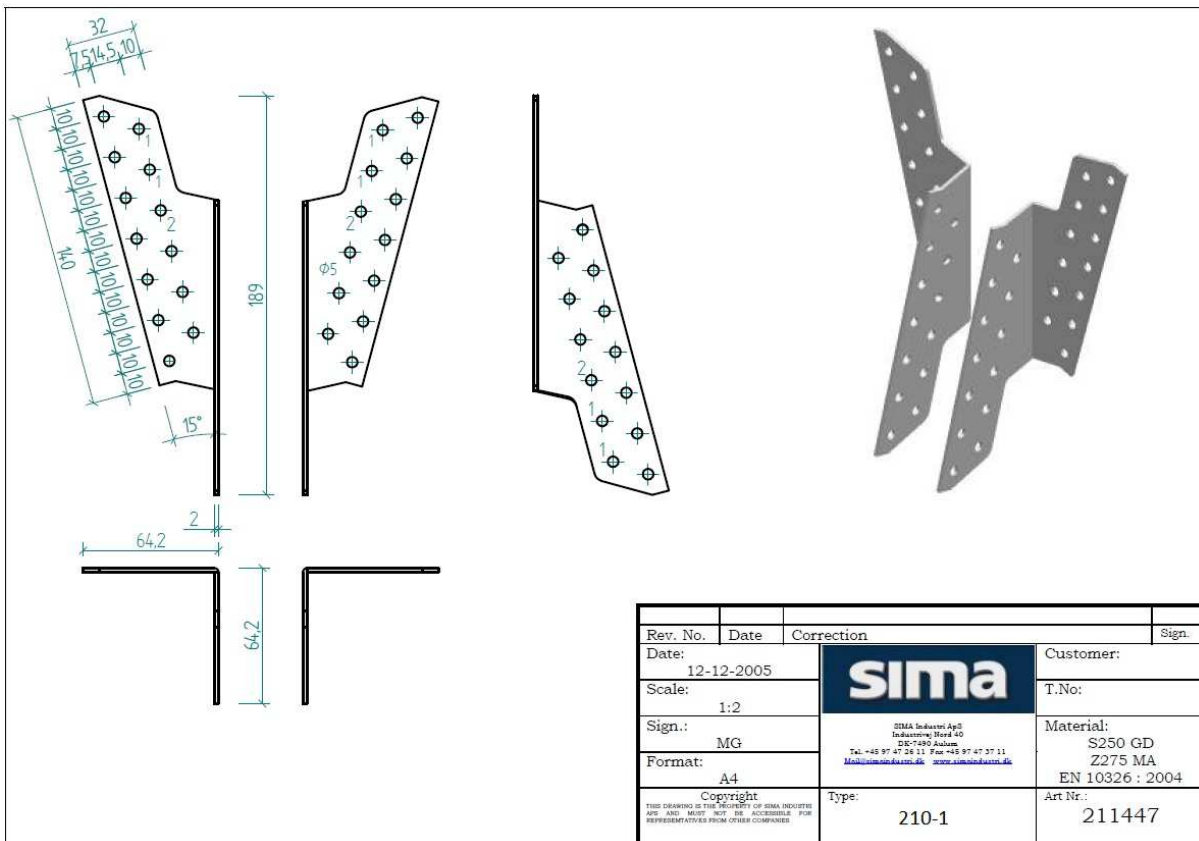

Additionally the bracket can be made from 1,5 mm pre-galvanized steel grades S350GD to Grade S500GD + min. Z275 according to EN 10346 named Purlin Anchor 210-1PL

Purlin anchor 250

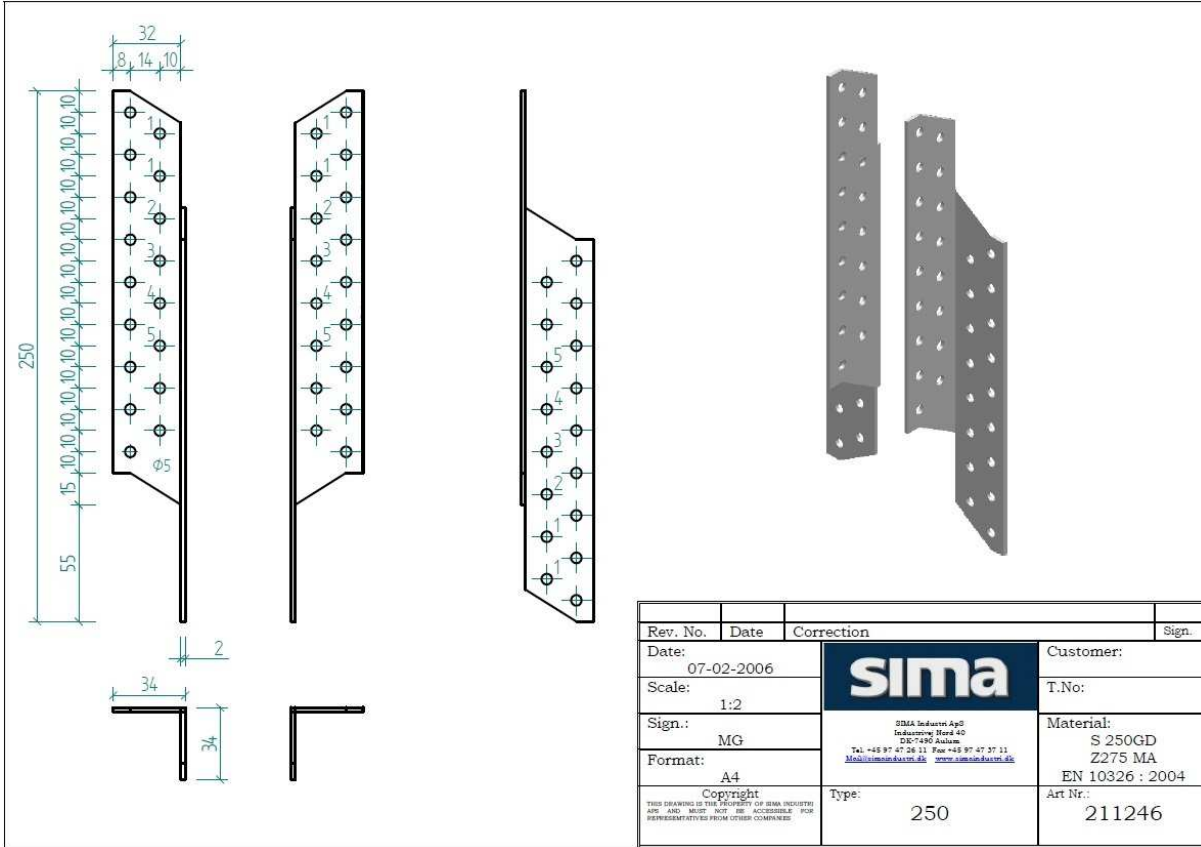

Additionally the bracket can be made from 1,5 mm pre-galvanized steel grades S350GD to Grade S500GD + min. Z275 according to EN 10346 named Purlin Anchor 250PL

Purlin anchor 290

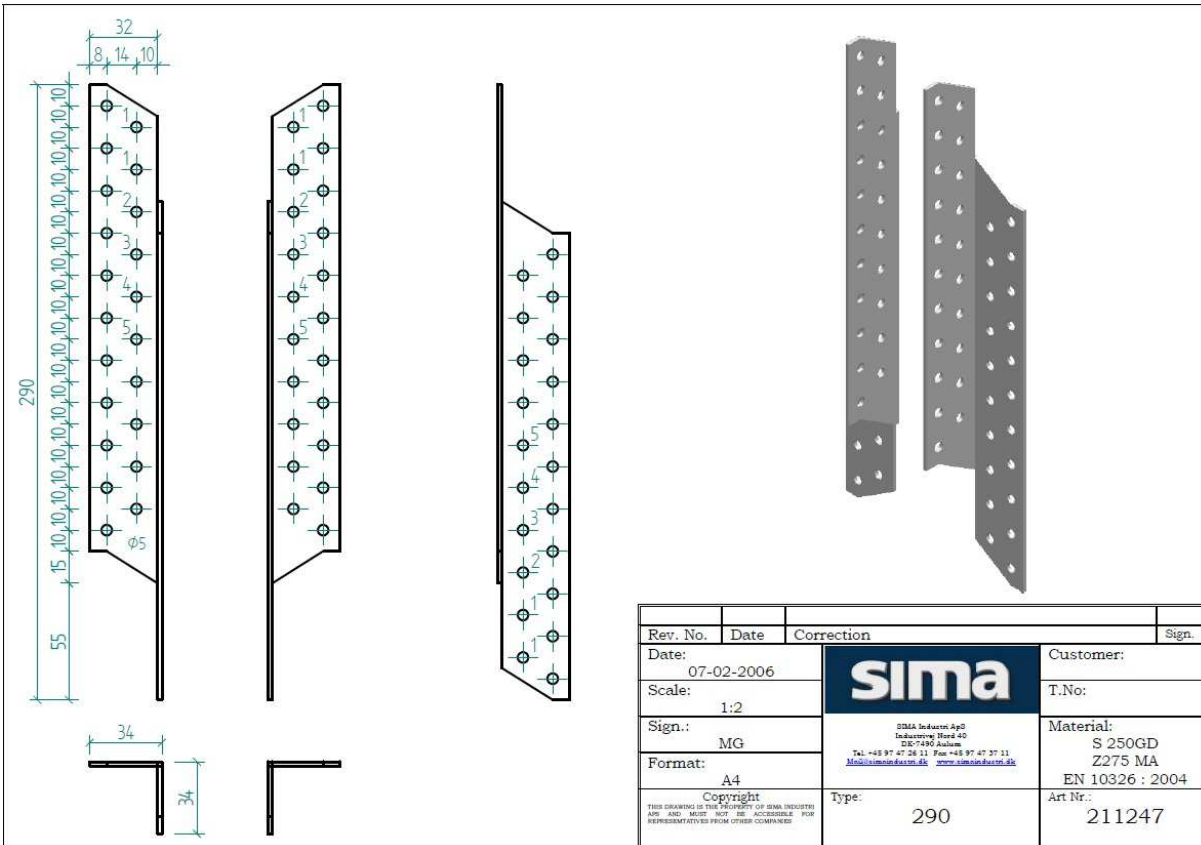

Additionally the bracket can be made from 1,5 mm pre-galvanized steel grades S350GD to Grade S500GD + min. Z275 according to EN 10346 named Purlin Anchor 290PL

Purlin anchor 330

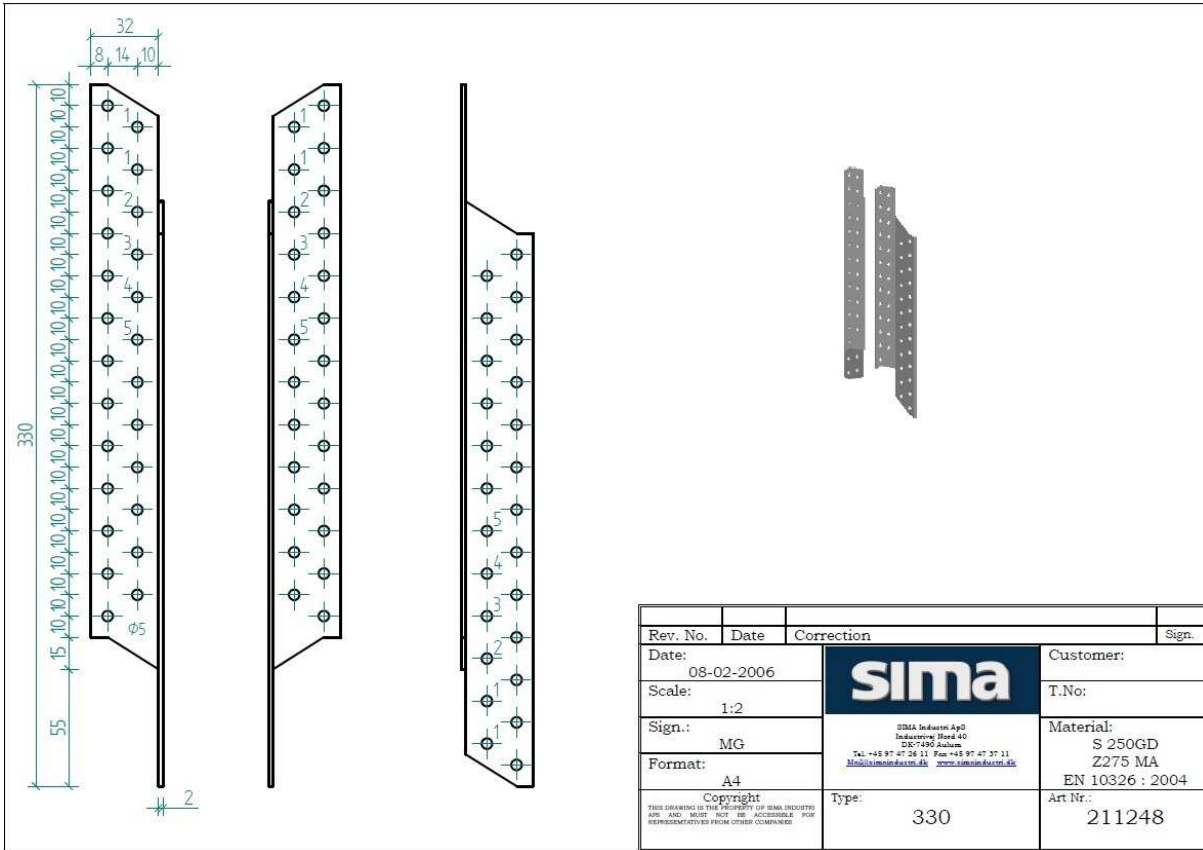

Additionally the bracket can be made from 1,5 mm pre-galvanized steel grades S350GD to Grade S500GD + min. Z275 according to EN 10346 named Purlin Anchor 330PL

Purlin anchor 370

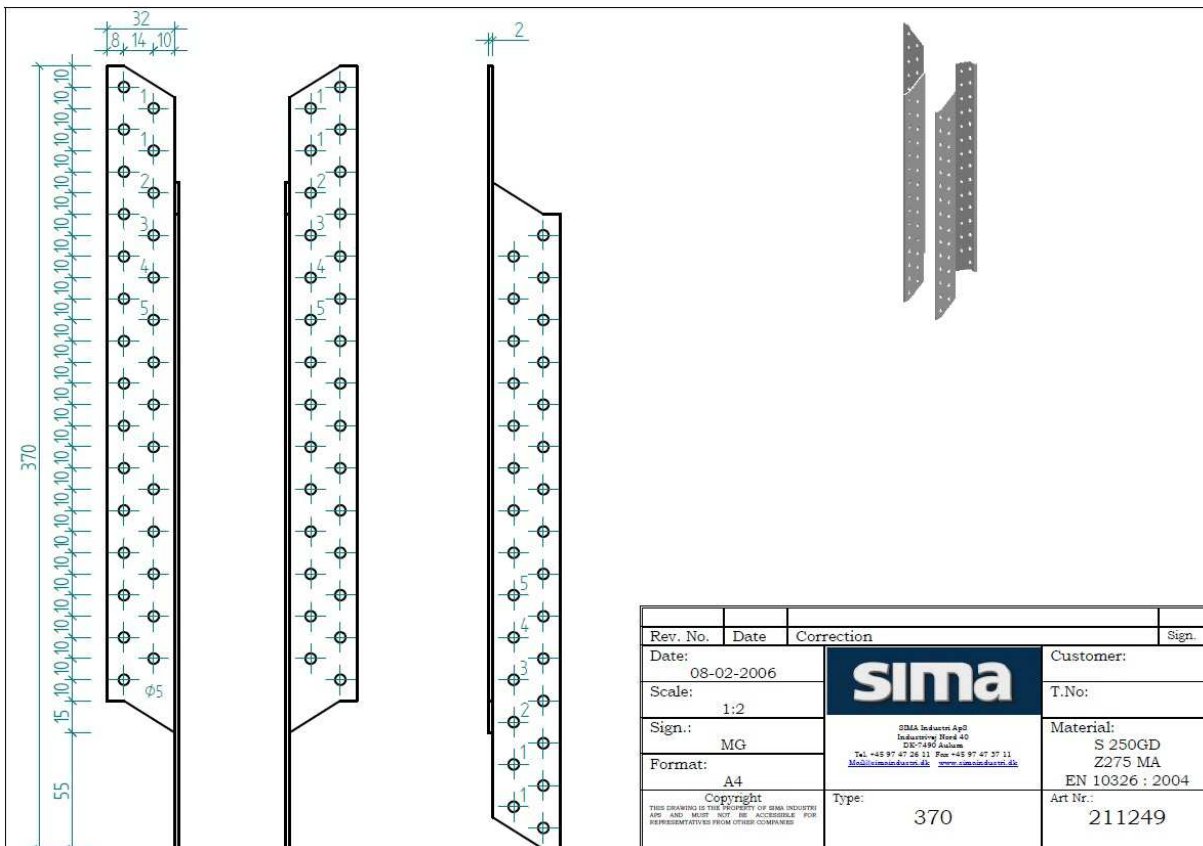

Additionally the bracket can be made from 1,5 mm pre-galvanized steel grades S350GD to Grade S500GD + min. Z275 according to EN 10346 named Purlin Anchor 370PL

Rafter connector 180

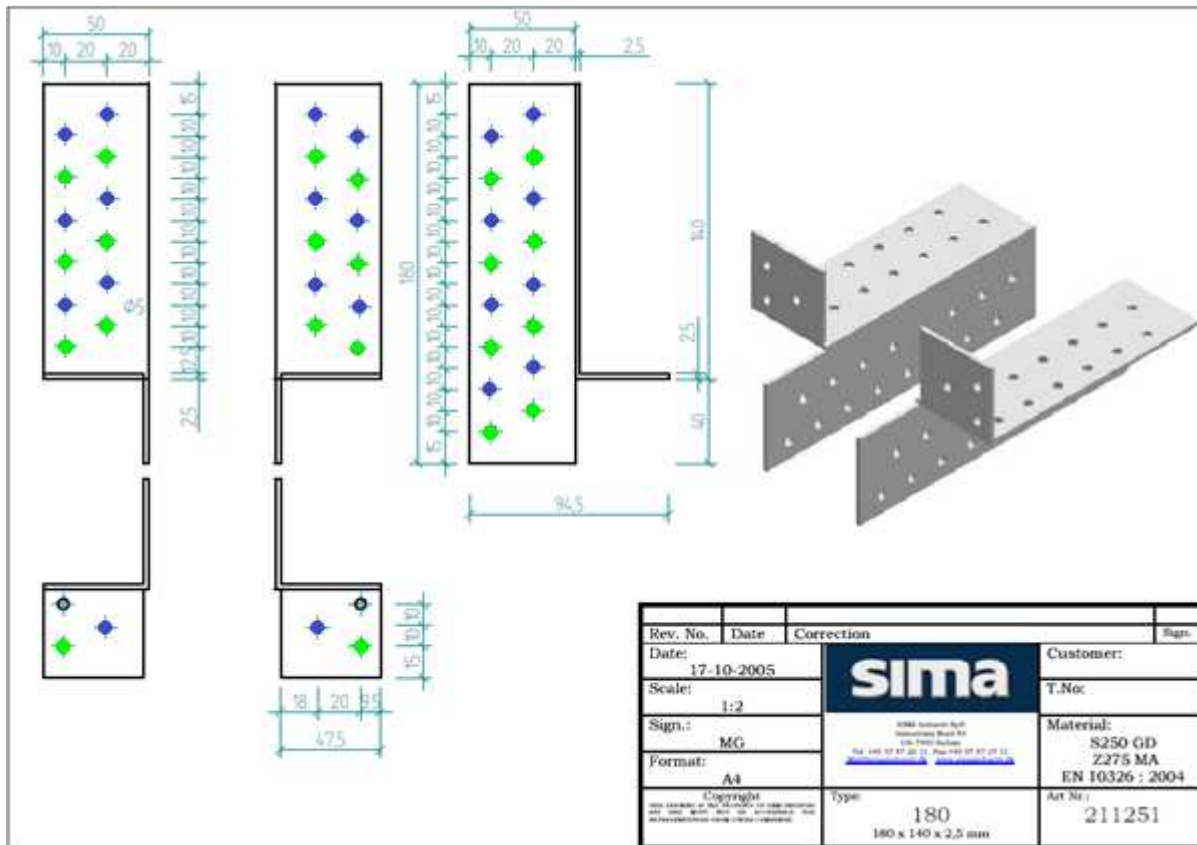

Universal connector 100

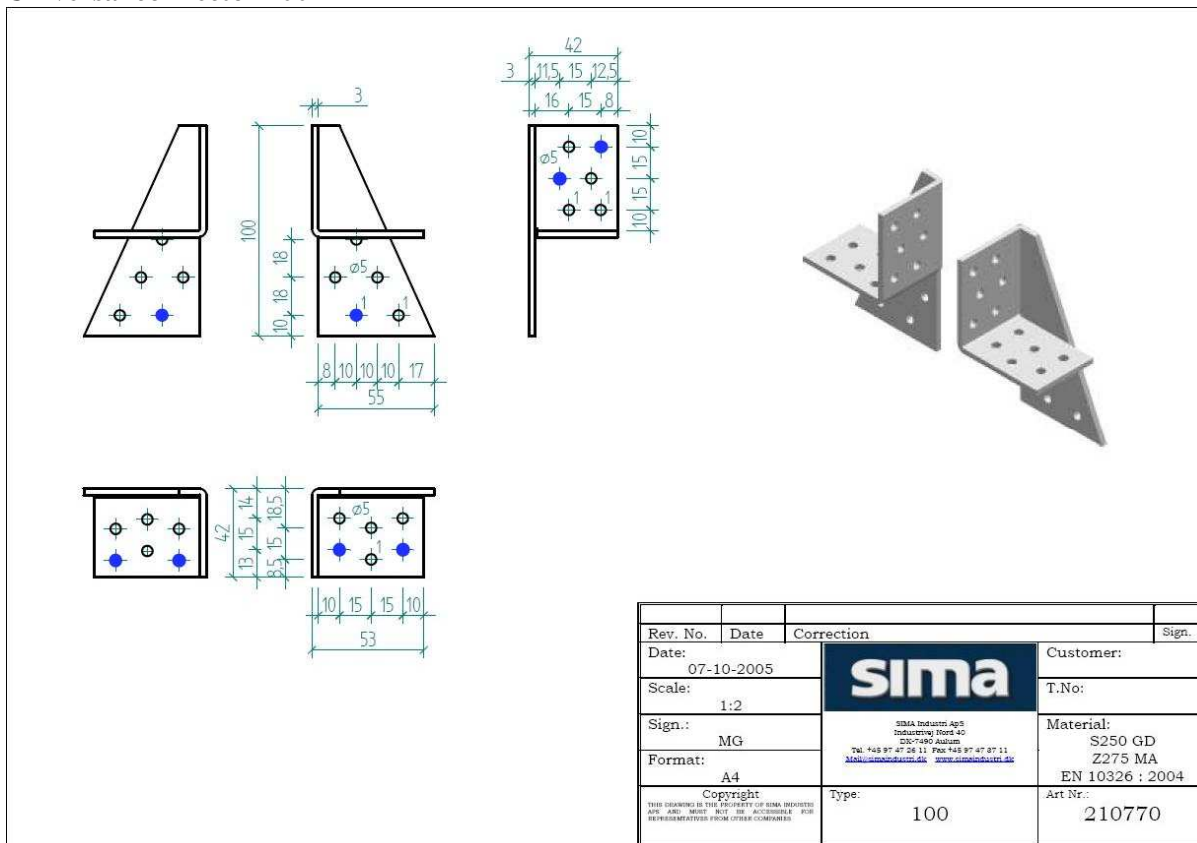

Universal connector 140

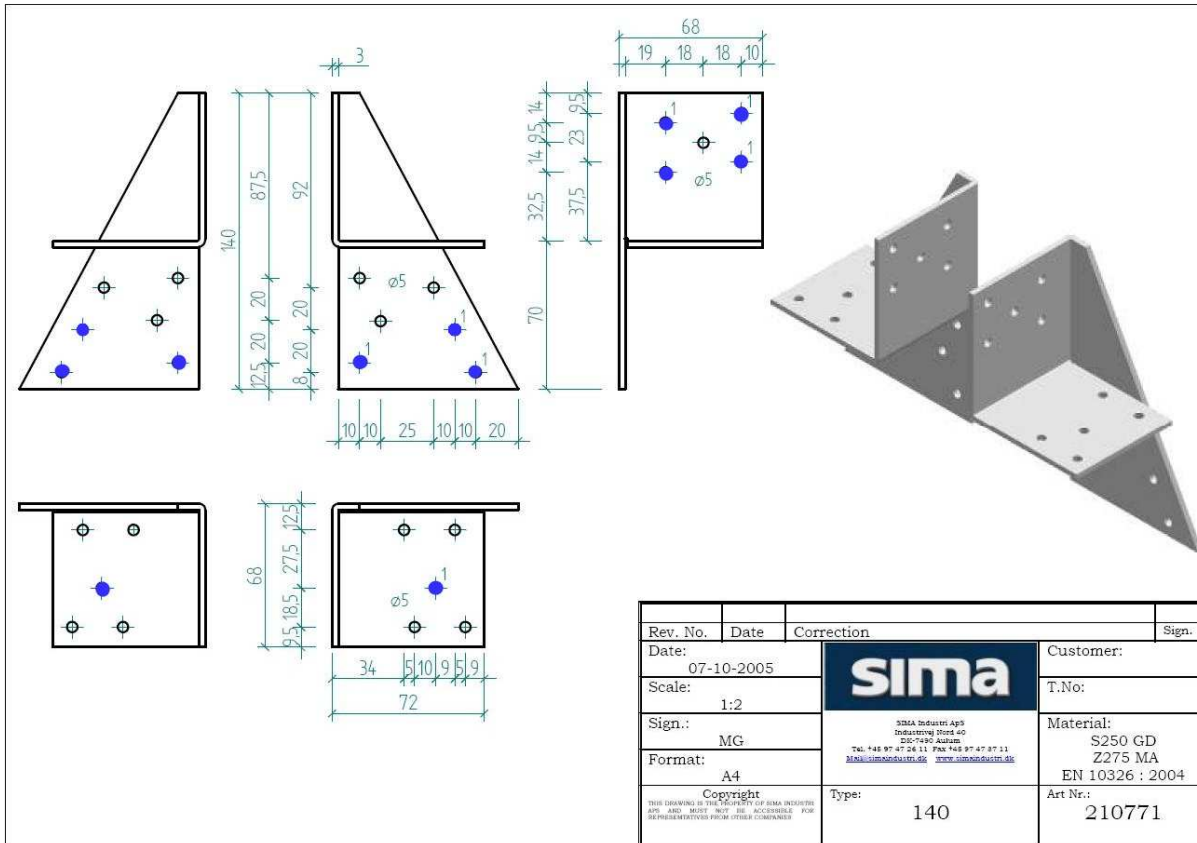

Universal connector 190

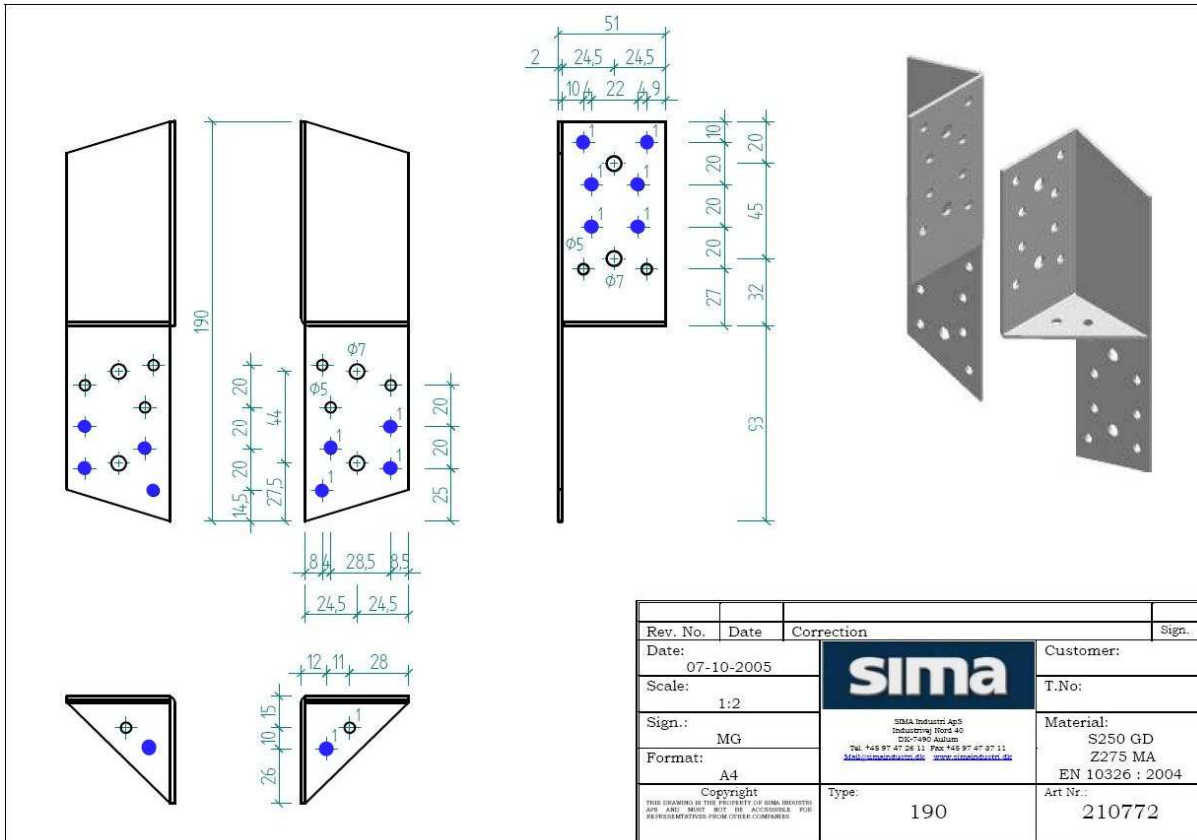

Universal Purlin anchor 170

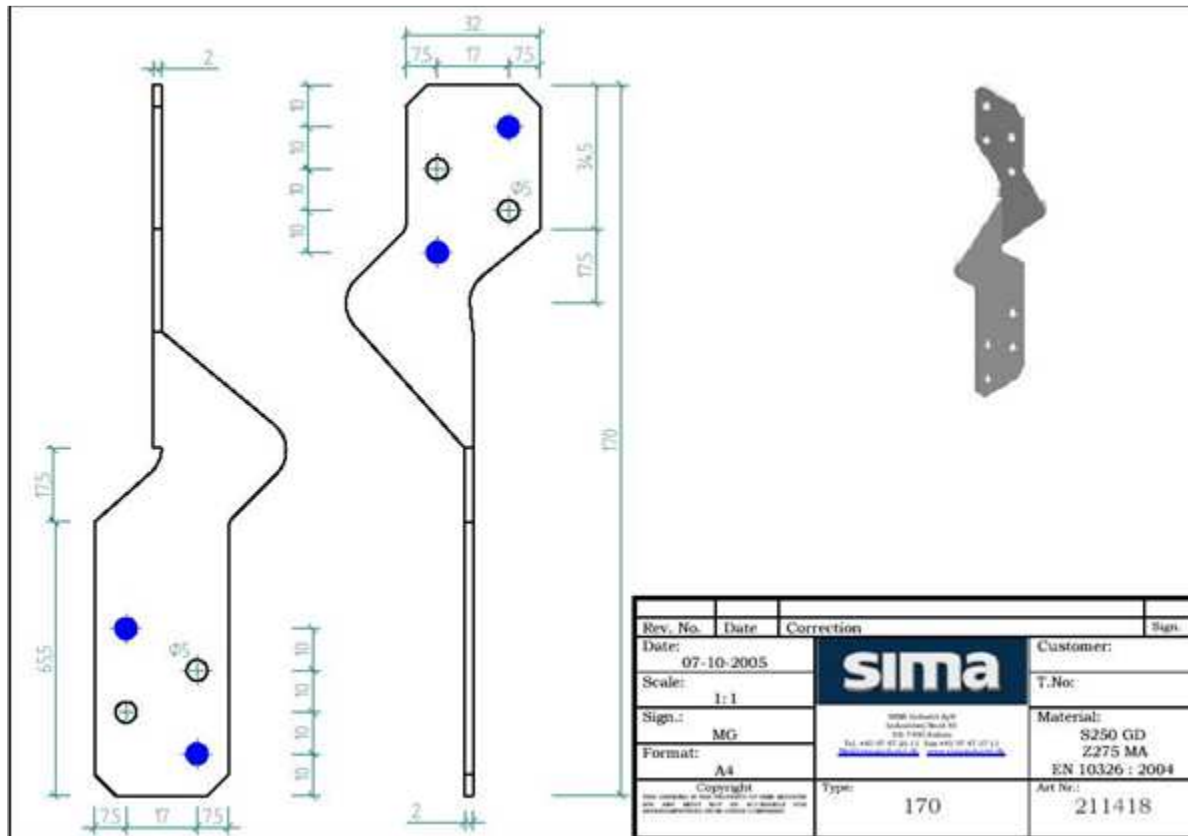

Universal Purlin anchor 210

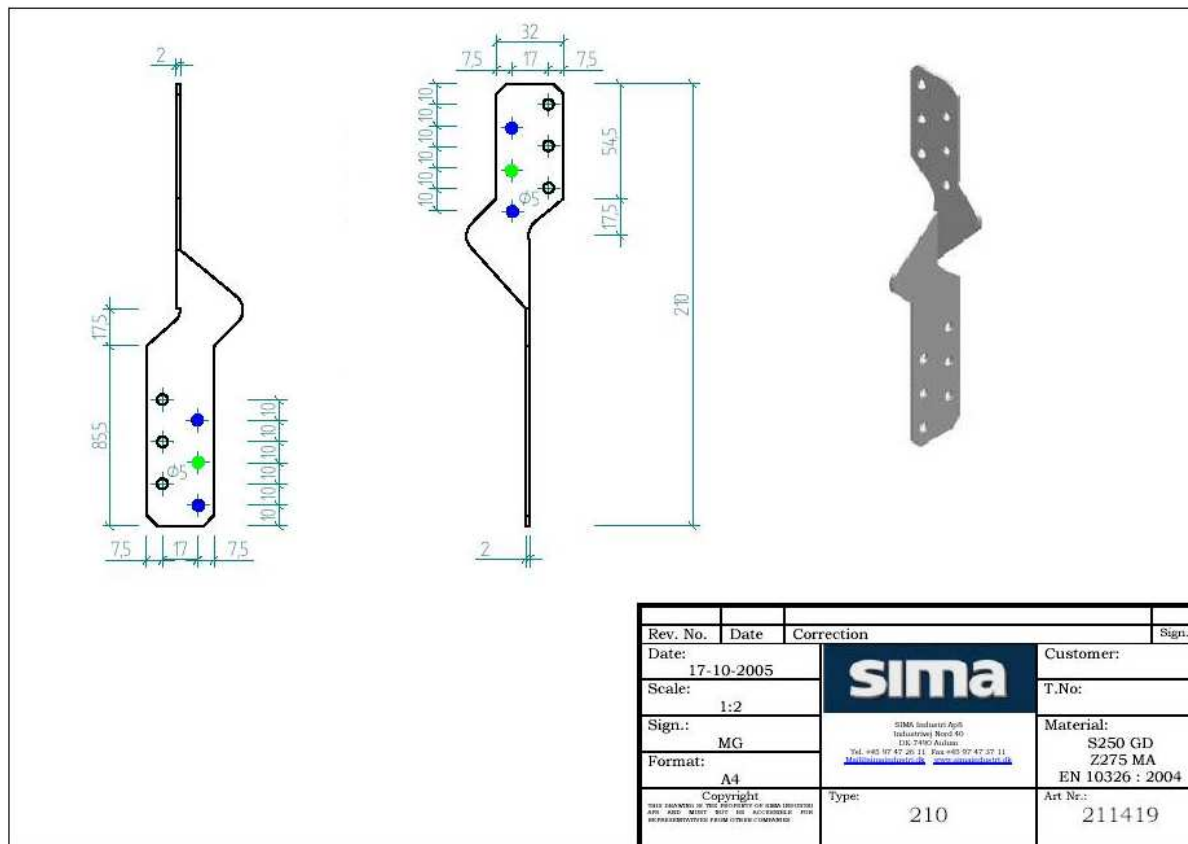

Characteristic capacities of the bracket connections with nails.

The upward directed force is assumed to act in the middle of the purlin.

More than one patterns are specified. A full nailing pattern, where there are nails in all the holes. Partial nailing patterns where the number of nails in the purlin and the beam are less than full nailing. The nails in the purlin may be staggered and there shall always be a nail in the upper and the lower holes. The other nails are distributed evenly over the height. The nails in the beam shall be put in the holes closest to the bend line.

The width of the purlin shall be at least the penetration length of the nails, for full nailing and partial nailing without staggering the nails in the purlin. For partial nailing with staggered nails in the purlin the width shall be at least the penetration length of the nails.

A.1 Brackets fastened with nails

$$R_{Up,k} = \min \{ n_{P,ef,1} \cdot R_{lat,P,k} ; n_B \cdot R_{lat,B,k} \}$$

where the following symbols are:

$n_{P,ef,1}$ effective number of nails in the side of the purlin

n_B total number of nails in the side of the beam

$R_{lat,k}$ characteristic lateral load-carrying capacity of the nails in the purlin or in the beam indicated by the indices P or B

$R_{ax,k}$ characteristic axial load-carrying capacity of the nails in the purlin or in the beam indicated by the indices P or B

Annex C Characteristic capacities

Fork/Rafter anchor

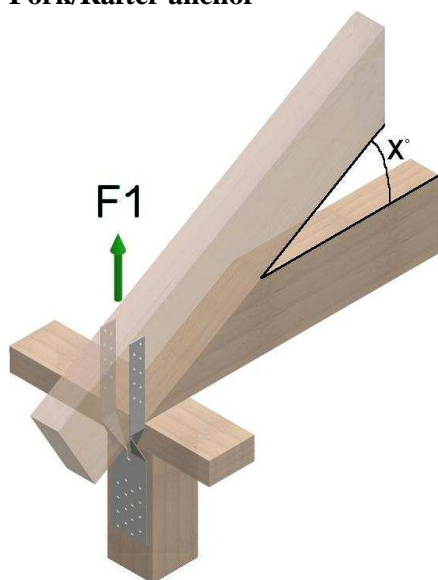

1 Fork Anchor pr connection

Paslode Connector nails 4,0 x 40	No. of nails pr connection	Load Duration	F1, [kN] 0° rafters	F1, [kN] 15° rafters	F1, [kN] 30° rafters	F1, [kN] 45° rafters
Nailing Holes marked blue	8	P	4,52	4,52	4,52	4,52
		L	5,28	5,28	5,28	5,28
		M	6,03	6,03	6,03	6,03
		S	6,78	6,78	6,78	6,78
		I	8,29	8,29	8,29	8,29
The characteristic values found by calculation			7,54	7,54	7,54	7,54
The values have been assessed in accordance with EC 5 Table 3.1- "Values of K_{mod} "						

Paslode Connector nails 4,0 x 40	No. of nails pr connection	Load Duration	F1, [kN] 0° rafters	F1, [kN] 15° rafters	F1, [kN] 30° rafters	F1, [kN] 45° rafters
Nailing Holes marked blue and green	12	P	6,78	6,29	5,74	4,91
		L	7,92	7,34	6,70	5,73
		M	9,05	8,39	7,65	6,55
		S	10,18	9,44	8,61	7,37
		I	12,44	11,54	10,53	9,01
The characteristic values found by calculation			11,31	10,49	9,57	8,19
The values have been assessed in accordance with EC 5 Table 3.1- "Values of K_{mod} "						

1 Rafter Anchor 2-36 pr. connection

Paslode Connector nails 4,0 x 40	No. of nails pr connection	Load Duration	F1, [kN] 0° rafters	F1, [kN] 15° rafters	F1, [kN] 30° rafters	F1, [kN] 45° rafters
Nailing Holes marked blue	22	P	11,31	4,78	4,26	3,54
		L	13,20	5,58	4,97	4,13
		M	13,37	6,38	5,68	4,72
		S	13,37	7,17	6,39	5,31
		I	13,37	8,77	7,81	6,49
The characteristic values found by calculation			13,37	7,97	7,10	5,90
The values have been assessed in accordance with EC 5 Table 3.1- "Values of K_{mod} "						

1 Rafter Anchor 2-48 pr. connection

Paslode Connector nails 4,0 x 40	No. of nails pr connection	Load Duration	F1, [kN] 0° rafters	F1, [kN] 15° rafters	F1, [kN] 30° rafters	F1, [kN] 45° rafters
Nailing Holes marked blue	22	P	11,31	6,37	5,68	4,72
		L	13,20	7,43	6,62	5,51
		M	13,37	8,50	7,57	6,30
		S	13,37	9,56	8,51	7,08
		I	13,37	11,68	10,41	8,66
The characteristic values found by calculation			13,37	10,62	9,46	7,87
The values have been assessed in accordance with EC 5 Table 3.1- "Values of K_{mod} "						

Purlin anchors

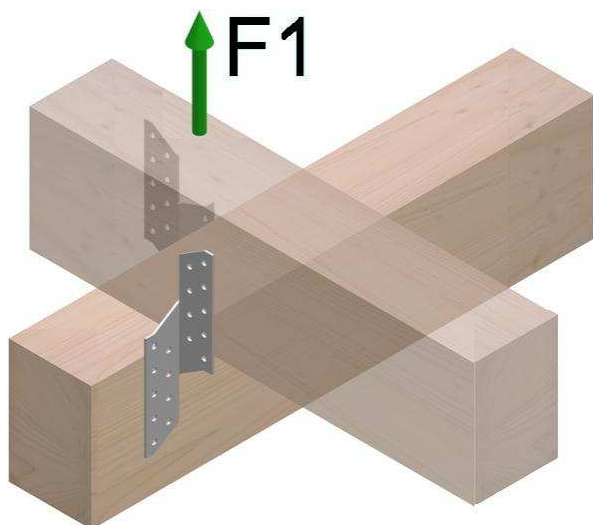

2 Purlin Anchors or Purlin Anchors PL pr. connection in any length

Fastener not taking into account	No. of fasteners pr connection	Load Duration	$F1_{steel}$, [kN]
Fastener	n	P	26,10
		L	26,10
		M	26,10
		S	26,10
		I	26,10
The characteristic values found by calculation			26,10
The values have been assessed in accordance with EC 5 Table 3.1- "Values of K_{mod} "			

2 Purlin Anchor 170 or 170PL pr. connection

Paslode Connector nails 4,0 x 40 pr connection		
Load Duration	F1, [kN] 8 nails Holes: 1	F1, [kN] 12 nails Holes: 1,2
P	4,52	4,52
L	5,28	5,28
M	6,03	6,03
S	6,79	6,79
I	8,29	8,29
Characteristic values found by calculation	7,54	7,54
The values have been assessed in accordance with EC 5 Table 3.1- "Values of K_{mod} "		

2 Purlin Anchors 170-1 or 170-1PL pr. connection

Paslode Connector nails 4,0 x 40 pr connection		
Load Duration	F1, [kN] 8 nails Holes: 1	F1, [kN] 12 nails Holes: 1,2
P	4,52	4,52
L	5,28	5,28
M	6,03	6,03
S	6,79	6,79
I	8,29	8,29
Characteristic values found by calculation	7,54	7,54
The values have been assessed in accordance with EC 5 Table 3.1- "Values of K_{mod} "		

2 Purlin Anchors 210 or 210PL pr. connection

Paslode Connector nails 4,0 x 40 pr connection				
Load Duration	F1, [kN] 8 nails Holes: 1	F1, [kN] 12 nails Holes: 1,2	F1, [kN] 16 nails Holes: 1-3	F1, [kN] 20 nails Holes: 1-4
P	4,52	6,79	6,79	6,79
L	5,28	7,92	7,92	7,92
M	6,03	9,05	9,05	9,05
S	6,79	10,18	10,18	10,18
I	8,29	12,44	12,44	12,44
Characteristic values found by calculation	7,54	11,31	11,31	11,31
The values have been assessed in accordance with EC 5 Table 3.1- "Values of K_{mod} "				

2 Purlin Anchors 210-1 or 210-1PL pr. connection

Paslode Connector nails 4,0 x 40 pr connection		
Load Duration	F1, [kN] 8 nails Holes: 1	F1, [kN] 12 nails Holes: 1,2
P	4,52	6,79
L	5,28	7,92
M	6,03	9,05
S	6,79	10,18
I	8,29	12,44
Characteristic values found by calculation	7,54	11,31
The values have been assessed in accordance with EC 5 Table 3.1- "Values of K_{mod} "		

2 Purlin Anchors 250 or 250PL pr. connection

Paslode Connector nails 4,0 x 40 pr connection					
Load Duration	F1, [kN] 8 nails Holes: 1	F1, [kN] 12 nails Holes: 1,2	F1, [kN] 16 nails Holes: 1-3	F1, [kN] 20 nails Holes: 1-4	F1, [kN] 24 nails Holes: 1-5
P	4,52	6,79	9,05	9,05	9,05
L	5,28	7,92	10,56	10,56	10,56
M	6,03	9,05	12,06	12,06	12,06
S	6,79	10,18	13,57	13,57	13,57
I	8,29	12,44	16,59	16,59	16,59
Characteristic values found by calculation	7,54	11,31	15,08	15,08	15,08
The values have been assessed in accordance with EC 5 Table 3.1- "Values of K_{mod} "					

2 Purlin Anchors 290 or 290PL pr. connection

Paslode Connector nails 4,0 x 40 pr connection					
Load Duration	F1, [kN] 8 nails Holes: 1	F1, [kN] 12 nails Holes: 1,2	F1, [kN] 16 nails Holes: 1-3	F1, [kN] 20 nails Holes: 1-4	F1, [kN] 24 nails Holes: 1-5
P	4,52	6,79	9,05	11,31	11,31
L	5,28	7,92	10,56	13,20	13,20
M	6,03	9,05	12,06	15,08	15,08
S	6,79	10,18	13,57	16,97	16,97
I	8,29	12,44	16,59	20,74	20,74
Characteristic values found by calculation	7,54	11,31	15,08	18,85	18,85
The values have been assessed in accordance with EC 5 Table 3.1- "Values of K_{mod} "					

2 Purlin Anchors 330 or 330PL pr. connection

Paslode Connector nails 4,0 x 40 pr connection					
Load Duration	F1, [kN] 8 nails Holes: 1	F1, [kN] 12 nails Holes: 1,2	F1, [kN] 16 nails Holes: 1-3	F1, [kN] 20 nails Holes: 1-4	F1, [kN] 24 nails Holes: 1-5
P	4,52	6,79	9,05	11,31	13,57
L	5,28	7,92	10,56	13,20	15,83
M	6,03	9,05	12,06	15,08	18,10
S	6,79	10,18	13,57	16,97	20,36
I	8,29	12,44	16,59	20,74	24,88
Characteristic values found by calculation	7,54	11,31	15,08	18,85	22,62
The values have been assessed in accordance with EC 5 Table 3.1- "Values of K_{mod} "					

2 Purlin Anchors 370 or 370PL pr. connection

Paslode Connector nails 4,0 x 40 pr connection					
Load Duration	F1, [kN] 8 nails Holes: 1	F1, [kN] 12 nails Holes: 1,2	F1, [kN] 16 nails Holes: 1-3	F1, [kN] 20 nails Holes: 1-4	F1, [kN] 24 nails Holes: 1-5
P	4,52	6,79	9,05	11,31	13,57
L	5,28	7,92	10,56	13,20	15,83
M	6,03	9,05	12,06	15,08	18,10
S	6,79	10,18	13,57	16,97	20,36
I	8,29	12,44	16,59	20,74	24,88
Characteristic values found by calculation	7,54	11,31	15,08	18,85	22,62
The values have been assessed in accordance with EC 5 Table 3.1- "Values of K_{mod} "					

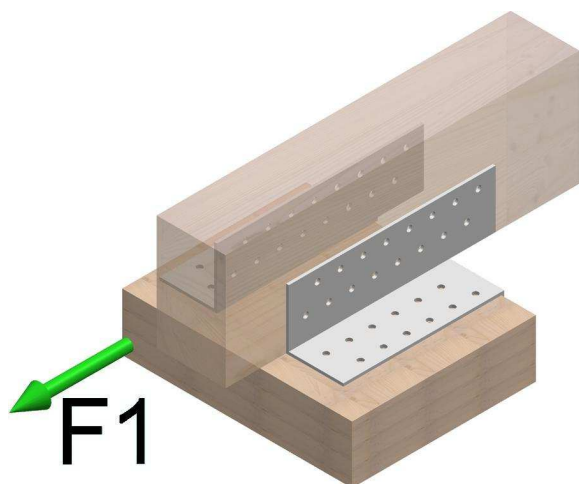
Rafter connector**2 Rafter Connectors 180 pr. connection**

Paslode Connector nails 4,0 x 40 pr connection		
Load Duration	F1, [kN] 32 nails Blue holes	F1, [kN] 62 nails Blue + Green holes
P	17,14	17,14
L	20,00	20,00
M	22,86	22,86
S	25,71	25,71
I	31,43	31,43
Characteristic values found by calculation	28,57	28,57
The values have been assessed in accordance with EC 5 Table 3.1- "Values of K_{mod} "		

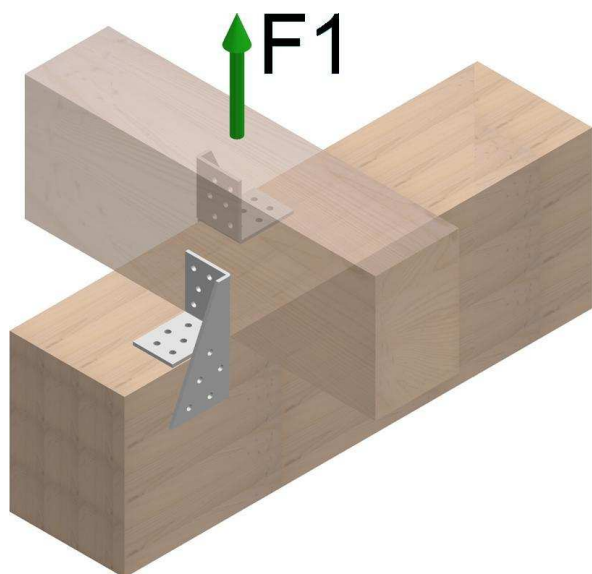
Universal connector**2 Universal Connectors 100 pr. connection**

Paslode Connector nails 4,0 x 40	No. of nails pr connection	Load Duration	F1, [kN]
Nailing Holes marked blue	10	P	4,52
		L	5,28
		M	6,03
		S	6,79
		I	8,29
The characteristic values found by calculation			7,54
The values have been assessed in accordance with EC 5 Table 3.1- "Values of K_{mod} "			

2 Universal Connectors 140 pr. connection

Paslode Connector nails 4,0 x 40	No. of nails pr connection	Load Duration	F1, [kN]
Nailing Holes marked blue	16	P	7,99
		L	9,32
		M	10,65
		S	11,98
		I	14,64
The characteristic values found by calculation			13,31
The values have been assessed in accordance with EC 5 Table 3.1- "Values of K_{mod} "			

2 Universal Connectors 190 pr. connection

Paslode Connector nails 4,0 x 40	No. of nails pr connection	Load Duration	F1, [kN]
Nailing Holes marked blue	22	P	10,25
		L	11,96
		M	13,66
		S	15,37
		I	18,79
The characteristic values found by calculation			17,08
The values have been assessed in accordance with EC 5 Table 3.1- "Values of K_{mod} "			

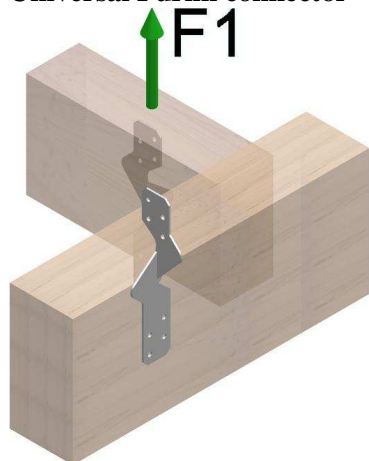
Universal Purlin connector**2 Universal Purlin Anchors 170 pr. connection**

Paslode Connector nails 4,0 x 40	No. of nails pr connection	Load Duration	F1, [kN] 8 nails Blue holes
Nailing Holes marked blue	8	P	4,52
		L	5,28
		M	6,03
		S	6,79
		I	8,29
The characteristic values found by calculation			7,54
The values have been assessed in accordance with EC 5 Table 3.1- "Values of K_{mod} "			

2 Universal Purlin Anchors 210 pr. connection

Paslode Connector nails 4,0 x 40 pr connection		
Load Duration	F1, [kN] 8 nails Blue holes	F1, [kN] 12 nails Blue + Green holes
P	4,52	6,79
L	5,28	7,92
M	6,03	9,05
S	6,79	10,18
I	8,29	12,44
Characteristic values found by calculation	7,54	11,31
The values have been assessed in accordance with EC 5 Table 3.1- "Values of K_{mod} "		