

Centre Scientifique et Technique du Bâtiment

84 avenue Jean Jaurès
Champs sur Marne
F-77447 Marne-la-Vallée Cedex 2
Tél. : (33) 01 64 68 82 82
Fax : (33) 01 60 05 70 37

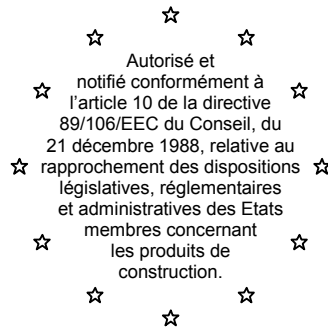

CSTB
le futur en construction

MEMBRE DE L'EOTA

European Technical Approval

ETA-05/0111

(English language translation, the original version is in French language)

Nom commercial :

Trade name:

SPIT EPOMAX

Titulaire :

Holder of approval:

Société SPIT

Route de Lyon

F-26501 BOURG-LES-VALENCE

France

Type générique et utilisation prévue du produit de construction :

Cheville à scellement de type "à injection" avec tige d'ancrage diamètres M8, M10, M12, M16, M20, M24 et M30 ou douille taraudée diamètres M8, M10, M12, M16, M20, pour fixation dans le béton non fissuré.

Generic type and use of construction product:

Bonded injection type anchor with anchor rod sizes M8, M10, M12, M16, M20, M24 and M30 or internal sleeve sizes M8, M10, M12, M16 and M20 for use in non cracked concrete.

Validité du :

au :

Validity from / to:

05/06/2012

05/06/2017

Usine de fabrication :

Manufacturing plant:

Société SPIT

Route de Lyon

F-26501 BOURG-LES-VALENCE

France

Le présent Agrément technique européen contient :

This European Technical Approval contains:

22 pages incluant 12 annexes faisant partie intégrante du document.

22 pages including 12 annexes which form an integral part of the document.

This European Technical Approval replaces ETA-05/0111 with validity from 05/06/2007 au 05/06/2012

Cet Agrément Technique Européen remplace l'Agrément ETA-05/0111 valide du 05/06/2007 au 05/06/2012



Organisation pour l'Agrément Technique Européen
European Organisation for Technical Approvals

I LEGAL BASES AND GENERAL CONDITIONS

1. This European Technical Approval is issued by the Centre Scientifique et Technique du Bâtiment in accordance with:

- Council Directive 89/106/EEC of 21 December 1988 on the approximation of laws, regulations and administrative provisions of Member States relating to construction products¹, modified by the Council Directive 93/68/EEC of 22 July 1993²;
- Décret n° 92-647 du 8 juillet 1992³ concernant l'aptitude à l'usage des produits de construction;
- Common Procedural Rules for Requesting, Preparing and the Granting of European Technical Approvals set out in the Annex of Commission Decision 94/23/EC⁴;
- Guideline for European Technical Approval of « Metal Anchors for use in Concrete » ETAG 001, edition 1997, Part 1 « Anchors in general » and Part 5 « Bonded anchors».

2. The Centre Scientifique et Technique du Bâtiment is authorised to check whether the provisions of this European Technical Approval are met. Checking may take place in the manufacturing plant (for example concerning the fulfilment of assumptions made in this European Technical Approval with regard to manufacturing). Nevertheless, the responsibility for the conformity of the products with the European Technical Approval and for their fitness for the intended use remains with the holder of the European Technical Approval.

3. This European Technical Approval is not to be transferred to manufacturers or agents of manufacturer other than those indicated on page 1; or manufacturing plants other than those indicated on page 1 of this European Technical Approval.

4. This European Technical Approval may be withdrawn by the Centre Scientifique et Technique du Bâtiment pursuant to Article 5 (1) of the Council Directive 89/106/EEC.

5. Reproduction of this European Technical Approval including transmission by electronic means shall be in full. However, partial reproduction can be made with the written consent of the Centre Scientifique et Technique du Bâtiment. In this case partial reproduction has to be designated as such. Texts and drawings of advertising brochures shall not contradict or misuse the European Technical Approval.

6. The European Technical Approval is issued by the approval body in its official language. This version corresponds to the version circulated within EOTA. Translations into other languages have to be designated as such.

¹ Official Journal of the European Communities n° L 40, 11.2.1989, p. 12
² Official Journal of the European Communities n° L 220, 30.8.1993, p. 1
³ Journal officiel de la République française du 14 juillet 1992
⁴ Official Journal of the European Communities n° L 17, 20.1.1994, p. 34

II SPECIFIC CONDITIONS OF THE EUROPEAN TECHNICAL APPROVAL

1 Definition of product and intended use

1.1. Definition of product

The SPIT EPOMAX is a bonded anchor (injection type) with anchor rod or internal sleeve made of galvanised steel or stainless steel or stainless steel high corrosion resistance (HCR), which is placed into a drilled hole previously injected with a two components injection mortar using an applicator gun equipped with a special mixing nozzle. The anchor rod, or internally threaded sleeve is inserted into the resin with a slow and slight twisting motion. The mortar cartridges are available in different sizes (150 ml to 825 ml) and systems (coaxial or side by side). The anchor rod is intended to be used with embedment depth from 8 diameters to 12 diameters

The galvanised steel anchor rods are available with:

- ✓ a helical end (M8 to M16),
- ✓ with a two sides 45° chamfer (M20 to M30)
- ✓ with a flat end

The Galvanised internal sleeve anchor is available in the diameter M8 to M20.

The stainless steel threaded rods are available for all diameters:

- ✓ with a two sides 45° chamfer
- ✓ with a flat end

The stainless steel internal sleeve is available in the diameter M8 to M16.

The threaded rods are either delivered with the mortar cartridges or commercial standard threaded rods purchased separately (A4/70 for M8 to M24 and A4/50 for M30).

For the installed anchor see Figure given in Annex 2.

1.2. Intended use

The anchor is intended to be used for anchorages for which requirements for mechanical resistance and stability and safety in use in the sense of the Essential Requirements 1 and 4 of Council Directive 89/106/EEC shall be fulfilled and failure of anchorages made with these products would compromise the stability of the works, cause risk to human life and/or lead to considerable economic consequences. Safety in case of fire (Essential Requirement 2) is not covered in this ETA. The anchor is to be used only for anchorages subject to static or quasi-static loading in reinforced or unreinforced normal weight concrete of strength classes C 20/25 at least to C50/60 at most according to ENV 206: 2000-12. It may be anchored in non-cracked concrete only.

Galvanised steel anchor elements: The anchor may only be used in concrete subject to dry internal conditions.

Stainless steel elements: The anchor may be used in concrete subject to dry internal conditions and also in concrete subject to external atmospheric exposure (including industrial and marine

environment), or exposure in permanently damp internal conditions, if no particular aggressive conditions exist. Such particular aggressive conditions are e.g. permanent, alternating immersion in seawater or the splash zone of seawater, chloride atmosphere of indoor swimming pools or atmosphere with extreme chemical pollution (e.g. in desulphurization plants or road tunnels where de-icing materials are used).

High corrosion resistant (HCR) stainless steel elements: (commercial standard threaded rods) may be used in structures subject to dry internal conditions and also in structures subject to external atmospheric exposure, in permanently damp internal conditions or in other particular aggressive conditions. Such particular conditions are e.g. permanent, alternating immersion in seawater or the splash zone of seawater, chloride atmosphere of indoor swimming pools or atmosphere with chemical pollution (e.g. in desulphurization plants or road tunnels where de-icing materials are used).

The anchor may be installed in dry or wet concrete or in flooded holes excepting sea water (use category 2) for all diameters.

Installation	Substrate		
	Dry concrete	Wet concrete	Flooded hole
All diameters	Yes	Yes	Yes

All the diameters (i.e. from M8 to M30) may be used overhead.

The anchor may be used in the following temperature ranges :

Temperature range I :-40°C to +40°C (max short term temperature +40°C and max long term temperature +24°C)

Temperature range II :-40°C to +80°C (max short term temperature +80°C and max long term temperature +50°C)

Temperature range III :-40°C to +120°C (max short term temperature +120°C and max long term temperature +72°C)

The provisions made in this European Technical Approval are based on an assumed intended working life of the anchor of 50 years. The indications given on the working life cannot be interpreted as a guarantee given by the producer, but are to be regarded only as a means for choosing the right products in relation to the expected economically reasonable working life of the works.

2 Characteristics of product and methods of verification

2.1. Characteristics of product

The anchor rods in the sizes of M8 to M30, the internal sleeves and the mortar cartridges correspond to the drawings and provisions given in Annexes 1 to 4. The characteristic material values, dimensions and tolerances of the anchor not indicated in the Annexes shall correspond to the respective values laid down in the technical documentation⁵ of this European Technical

⁵ The technical documentation of this European Technical Approval is deposited at the Centre Scientifique et Technique du Bâtiment and, as far as relevant for the tasks of the approved bodies involved in the attestation of conformity procedure, is handed over to the approved bodies.

Approval. The characteristic anchor values for the design of anchorages are given in Annexes 9 to 12.

Each mortar cartridge is marked with the identifying mark of the producer, the trade name, the charge code, storage life, curing and processing time. Each internal sleeve is marked on the cap with the letter S (company label) and the nominal diameter. Each anchor rod with helical end is marked with the letter S (company label), the nominal diameter of the threaded part of the rod and thickness of the fixture according to the description given in annex 2. Alternatively, commercial standard threaded rods can be used. If the threaded rods are supplied separately by another party than the approval holder, then it shall be ensured:

- Mechanical properties according to EN ISO 898-1
- Quality affirmation of the mechanical properties with an inspection document according to EN 10204
- Marking the envisage embedment depth.

The two components of the SPIT injection mortar EPOMAX could be delivered in unmixed condition in mortar cartridges in a size of 150 ml, 300 ml and 380 ml in case of coaxial cartridges, 345 ml and 825 ml in case of side by side cartridges according to Annex 3.

2.2. Methods of verification

The assessment of fitness of the anchor for the intended use in relation to the requirements for mechanical resistance and stability and safety in use in the sense of the Essential Requirements 1 and 4 has been made in accordance with the « Guideline for European Technical Approval of Metal Anchors for use in Concrete », Part 1 « Anchors in general » and Part 5 « Bonded anchors », on the basis of Option 7.

In addition to the specific clauses relating to dangerous substances contained in this European Technical Approval, there may be other requirements applicable to the products falling within its scope (e.g. transposed European legislation and national laws, regulations and administrative provisions). In order to meet the provisions of the UE Construction Products Directive, these requirements need also to be complied with, when and where they apply.

3 Evaluation of Conformity and CE marking

3.1. Attestation of conformity system

The system of attestation of conformity 2 (i) (referred to as system 1) according to Council Directive 89/106/EEC Annex III laid down by the European Commission provides:

a) tasks for the manufacturer:

1. factory production control,
2. further testing of samples taken at the factory by the manufacturer in accordance with a prescribed test plan.

b) tasks for the approved body:

3. initial type-testing of the product,
4. initial inspection of factory and of factory production control,

5. continuous surveillance, assessment and approval of factory production control.

3.2. Responsibilities

3.2.1. Tasks of the manufacturer, factory production control

The manufacturer has a factory production control system in the plant and exercises permanent internal control of production. All the elements, requirements and provisions adopted by the manufacturer are documented in a systematic manner in the form of written policies and procedures. This production control system ensures that the product is in conformity with the European Technical Approval.

The manufacturer shall only use raw materials supplied with the relevant inspection documents as laid down in the prescribed test plan⁶. The incoming raw materials shall be subject to controls and tests by the manufacturer before acceptance. Check of incoming materials such as nuts, washers, threaded rods, resin, hardeners... shall include control of the inspection documents presented by suppliers (comparison with nominal values) by verifying dimension and determining material properties, e.g. tensile strength, surface finish.

The frequency of controls and tests conducted during production is laid down in the prescribed test plan taking account of the automated manufacturing process of the anchor.

The results of factory production control are recorded and evaluated. The records include at least the following information:

- designation of the product, basic material and components;
- type of control or testing;
- date of manufacture of the product and date of testing of the product or basic material and components;
- result of control and testing and, if appropriate, comparison with requirements;
- signature of person responsible for factory production control.

The records shall be presented to the inspection body during the continuous surveillance. On request, they shall be presented to the Centre Scientifique et Technique du Bâtiment.

Details of the extent, nature and frequency of testing and controls to be performed within the factory production control shall correspond to the prescribed test plan which is part of the technical documentation of this European Technical Approval.

3.2.2. Tasks of approved bodies

3.2.2.1. Initial type-testing of the product

For initial type-testing the results of the tests performed as part of the assessment for the European Technical Approval shall be used unless there are changes in the production line or plant. In such cases the necessary initial type-testing has to be agreed between the Centre Scientifique et Technique du Bâtiment and the approved bodies involved.

3.2.2.2. Initial inspection of factory and of factory production control

⁶

The prescribed test plan has been deposited at the Centre Scientifique et Technique du Bâtiment and is only made available to the approved bodies involved in the conformity attestation procedure.

The approved body shall ascertain that, in accordance with the prescribed test plan, the factory and the factory production control are suitable to ensure continuous and orderly manufacturing of the anchor according to the specifications mentioned in 2.1. as well as to the Annexes to the European Technical Approval.

3.2.2.3. Continuous surveillance

The approved body shall visit the factory at least once a year for regular inspection. It has to be verified that the system of factory production control and the specified automated manufacturing process are maintained taking account of the prescribed test plan.

Continuous surveillance and assessment of factory production control have to be performed according to the prescribed test plan.

The results of product certification and continuous surveillance shall be made available on demand by the certification body or inspection body, respectively, to the Centre Scientifique et Technique du Bâtiment. In cases where the provisions of the European Technical Approval and the prescribed test plan are no longer fulfilled the conformity certificate shall be withdrawn.

3.3. CE-Marking

The CE marking shall be affixed on each packaging of anchors. The symbol « CE » shall be accompanied by the following information:

- identification number of the certification body;
- name or identifying mark of the producer and manufacturing plant;
- the last two digits of the year in which the CE-marking was affixed;
- number of the EC certificate of conformity;
- number of the European Technical Approval;
- use category (ETAG 001-5 Option 7);
- size.

4 Assumptions under which the fitness of the product for the intended use was favourably assessed

4.1. Manufacturing

The anchor is manufactured in accordance with the provisions of the European Technical Approval using the automated manufacturing process as identified during inspection of the plant by the Centre Scientifique et Technique du Bâtiment and the approved body and laid down in the technical documentation.

4.2. Installation

4.2.1. Design of anchorages

The suitability of the anchor for the intended use is given under the following conditions:

The anchorages are designed in accordance with the EOTA Technical Report TR 029⁷ "Design of bonded anchors" under the responsibility of an engineer experienced in anchorages and concrete work. Verifiable calculation notes and drawings are prepared taking account of the loads

⁷ The Technical Report TR 029 "Design of Bonded Anchors" is published in English on EOTA website: www.eota.eu.

to be anchored. The position of the anchor is indicated on the design drawings (e.g. position of the anchor relative to reinforcement or to supports, etc.).

4.2.2. Installation of anchors

The fitness for use of the anchor can only be assumed if the anchor is installed as follows:

- anchor installation carried out by appropriately qualified personnel and under the supervision of the person responsible for technical matters on the site;
- use of the anchor only as supplied by the manufacturer without exchanging the components of an anchor;
- anchor installation in accordance with the manufacturer's specifications and drawings using the tools indicated in the technical documentation of this European Technical Approval;
- checks before placing the anchor to ensure that the strength class of the concrete in which the anchor is to be placed is in the range;
- check of concrete being well compacted, e.g. without significant voids;
- keeping the effective anchorage depth;
- keeping of the edge distance and spacing to the specified values without minus tolerances;
- positioning of the drill holes without damaging the reinforcement;
- in case of aborted drill hole: the drill hole shall be filled with mortar;
- Cleaning of the hole: Standard cleaning
 - cleaning the hole of drilling dust : the hole shall be cleaned by at least four blowing operations with hand pump, by at least four manual brushing operations followed again by at least four blowing operations; before brushing cleaning the brush and checking whether the brush diameter according to Annex 5 Table 2 is sufficient;
- Cleaning of the hole: Premium cleaning
 - cleaning the hole of drilling dust : the hole shall be cleaned by at least two blowing operations with compressed air & an air pistol, by at least two mechanical brushing operations followed again by at two blowing operations; before brushing cleaning the brush and checking whether the brush diameter according to Annex 5 Table 2 is sufficient;
- anchor installation ensuring the specified embedment depth, that is the appropriate depth marking of the anchor not exceeding the concrete surface;
- mortar injection by using the equipment including the special mixing nozzle shown in Annex 3; discarding the first swings of mortar of each new cartridge until an homogeneous colour is achieved; taking from the manufacturer instruction the admissible processing time (open time) of a cartridge as a function of the ambient temperature of the concrete; filling the drill hole uniformly from the drill hole bottom, in order to avoid entrapment of air; removing the special mixing nozzle slowly bit by bit during pressing-out; filling the drill hole with a quantity of the injection mortar corresponding to $\frac{1}{2}$ of the drill hole; inserting immediately the anchor rod or threaded rod, slowly and with a slight twisting motion, removing excess of injection mortar around the rod; observing the curing time according to Annex 5 table 2 until the rod may be loaded; during curing of the injection mortar the temperature of the concrete must not fall below 0°C;
- application of the torque moment given in Annex 8 Tables 4 and 5 using a calibrated torque wrench.

4.2.3. Responsibility of the manufacturer

It is the manufacturer's responsibility to ensure that the information on the specific conditions according to 1 and 2 including Annexes referred to in 4.2.1. and 4.2.2. is given to those who are concerned. This information may be made by reproduction of the respective parts of the European Technical Approval. In addition all installation data shall be shown clearly on the package and/or on an enclosed instruction sheet, preferably using illustration(s).

The minimum data required are:

- drill bit diameter,
- thread diameter,
- maximum thickness of the fixture,
- minimum installation depth,
- required torque moment,
- admissible service temperature range,
- curing time of the bonding material depending on the installation temperature,
- information on the installation procedure, including cleaning of the hole, preferably by means of an illustration,
- reference to any special installation equipment needed,
- identification of the manufacturing batch.

All data shall be presented in a clear and explicit form.

5 Recommendations concerning packaging, transport and storage.

The mortar cartridges shall be protected against sun radiation and shall be stored according to the manufacturer's installation instructions in dry conditions at temperatures of at least 0°C to not more than +35°C.

Mortar cartridges with expired shelf life must no longer be used.

**The original French version is
signed by**

**Le Directeur Technique
C. BALOCHE**

Threaded rod: Schema of the anchor in use

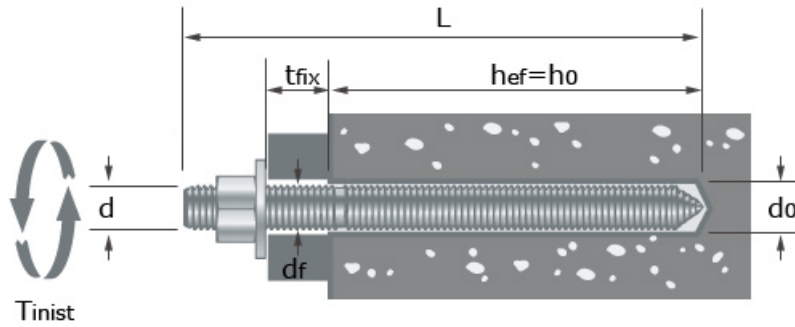

ATP internal sleeves: Schema of the anchor in use

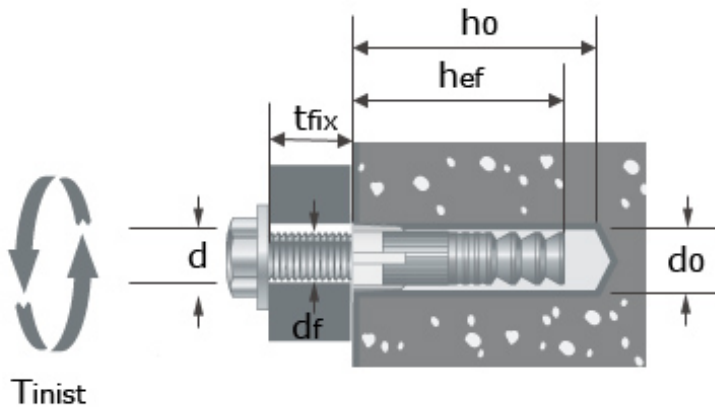

Intended use

Use category 2 (according to ETAG 001-5):

- ✓ Installation in dry or wet concrete
- ✓ Installation in flooded holes

Overhead installation is permitted

Temperature ranges:

- ✓ -40°C to +40°C (max. short term temperature +40°C and max. long term temperature +24°C)
- ✓ -40°C to +80°C (max. short term temperature +80°C and max. long term temperature +50°C)
- ✓ -40°C to +120°C (max. short term temperature +120°C and max. long term temperature +72°C)

SPIT EPOMAX

Product and intended use

**Annex 1
 of European Technical
 Approval
 ETA-05/0111**

Assembled anchor:

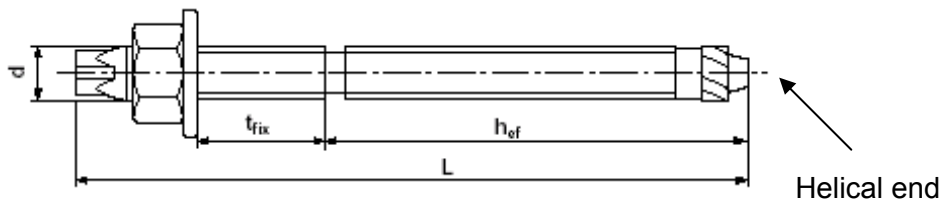

Anchor rods "S" M8 to M16 (Electroplated version)

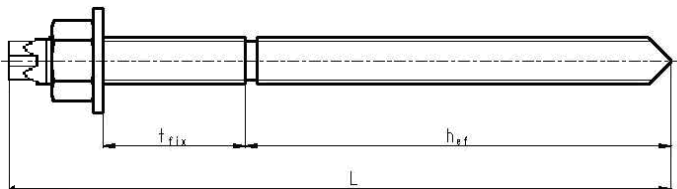

Anchor rods SPIT MAXIMA M8 to M16 (Stainless steel version)

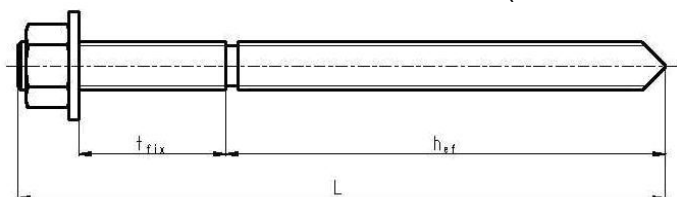

Anchor rods SPIT MAXIMA M20 to M30 (Electroplated / Stainless steel versions)

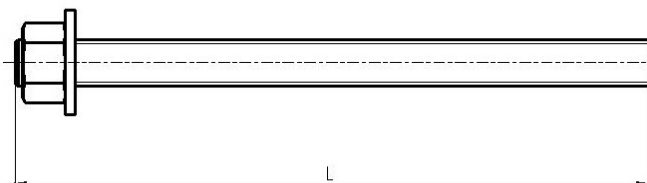

Commercial standard threaded rods with identifying mark of the embedment depth

Marking on the anchor rod: letter S, bolt diameter and maximum thickness of the fixture :
 Ex: S M10 / 20

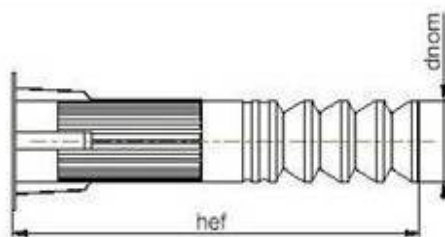

ATP internal sleeve

Marking on the internal threaded sleeve: letter S, bolt diameter + White plastic cap:
 Ex: S M12

SPIT EPOMAX

Product and intended use

**Annex 2
 of European Technical
 Approval
 ETA-05/0111**

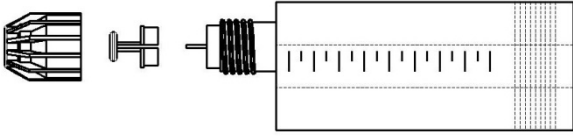
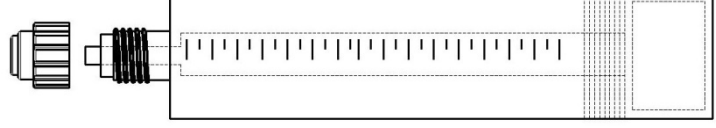
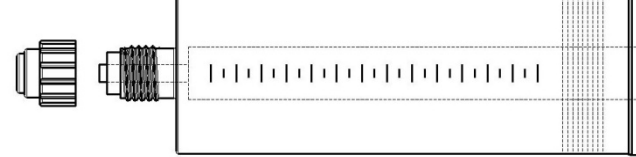
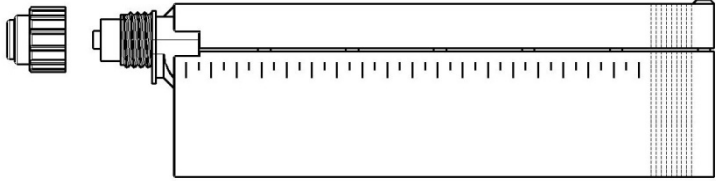
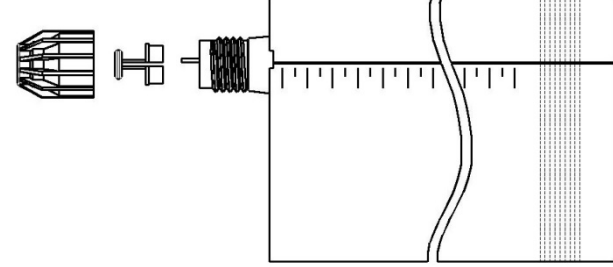
150ml coaxial cartridge	
300ml coaxial cartridge	
380ml coaxial cartridge	
345 ml side by side cartridge	
825 ml side by side cartridge	

Marking of the mortar cartridges :

- Identifying mark of the producer
- Trade name
- Charge code number
- Storage life
- Curing and processing time

Special mixing nozzles

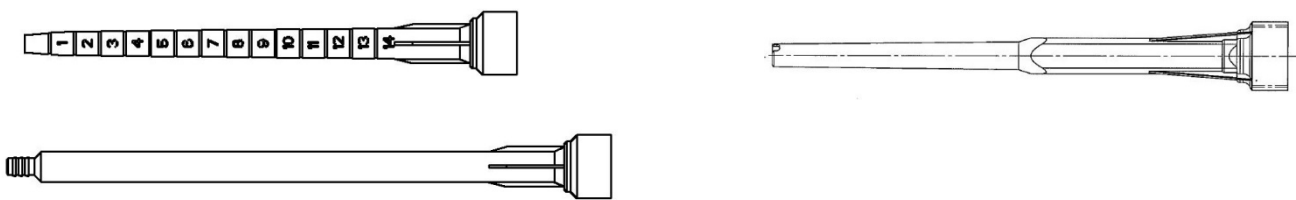

SPIT EPOMAX

Mortar cartridges

**Annex 3
 of European Technical Approval
 ETA-05/0111**

Table 1: Materials

Designation	Material
Injection mortar	Styrenefree vinylester resin, hardener and inorganic agents
Elements made of zinc coated steel	
“S” Threaded rod M8 – M16 (produced by the manufacturer)	M8 : Cold formed steel acc. DIN 1654 part 2 or 4 or NFA 35053 M10 to M16 : cold formed steel acc. NFA 35053 Zinc coating $\geq 5\mu\text{m}$ NF E25-009,
Threaded rod MAXIMA M20 – M30 (produced by the manufacturer)	11SMnPb37 :NF A35-561, Zinc coating $\geq 5\mu\text{m}$ NF E25-009,
Threaded rod M8 – M30 (standard commercial rods)	Strength class 5.8, 8.8, 10.9 EN ISO 898-1, Zinc coating $\geq 5\mu\text{m}$ NF E25-009,
Washer	Steel DIN 513 Zinc coating $\geq 5\mu\text{m}$ NF E25-009,
Nut	Steel, EN 20898-2 Grade 6 or 8 Zinc coating $\geq 5\mu\text{m}$ NF E25-009,
Elements made of stainless steel A4	
Threaded rod M8 – M30	Stainless steel A4-70: 1.4401; 1.4404; 1.4578; 1.4571; 1.4439; 1.4362 acc. EN 10088
Washer	Stainless steel A4-70: 1.4401; 1.4404; 1.4578; 1.4571; 1.4439; 1.4362 EN 10088
Nut	Strength class 80 EN ISO 3506-2 Stainless steel 1.4401; 1.4404; 1.4578; 1.4571; 1.4439; 1.4362 acc. EN 10088
Elements made of high corrosion resistant stainless steel	
Threaded rod M8 – M30	Stainless steel HCR $R_m \geq 650$ MPa Acc. EN 10088, 1.4529 / 1.4565
Washer	Stainless steel HCR Acc. EN 10088, 1.4529 / 1.4565
Nut	Stainless steel HCR $R_m \geq 650$ MPa Acc. EN 10088, 1.4529 / 1.4565
ATP Internal Sleeves made of zinc coated steel	
M8 to M20	Carbon steel 11SMnPb30
ATP Internal Sleeves made of stainless steel	
M8 to M16	Stainless steel A4-80 EN 20898-2

SPIT EPOMAX

Material

**Annex 4
 of European Technical Approval
 ETA-05/0111**

Table 2 : Cleaning method and minimum curing time

	Standard cleaning	Premium cleaning
Nominal diameter	All diameters	All diameters
Cleaning method	4 blows+ 4 brushing operation + 4 blows Blowing operation: using a hand pump, blow 4 times. Brushing operation: using the relevant brush, starting from the top of the hole, move downward to the bottom of the hole then move upward to the top of the hole.	2 blows+ 2 brushing operation + 2 blows Blowing operation: using oil free compressed air (mini 6 bars), starting from the bottom of the hole, move upward until no dust is evacuated. Brushing operation: using the relevant brush fitted on a SPIT drilling machine, starting from the top of the hole, move downward to the bottom of the hole (duration 5s) then move upward to the top of the hole (duration 5s)

	Threaded rods							ATP internal sleeves				
Anchor size	M8	M10	M12	M16	M20	M24	M30	M8	M10	M12	M16	M20
Brush diameter [mm]	11	13	15	20	26	30	37	15	22	26	30	37

Ambient temperature	-5°C	0°C	5°C	10°C	20°C	30°C	40°C
Processing time	75mn	22mn	17mn	11mn	6mn	3mn	1mn
Curing time in dry concrete	720mn	210mn	120mn	60mn	40mn	35mn	30mn
Curing time in wet concrete	1440mn	420mn	240mn	120mn	80mn	70mn	60mn

Brush for cleaning the drill hole



SPIT EPOMAX

Cleaning methods

**Annex 5
 of European Technical Approval
 ETA-05/0111**

Instruction For Use: Standard cleaning

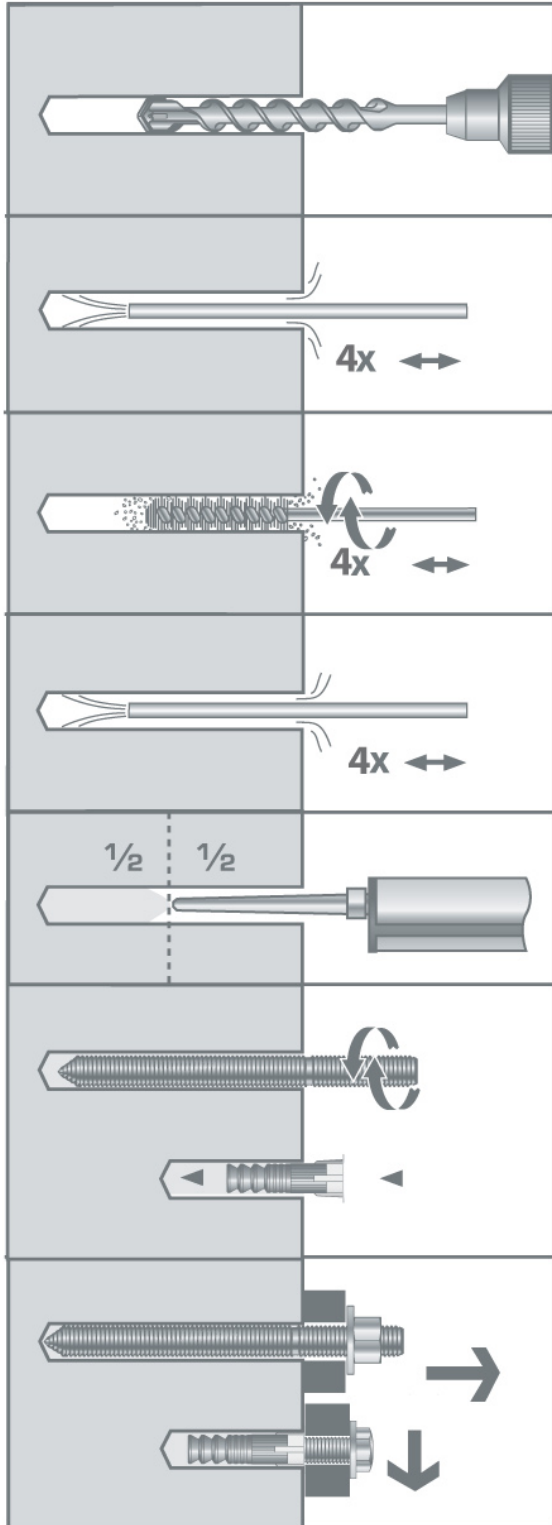

Drill a hole to the correct diameter and depth using a rotary percussive machine.

Starting from the drill hole base blow out at least 4 times with the SPIT hand pump. For the hole diameter 10mm a reduction $\phi 6\text{mm}$ must be clamped on the air pump nozzle.

Using the specified brush, brush out 4 times mechanically

Starting from the drill hole base, blow out at least 4 times with the hand pump

Dispense the first part to waste until an even colour is achieved ($\approx 20\text{cm}$). Insert the nozzle to the far end of the hole, and inject the resin, withdrawing the nozzle as the hole fills. Fill the hole at 50%.

Immediately insert the fixing, slowly and with a slight twisting motion. Remove excess resin from around the mouth of the hole before it sets

Leave the fixing undisturbed until the cure time has elapsed. Attach the fixture and tighten the nut at the required torque.

SPIT EPOMAX

Instruction For Use: Standard cleaning

**Annex 6
of European Technical Approval
ETA-05/0111**

Horizontal installation or downward

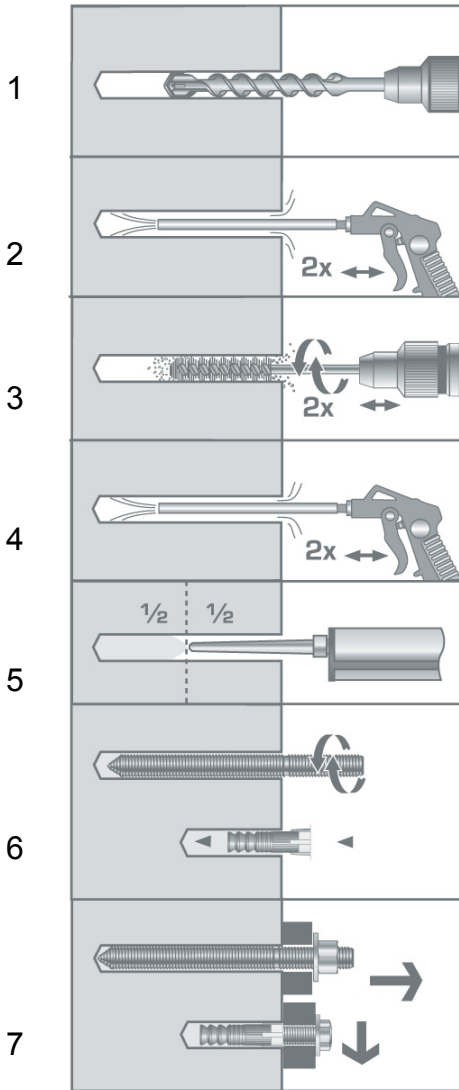

1. Drill a hole to the correct diameter and depth using a rotary percussive machine.
2. Starting from the drill hole base blow out at least 2 times using oil free compressed air (mini 6 bar).
3. using the relevant brush fitted on a SPIT drilling machine, starting from the top of the hole, move downward to the bottom of the hole (duration 5s) then move upward to the top of the hole (duration 5s)
4. Starting from the drill hole base blow out at least 2 times using oil free compressed air.
5. Dispense the first part to waste until an even colour is achieved (\approx 20cm). Insert the nozzle to the far end of the hole, and inject the resin, withdrawing the nozzle as the hole fills. Fill the hole at 50%.
6. Immediately insert the fixing, slowly and with a slight twisting motion. Remove excess resin from around the mouth of the hole before it sets
7. Leave the fixing undisturbed until the cure time has elapsed. Attach the fixture and tighten the nut at the required torque.

Overhead installation

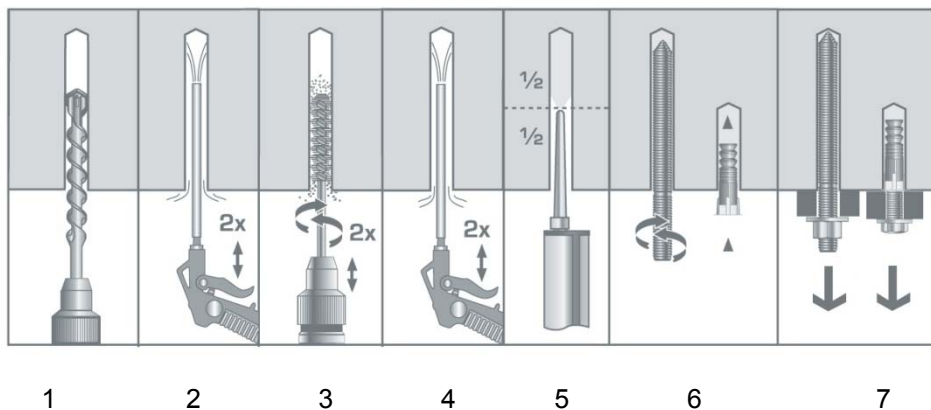

SPIT EPOMAX

Instruction For Use: Premium cleaning

Annex 7

**of European Technical Approval
 ETA-05/0111**

Table 3: Dimensions for threaded rods "S" with helical end

Size	Diameter	Length	Embedment depth					
			$h_{ef, std}$	$t_{fix max}^{1)}$	$h_{ef, min}$	$t_{fix max}^{1)}$	$h_{ef, max}$	$t_{fix max}^{1)}$
M8	8	110	80	15	64	30	95	²⁾
M10	10	130	90	20	80	30	120	²⁾
M12	12	160	110	25	96	40	144	²⁾
M16	16	190	125	35	128	32	192	²⁾
M20	20	260	170	65	160	75	220	²⁾
M24	24	300	210	63	192	80	280	²⁾
M30	30	380	280	70	240	110	330	²⁾

¹⁾ maximum thickness of the fixture only in the case of the specific "S" anchor rod with helical end.

²⁾ Specific "S" anchor rod with helical end cannot be used

Table 4: Installation data for threaded rods

Nominal diameter	$\varnothing d_0$ Nominal diameter of the drill bit [mm]	d_f Clearance hole in the fixture [mm]	h_0 depth of the hole		h_{ef} effective anchoring depth		T_{inst} Tightening torque [N.m]	h_{min} minimum thickness of the concrete slab	
			[mm]		[mm]			[mm]	
			min	max	min	max		min	max
M8	10	9	64	95	64	95	10	100	125
M10	12	12	80	120	80	120	20	110	150
M12	14	14	96	144	96	144	30	125	175
M16	18	18	128	192	128	192	60	165	230
M20	25	22	160	240	160	240	120	210	290
M24	28	26	192	280	192	280	200	250	335
M30	35	33	240	360	240	360	400	310	430

Table 5: Installation data for ATP internal sleeves

Designation	Diameter of thread	Length of the thread	Length of the anchor	External diameter of anchor	Drilling diameter	Depth of the hole	Minimum thickness of the concrete slab	Torque moment
	mm	mm	mm	mm	mm	mm	mm	N.m
ATP M8X60	M8	25	60	12	14	65	100	15
ATP M10X65	M10	32	65	16	20	70	100	30
ATP M12X75	M12	38	75	20	24	80	125	70
ATP M16X125	M16	50	125	22	28	130	180	120
ATP M20X170	M20	63	170	28	35	175	240	200

Table 6 : Minimum spacing and edge distances

			Threaded rods							ATP internal sleeves				
			M8	M10	M12	M16	M20	M24	M30	M8	M10	M12	M16	M20
Minimum spacing	s_{min}	mm	40	45	55	65	85	105	140	40	45	55	65	85
Minimum edge distance	c_{min}	mm	40	45	55	65	85	105	140	40	45	55	65	85

SPIT EPOMAX

Installation data

**Annex 8
 of European Technical Approval
 ETA-05/0111**

Table 7: Characteristic values of resistance to tension loads of design method A

SPIT EPOMAX with threaded rod			M8	M10	M12	M16	M20	M24	M30
Carbon Steel failure									
Characteristic resistance with "S" anchor rod	$N_{Rk,s}$	[kN]	22	35	51	94	118	170	272
Partial safety factor	$\gamma_{Ms}^{1)}$	[-]	1,71				1,49		
Characteristic resistance grade 5.8	$N_{Rk,s}$	[kN]	18	29	42	78	122	177	280
Partial safety factor	$\gamma_{Ms}^{1)}$	[-]	1,50						
Characteristic resistance grade 8.8	$N_{Rk,s}$	[kN]	29	46	67	126	196	282	449
Partial safety factor	$\gamma_{Ms}^{1)}$	[-]	1,50						
Characteristic resistance grade 10.	$N_{Rk,s}$	[kN]	37	58	84	157	245	353	561
Partial safety factor	$\gamma_{Ms}^{1)}$	[-]	1,40						
Stainless Steel failure									
Characteristic resistance grade A4-70	$N_{Rk,s}$	[kN]	26	41	59	110	159	229	261
Partial safety factor	$\gamma_{Ms}^{1)}$	[-]	1,87						2,86
Characteristic resistance HCR	$N_{Rk,s}$	[kN]	24	38	55	102	159	229	365
Partial safety factor	$\gamma_{Ms}^{1)}$	[-]	2,60						
Combined Pull-out and Concrete cone failure ²⁾									
Diameter of threaded rod	d	[mm]	8	10	12	16	20	24	30
Characteristic bond resistance in non-cracked concrete C20/25 for threaded rods									
Temperature range I ³⁾ : -40°C / +40°C	τ_{Rk}	[N/mm ²]	11,0	11,0	11,0	10,0	7,0	7,0	5,5
Temperature range II ³⁾ : -40°C / +80°C	τ_{Rk}	[N/mm ²]	9,0	9,0	9,0	8,0	5,5	5,5	4,5
Temperature range III ³⁾ : -40°C / +120°C	τ_{Rk}	[N/mm ²]	7,0	7,0	7,0	6,0	4,5	4,5	3,5
Increasing factor for τ_{Rkp} in non cracked concrete	ψ_c	C30/37	1,14						
		C40/50	1,26						
		C50/60	1,34						
Splitting failure ²⁾									
Edge distance $c_{cr,sp}$ [mm] for	$h / h_{ef} \geq 2,0$	$1,0 h_{ef}$							
	$2,0 > h / h_{ef} > 1,3$	$4,6 h_{ef} - 1,8 h$							
	$h / h_{ef} \leq 1,3$	$2,26 h_{ef}$							
Spacing	$s_{cr,sp}$	[mm]	$2 c_{cr,sp}$						
Partial safety factor $\gamma_{Mp} = \gamma_{Mc} = \gamma_{Msp}$	Category 1 Dry and wet concrete	Standard cleaning	$1,8^{6)}$						
		Premium cleaning	$1,5^{5)}$						
	Category 2 Dry and wet concrete or flooded holes	Standard cleaning	$1,8^{6)}$						
		Premium cleaning	$1,8^{6)}$	$1,5^{5)}$					

¹⁾ In absence of national regulations

²⁾ Calculation of concrete and splitting, see chapter 4.2.1

³⁾ Explanations, see chapter 1.2

⁴⁾ h_{ef} . effective anchorage depth

⁵⁾ The partial safety factor $\gamma_2 = 1,0$ is included

⁶⁾ The partial safety factor $\gamma_2 = 1,2$ is included

Table 8: Characteristic displacements under axial tension loads [mm/(N/mm²)]

C 20/25 to C50/60 concrete		Threaded rods						
		M8	M10	M12	M16	M20	M24	M30
Temperature range I ³⁾ : 40°C / 24°C	δ_{N0} short term	0,02	0,03	0,03	0,04	0,05	0,06	0,08
	$\delta_{N\infty}$ long term	0,10	0,11	0,13	0,16	0,20	0,23	0,30
Temperature range II & III ³⁾ : 80°C / 50°C & 120°C / 72°C	δ_{N0} short term	0,07	0,08	0,09	0,12	0,14	0,17	0,22
	$\delta_{N\infty}$ long term	0,27	0,32	0,37	0,46	0,56	0,66	0,85

SPIT EPOMAX

Characteristic values under tension loads and displacements for threaded rods

Annex 9

**of European Technical Approval
ETA-05/0111**

Table 9: Characteristic values of resistance to shear loads of design method A

SPIT EPOMAX with threaded rod			M8	M10	M12	M16	M20	M24	M30	
Steel failure without lever arm										
Characteristic resistance with "S" anchor rod	$V_{Rk,s}$	[kN]	11	17	25	47	59	85	136	
Characteristic resistance rod grade 5.8	$V_{Rk,s}$	[kN]	9	15	21	39	61	88	140	
Characteristic resistance rod grade 8.8	$V_{Rk,s}$	[kN]	15	23	34	63	98	141	224	
Characteristic resistance rod grade 10.9	$V_{Rk,s}$	[kN]	18	29	42	78	122	176	280	
Characteristic resistance rod grade A4-70	$V_{Rk,s}$	[kN]	13	20	30	55	79	114	131	
Characteristic resistance rod grade HCR	$V_{Rk,s}$	[kN]	12	19	27	51	80	115	182	
Steel failure with lever arm										
Characteristic resistance with "S" anchor rod	$M^0_{Rk,s}$	[N.m]	22	45	78	200	301	520	1052	
Characteristic resistance rod grade 5.8	$M^0_{Rk,s}$	[N.m]	19	37	65	166	324	561	1124	
Characteristic resistance rod grade 8.8	$M^0_{Rk,s}$	[N.m]	30	60	105	266	519	898	1799	
Characteristic resistance rod grade 10.9	$M^0_{Rk,s}$	[N.m]	37	75	131	333	649	1123	2249	
Characteristic resistance rod grade A4-70	$M^0_{Rk,s}$	[N.m]	26	52	92	233	405	700	1012	
Characteristic resistance rod grade HCR	$M^0_{Rk,s}$	[N.m]	24	49	85	216	422	730	1462	
Partial safety factor steel failure										
"S" anchor rod	γ_{Ms}	[-]	1,43				1,50			
Rod grade 5.8	γ_{Ms}	[-]	1,25							
Rod grade 8.8	γ_{Ms}	[-]	1,25							
Rod grade 10.9	γ_{Ms}	[-]	1,50							
Rod grade A4-70	γ_{Ms}	[-]	1,56					2,38		
Rod grade HCR	γ_{Ms}	[-]	2,17							
Concrete Pry out failure										
Factor in equation (5.7) of technical report TR029 for the design of bonded anchors	k	[-]	2,0 for hef ≥ 60mm							
Partial safety factor	$\gamma_{Mcp}^{1)}$	[-]	1,5 ²⁾							
Concrete edge failure³⁾										
Partial safety factor	$\gamma_{Mc}^{1)}$	[-]	1,5 ²⁾							

¹⁾ In absence of national regulations

²⁾ The partial safety factor $\gamma_2 = 1,0$ is included.

³⁾ Concrete edge failure see chapter 5.2.3.4 of Technical Report TR 029.

Table 10: Characteristic displacements under shear loads

C 20/25 to C50/60 concrete		Threaded rods						
		M8	M10	M12	M16	M20	M24	M30
Admissible service load :V	[kN]	5,9	9,3	13,5	25,2	36,4	52,4	62,2
δ_{V0} short term	[mm]	2,0	2,0	2,0	3,5	3,5	3,5	3,5
$\delta_{V\infty}$ long term	[mm]	3,0	3,0	3,0	5,2	5,2	5,2	5,2

SPIT EPOMAX

Characteristic values under shear loads and displacements for threaded rods

**Annex 10
 of European Technical
 Approval
 ETA-05/0111**

Table 11: Characteristic values of resistance to tension loads of design method A

SPIT EPOMAX with ATP sleeve			M8	M10	M12	M16	M20
Steel failure with ATP internal sleeve + screw grade 5.8							
Characteristic resistance	$N_{Rk,s}$	[kN]	18	29	42	78	122
Partial safety factor	$\gamma_{Ms}^{1)}$	[-]	1,50				
Steel failure with ATP internal sleeve + screw grade 6.8							
Characteristic resistance	$N_{Rk,s}$	[kN]	22	35	51	94	147
Partial safety factor	$\gamma_{Ms}^{1)}$	[-]	1,50				
Steel failure with ATP internal sleeve + screw grade 8.8							
Characteristic resistance	$N_{Rk,s}$	[kN]	29	46	67	110	183
Partial safety factor	$\gamma_{Ms}^{1)}$	[-]	1,50				
Steel failure with ATP internal sleeve A4 + screw A4-70							
Characteristic resistance	$N_{Rk,s}$	[kN]	23	37	54	102	-
Partial safety factor	$\gamma_{Ms}^{1)}$	-	1,86				
Combined Pull-out and Concrete cone failure ²⁾							
Effective anchorage depth	h_{ef}	[mm]	60	65	75	125	170
Effective diameter of anchor	d_1	[mm]	12	16	20	22	28
Characteristic resistance in non-cracked concrete C20/25							
Temperature range I ³⁾ : -40°C / +40°C	$N_{Rk}^{4)}$	[kN]	16	20	30	60	95
Temperature range II ³⁾ : -40°C / +80°C	$N_{Rk}^{4)}$	[kN]	12	16	25	50	75
Temperature range III ³⁾ : -40°C / +120°C	$N_{Rk}^{4)}$	[kN]	9	12	20	35	60
Increasing factor for N_{Rkp} in non cracked concrete	ψ_c	C30/37	1,14				
		C40/50	1,26				
		C50/60	1,34				
Splitting failure ²⁾							
Edge distance	$C_{cr,sp}$	[mm]	90	98	113	188	255
Spacing	$S_{cr,sp}$	[mm]	180	195	225	375	510
Partial safety factor $\gamma_{Mp} = \gamma_{Mc} = \gamma_{Msp}$	Category 2 Dry and wet concrete or flooded holes	Standard cleaning	1,8 ⁶⁾				
		Premium cleaning	1,5 ⁵⁾				

¹⁾ In absence of national regulations

²⁾ Calculation of concrete and splitting, see chapter 4.2.1

³⁾ Explanations, see chapter 1.2

⁴⁾ For design according TR029, the characteristic bond resistance may be calculated from the characteristic tension load values for combined pull-out and concrete cone failure according: $\tau_{Rk} = N_{Rk}/(h_{ef} d_1 \pi)$;

⁵⁾ The partial safety factor $\gamma_2 = 1,0$ is included

⁶⁾ The partial safety factor $\gamma_2 = 1,2$ is included

Table 12: Characteristic displacements under axial tension loads

C 20/25 to C50/60 concrete		ATP internal sleeves				
		M8	M10	M12	M16	M20
Admissible service load :N	[kN]	4,3	5,7	9,5	19,0	35,7
δ_{N0} short term	[mm]	0,1	0,1	0,1	0,2	0,3
$\delta_{N\infty}$ long term	[mm]	0,2	0,2	0,2	0,2	0,3

SPIT EPOMAX

Characteristic resistance under tension loads and displacements for ATP internal sleeves

**Annex 11
 of European Technical Approval
 ETA-05/0111**

Table 13: Characteristic values of resistance to shear loads of design method A

SPIT EPOMAX with ATP sleeve			M8	M10	M12	M16	M20
Steel failure without lever arm							
Char. resistance ATP + Screw grade 5.8	$V_{Rk,s}$	[kN]	9	15	21	39	61
Char. resistance ATP + Screw grade 6.8	$V_{Rk,s}$	[kN]	11	17	25	47	74
Char. resistance ATP + Screw grade 8.8	$V_{Rk,s}$	[kN]	15	23	34	55	91
Char. resistance ATP A4 + Screw grade A4-70	$V_{Rk,s}$	[kN]	11	18	27	51	-
Steel failure with lever arm							
Char. resistance ATP + Screw grade 5.8	$M^0_{Rk,s}$	[N.m]	19	37	65	166	324
Char. resistance ATP + Screw grade 6.8	$M^0_{Rk,s}$	[N.m]	22	45	79	200	389
Char. resistance ATP + Screw grade 8.8	$M^0_{Rk,s}$	[N.m]	30	60	105	266	519
Char. resistance ATP A4 + Screw grade A4-70	$M^0_{Rk,s}$	[N.m]	22	45	80	208	-
Partial safety factor							
Screw grade 5.8	γ_{Ms}	-	1.25				
Screw grade 6.8	γ_{Ms}	-	1.25				
Screw grade 8.8	γ_{Ms}	-	1.25	1.50			
Screw grade A4-70	γ_{Ms}	-	1.56				
Concrete Pry out failure							
Factor in equation (5.7) of technical report TR029 for the design of bonded anchors	k	-	2,0 for hef ≥ 60mm				
Partial safety factor	γ_{Mcp}	-	1,5 ²⁾				
Concrete edge failure³⁾							
Partial safety factor	γ_{Mc} ¹⁾	[-]	1,5 ²⁾				

¹⁾ In absence of national regulations

²⁾ The partial safety factor $\gamma_2 = 1,0$ is included.

³⁾ Concrete edge failure see chapter 5.2.3.4 of Technical Report TR 029.

Table 14: Characteristic displacements under shear loads

C 20/25 to C50/60 concrete		ATP sleeve				
		M8	M10	M12	M16	M20
Admissible service load :V	[kN]	4.3	5.7	9.5	19.0	35.7
δ_{V0} short term	[mm]	0.1	0.1	0.1	0.2	0.3
$\delta_{V\infty}$ long term	[mm]	0.2	0.2	0.2	0.2	0.3

SPIT EPOMAX

Characteristic values under shear loads and displacements for ATP internal sleeves

**Annex 12
 of European Technical Approval
 ETA-05/0111**