

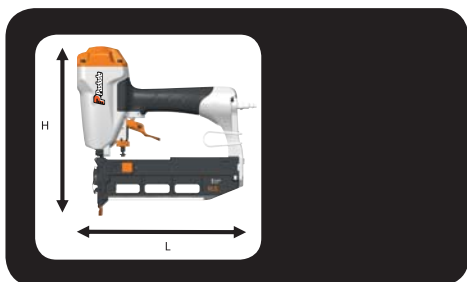

**Paslode®**

**FN1665.2**





## FN1665.2



		<p>A = 295 mm</p> <p>B = 314 mm</p> <p>C = 74 mm</p>
		= 1.8 kg

<p>Min. 5,5 bar</p> <p>Max 8,3 bar</p>
<p>0,7 l (6 bar) / </p>
<p>Ps max. = 8,3 bar</p>

<p>EN 12549+EN ISO 4871</p>	<p>L<sub>WA.1s</sub> = 100 dBA</p> <p>L<sub>pA.1s</sub> = 90 dBA</p> <p>L<sub>pA.1s1m</sub> = 87 dBA</p>
	<p>EN 12096 : 1997</p> <p>ISO 8662-11</p>
<p>Vibration</p>	<p>= 1,8 m/s<sup>2</sup></p>

<p>85 x = </p>	
	<p>D = 2,9 mm</p> <p>d = 1,36 x 1,6 mm</p> <p>L = 25 - 65 mm</p>



	<p>Sequential trigger actuation/ Einzelauslösung/ enkelschots/ Déclenchement du tir - mode séquentiel/ Funcionamiento secuencial "en continuo"/ Gatilho de actuação sequencial/ funzionamento sequenziale (colpo a colpo)/ Enkeltskuds aftrækker/ Enkelskott/ Enkeltskudds avtrekker/ Kertalaukaisu/ Üksiklasu meetodil töötamine/ Uruchomienie spustu sekwencyjne/ Sekvenční spoušť/ Egyes lövés (szakaszosan működtetett elsütő billentyűvel)/ Posamezno proženje/ Kontaktirajte singl / Последовательная активация при нажатии на курок/ Sekvenčná aktivácia spúšte/ التشغيل بالزر التسلسلي المقيد / Nuoseklusis paleidimo mechanizmas/ Sekvenciālās palaišanas iedarbināšana Raðkveikjувirkjun</p>
	<p>Contact trigger actuation/ Kontaktauslösung/ repeterend schieten/ Déclenchement du tir - mode rafale/ Funcionamiento por contacto "clavo a clavo"/ Gatilho de actuação por contacto/ funzionamento a contatto/ Stødskydnings aftrækker/ Støtskjutning/ Støtspikrings avtrekker/ Kosketuslaukaisu/ Automaatmeetodil töötamine/ Uruchomienie spustu przez kontakt/ Kontaktní spoušť/ Sorozatlövés (folyamatosan behúzott elsütő billentyűvel)/ Kontaktno proženje/ Kontaktirajte pokretanje/ Контактная активация при нажатии на курок/ Kontaktná aktivácia spúšte/ التشغيل بتلامس الزر / Kontaktinis paleidimo mechanizmas/ Kontakta palaišanas iedarbināšana/ Snertikveikjувirkjun</p>

<p><b>Model: FN1665.2 Selectable</b> <b>No. 650412</b></p>			
			
			
<p>No. 014748</p>	<p>No. 577033</p>	<p>No. 617244</p>	

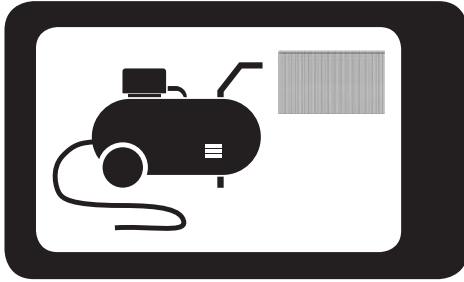

014 748

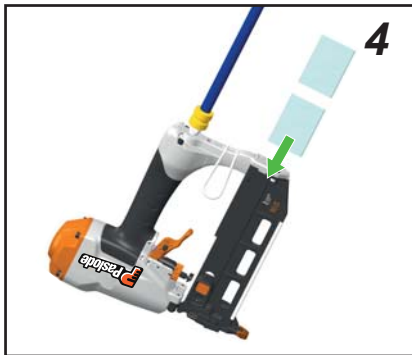
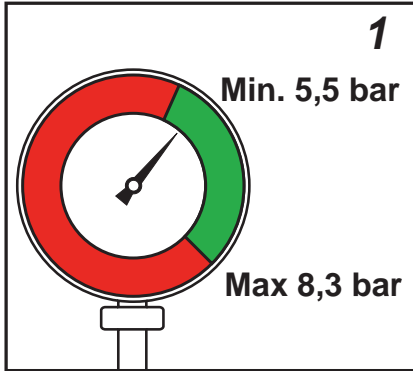

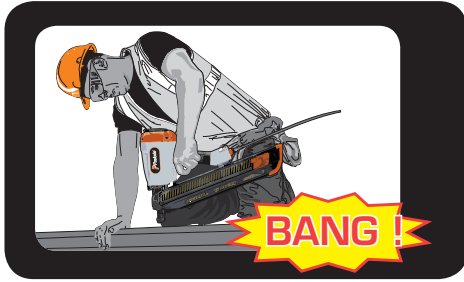

014 748

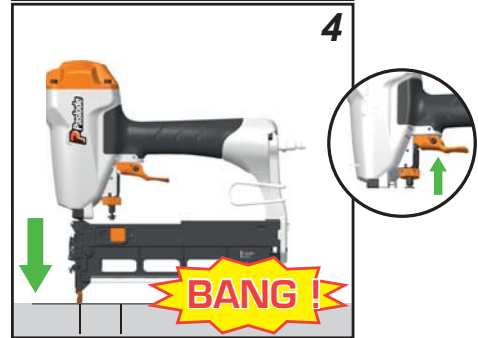
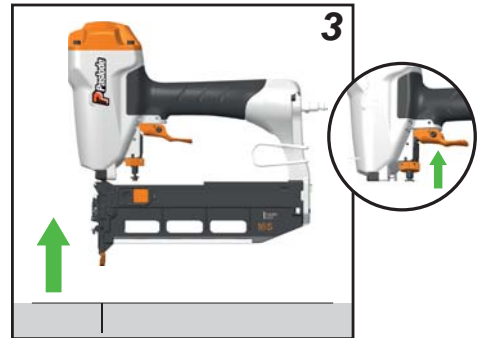
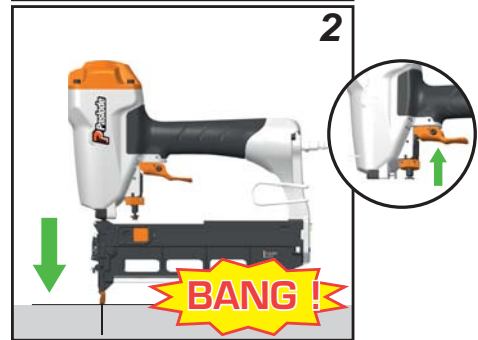
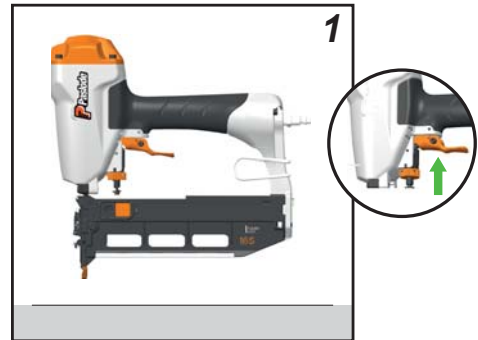
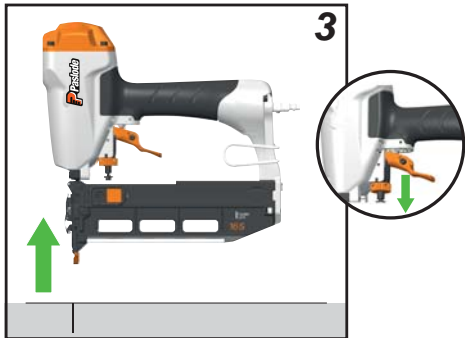
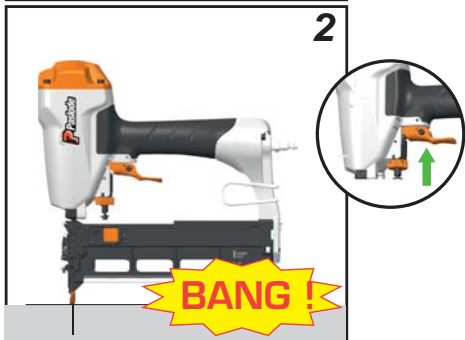
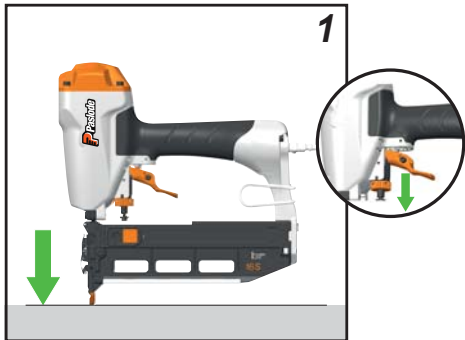

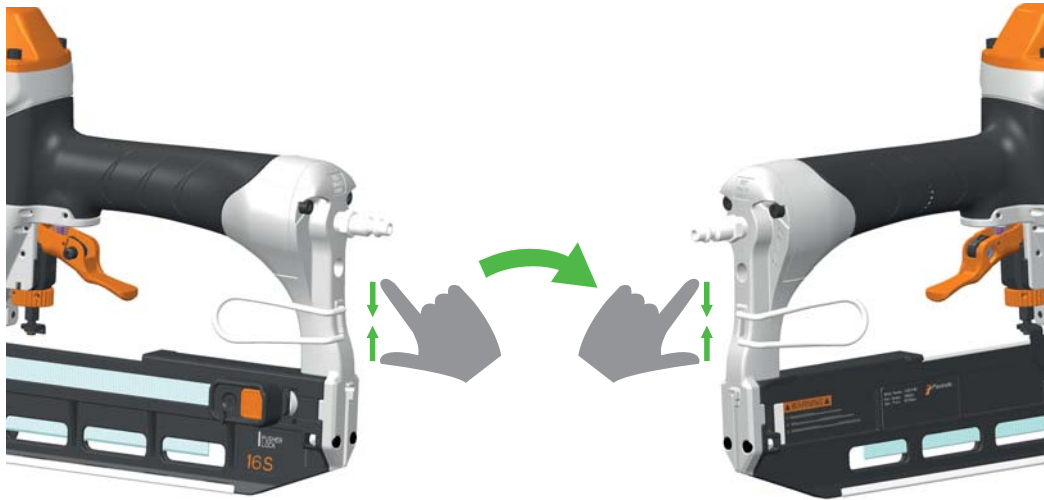
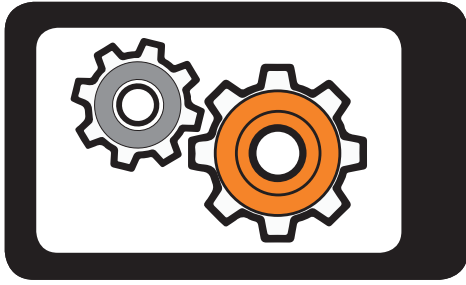

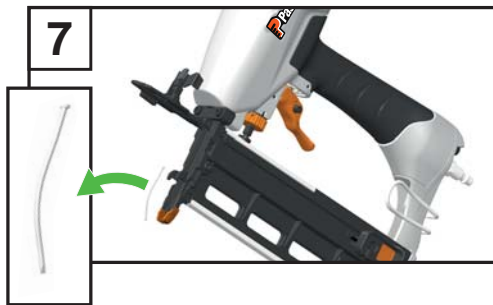
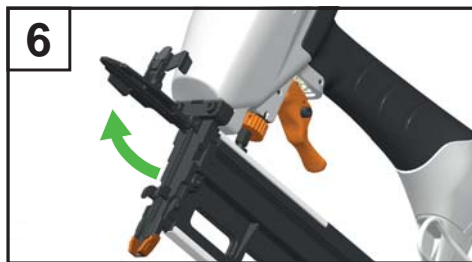
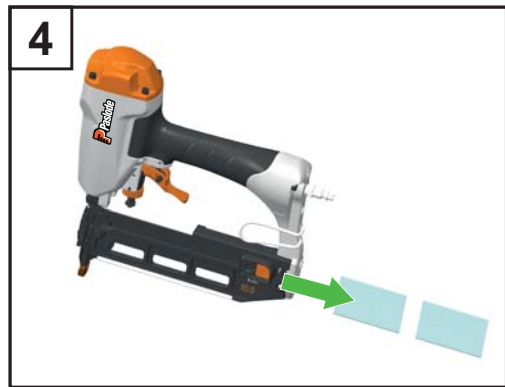
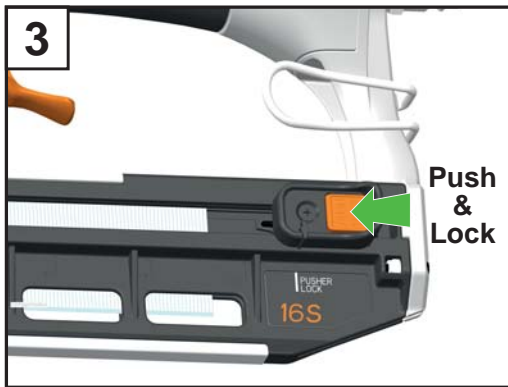
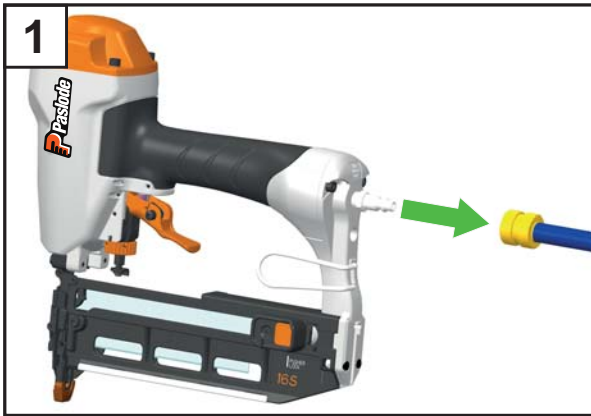
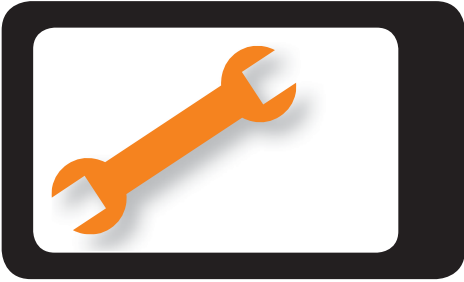

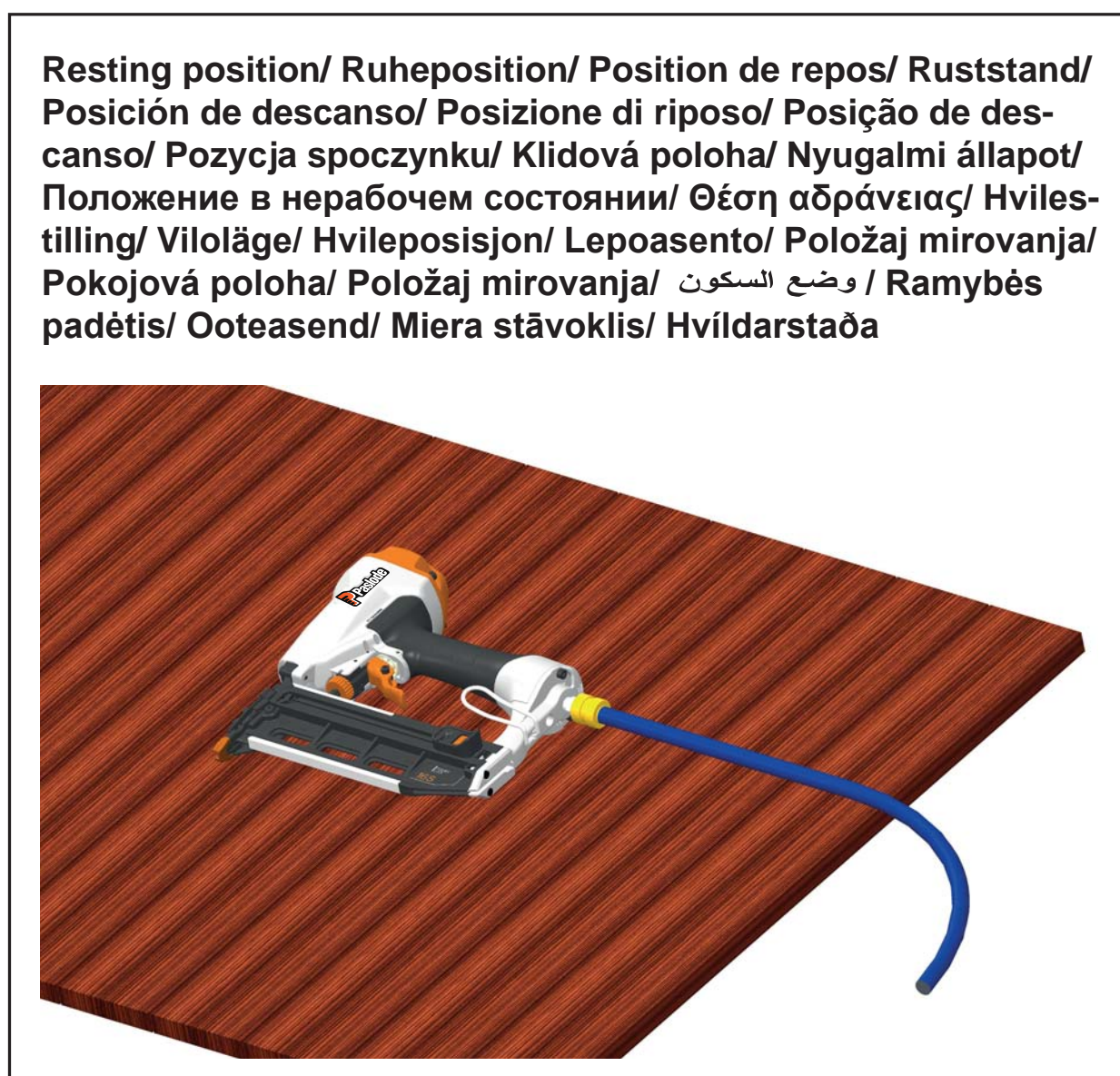



# FN1665.2 605412

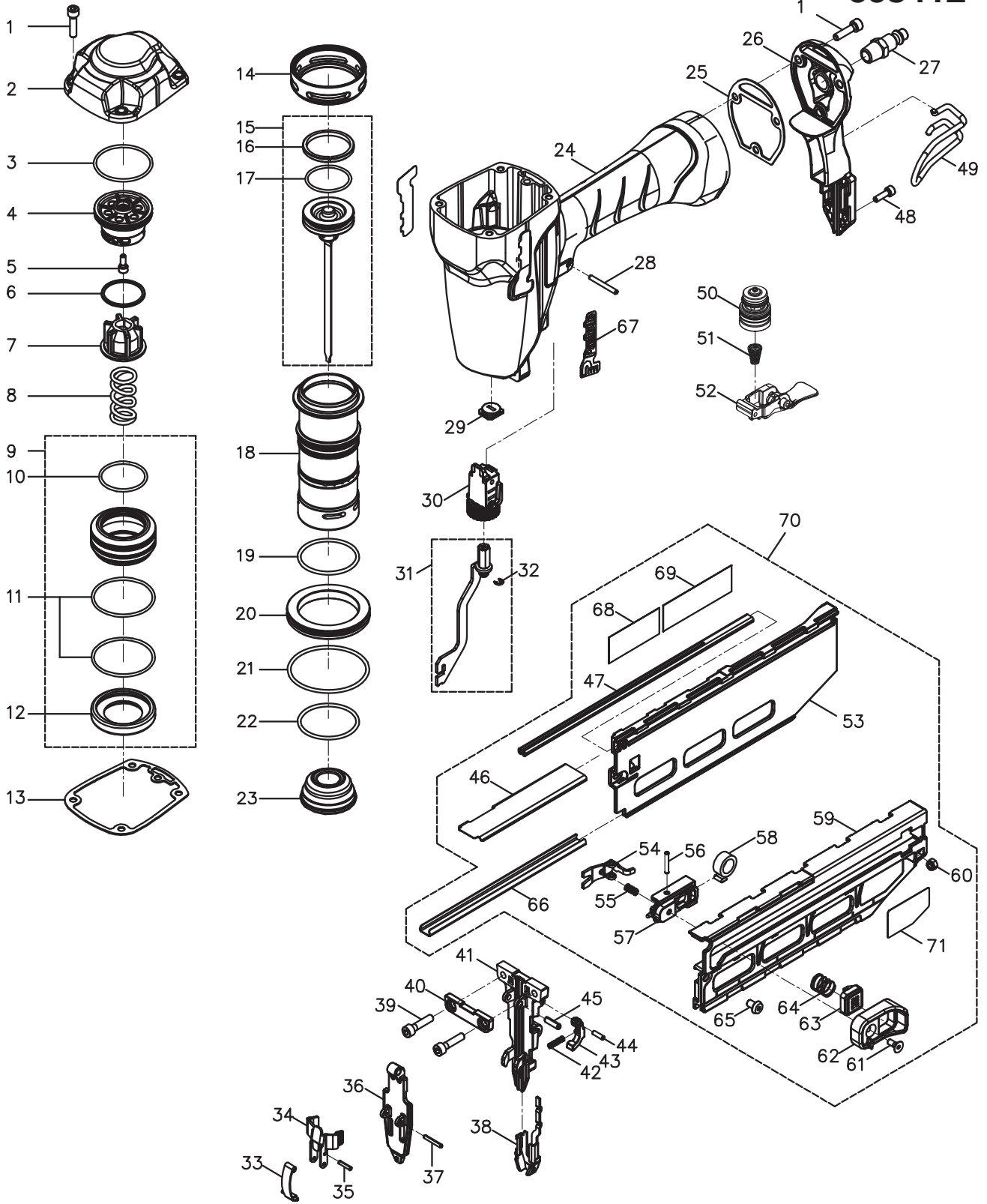

# FN1665.2 605412

N°	Code	Qty	Name	N°	Code	Qty	Name
1	515501	7	Hex. Soc. Hd. Bolt	37	515537	1	Spring Pin
2	515502	1	Cap	38	515538	1	WCE
3	515503	1	O-Ring	39	515539	2	Hex. Soc.Hd. Bolt
4	515504	1	Top Cap Ring	40	515540	1	Set Plate
5	515505	1	Hex. Soc. Hd. Bolt	41	577030	1	Nose
6	515506	1	Spacer	42	617456	1	Spring
7	515507	1	Piston Stopper	43	515543	1	Lock-out Lever
8	515508	1	Spring	44	515544	1	Spring Pin
9	515509	1	Head Valve Assembly	45	515545	1	Spring Pin
10	515510	1	O-Ring	46	515546	1	Upper Plate
11	515511	2	O-Ring	47	515547	1	Nail Guide
12	515512	1	Seal	48	515548	2	Hex. Soc.Hd. Bolt
13	515513	1	Top Cap Seal	49	515549	1	Belt Hook
14	515514	1	Collar	50	515550	1	Trigger Valve Assembly
15	515515	1	Driver Blade Assembly	51	617780	1	Spring
16	515516	1	Wear-Ring	52	515552	1	Selectable Trigger
17	515517	1	O-Ring	53	515553	1	Magazine (Right)
18	515518	1	Cylinder	54	515554	1	Pusher
19	515519	1	O-Ring	55	515555	1	Spring
20	515520	1	Cylinder-Ring	56	515556	1	Spring Pin
21	515521	1	O-Ring	57	515557	1	Pusher Seat Assembly
22	515522	1	O-Ring	58	515558	1	Roll Spring
23	515523	1	Bumper	59	515559	1	Magazine (Left)
24	515524	1	Housing	60	515560	2	Lock Nut
25	515525	1	End Cap Seal	61	515561	1	Flat self-tapping Bolt
26	577028	1	End Cap	62	515562	1	Pusher Upper seat
27	577029	1	Air Plug	63	515563	1	Push Button
28	515528	4	Spring Pin	64	515564	1	Spring
29	515529	1	Bumper Seal	65	515565	2	UM. HD. Bolt
30	515530	1	Depth of Drive A	66	515566	1	Lower Plate
31	515531	1	WCE Connector	67	515567	2	Logo Label
32	403713	1	E-Ring	68	577031	1	Warning Label
33	515533	1	Latch Spring Assembly	69	577032	1	Model Label
34	515534	1	Latch	70	515570	1	Magazine Assembly
35	515535	1	Spring Pin	71	515571	1	Lock Label
36	515536	1	Door				

## GB DECLARATION OF CONFORMITY

FR DECLARATION DE CONFORMITE DE KONFORMITÄTSEKTLÄRUNG ES DECLARACIÓN DE CONFORMIDAD  
PT DECLARAÇÃO DE CONFORMIDADE IT DICHIARAZIONE DI CONFORMITÀ NL CONFORMITEISVERKLARING  
DK OVERENSSTEMMELSESEKTLÆRING SE KONFORMITETSDEKLARATION NO SAMSVARSEKTLÆRING FI  
FI YHDENMUKAISUUSILMOITUS PL DEKLARACJA ZGODNOŚCI CZ PROHLÁŠENÍ O SHODĚ HU PROHLÁŠENÍ O SHODĚ  
GR ΔΗΛΩΣΗ ΣΥΜΜΟΡΦΩΣΗΣ RU ДЕКЛАРАЦИЯ СООТВЕТСТВИЯ ET VASTAVUSDEKLARATSIOON  
LT ATITIKTIES DEKLARACIJA LV ATBILSTĪBAS DEKLARĀCIJA HR POLOŽAJ MIROVANJA SK VYHLÁSENIE O ZHODE  
VB IZJAVA O SKLADNOSTI AR وضع السكون ISL YFIRLÝSING UM SAMRÆMI

## PNEUMATIC TOOLS

ITW Befestigungssysteme GmbH  
Carl - Zeiss - Straße 19  
30966 HEMMINGEN - Germany

VALENCE, le 23/11/17

 Jim HABERSTROH  
(Engineering Director, GTU)

GB	We declare that this product conforms with the standard or other standard documents. In accordance with the provisions of the EC Directives.
FR	Nous déclarons que ce produit est conforme aux normes ou autres documents normatifs. Conformément aux dispositions des Directives CE.
DE	Wir bestätigen, dass dieses Produkt den Normen bzw. sonstigen Regelwerken entspricht. Gemäß den Bestimmungen der EC-Richtlinien.
ES	Declaramos que este producto se conforma a las normas u otros documentos normativos. Conforme a lo establecido por las Directivas CE.
PT	Declaramos que este produto obedece às normas ou a outros documentos normativos. De acordo com as disposições das Directivas EC.
IT	Si dichiara che questo prodotto è conforme alle norme ovvero agli altri documenti normativi. In conformità alle disposizioni delle Direttive C.E.
NL	Wij verklaren dat dit product conform is met de normen en andere normatieve documenten. Conform met de bepalingen van de EEG-Richtlijnen.
DK	Erklærer vi, at dette produkt er i overensstemmelse med standarder og øvrige normative dokumenter. I henhold til bestemmelserne i EØF-direktiverne.
SE	Vi deklarerar att denna produkt är i överensstämmelse med standarderna och andra normativa dokument. Enligt bestämmelserna i EG-Direktiven.
NO	Vi erklærer at dette produktet er i overensstemmelse med alle standarder og normer. I overensstemmelse med EØF-direktivene.
FI	Ilmoitamme, että tämä tuote noudattaa normeja tai muita normatiivisia asiakirjoja. EC-direktiivien määräysten mukaisesti.
PL	Oświadczamy, że produkt jest zgodny z normami lub innymi dokumentami normatywnymi. Zgodnie z przepisami dyrektyw EC.
CS	Prohlašujeme, že tento výrobek je v souladu s normami či jinými normativními dokumenty. V souladu s ustanoveními směrnice EC.
HU	Kijelentjük, hogy ez a termék megfelel a szabványoknak és egyéb normatív dokumentumoknak. Az EKG irányelvekkel összhangban.
GR	Δηλώνουμε ότι το παρόν προϊόν συμφωνεί με τα πρότυπα και τα υπόλοιπα έγγραφα τυποποίησης. Σύμφωνα με τις διατάξεις των Οδηγιών ΕΟΚ.
RU	Мы заявляем, что это изделие соответствует нормам или другим нормативным документам. В соответствии с распоряжениями Директив ЕС.
ET	Käesolevaga kinnitame, et see toode vastab standardile või teistele standarddokumentidele EÜ direktiivi sätete kohaselt.
LT	Mes pareiškiame, jog šis produktas atitinka normas ir kitus normatyvinius dokumentus. Atitinka EB direktyvų nuostatas.
LV	Mēs paziņojam, ka šis izstrādājums atbilst standartam vai citiem standarta dokumentiem. Saskaņā ar EK direktīvas noteikumiem.
HR	Izjavljujemo da je ovaj proizvod u skladu sa standardom ili drugim standardnim dokumentima. U skladu s odredbama direktiva EU.
SK	Vyhlasujeme, že tento výrobok je v súlade s normou alebo inými štandardnými dokumentmi. V súlade s ustanoveniami smerníc EÚ.
VB	Izjavljamo, da je ta izdelek skladen s standardi ali drugimi standardnimi dokumenti. V skladu z določbami direktiv EU.
AR	نصرح ونعلن أن هذا المنتج مطابق لوثائق المعايير أو وثائق المعايير الأخرى طبقاً لنصوص توجيهات الاتحاد الأوروبي .
ISL	Við staðfestum að vara þessi uppfyllir staðlana eða önnur stöðluð gögn í samræmi við ákvæði tilskipana ESB.

ISO 11148-13 : 2017 - 2006/42/EC



ITW CONSTRUCTION PRODUCTS EUROPE  
Code 577033 (11/2017)  
[www.spitpaslode.com](http://www.spitpaslode.com)