

TLG-G

Sirkulær ventil for tilluft og avtrekk

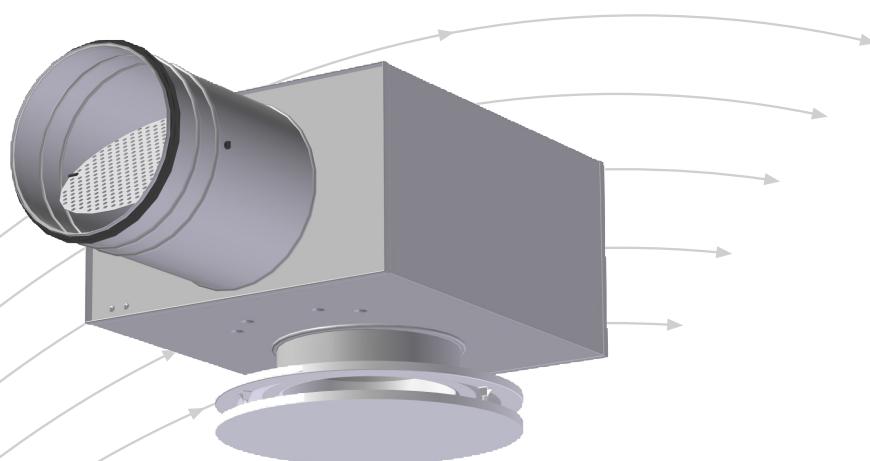

- Sirkulær ventil for tilluft og avtrekk
- Justerbar spaltehøyde
- Lavtbyggende
- Dokumentert med Luna plenumskammer
- Lydabsorbent i polyester i kammer
- Dimensjonering og simulering i AURASIM

TROX[®] TECHNIK

 **Auranor**

TROX Auranor Norge AS

Postboks 100
2712 Brandbu

Telefon +47 61 31 35 00
e-post: firmapost@auranor.no
www.trox.no

TLG-G

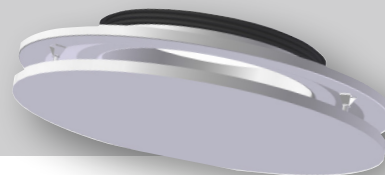

ANVENDELSE

TLG-G er en sirkulær ventil for montasje i fast himling. Ventilen kan brukes som tilluft og avtrekk. TLG-G er designet for å utnytte Coanda-effekten mot takflaten og egner seg for både konstant og variable luftmengder.

UTFØRELSE

TLG-G har demonterbar frontplate og justerbar spaltehøyde.

MATERIALE OG OVERFLATEBEHANDLING

Ventilen er produsert i stål og anslutningen har påmontert EPDM gummipakning. TLG-G er lakkert i RAL 9003 - glans 30. Andre farger kan leveres på forespørsel.

HURTIGVALG

Hurtigvalg TLG-G i kanal (tilluft)

Dim.	[m ³ /h]		
	25 dB(A)	30 dB(A)	35 dB(A)
100	94	114	137
125	156	185	221
160	236	277	324
200	315	364	421
250	482	560	651
315	485	572	675

Tabell 1, viser luftmengder ved oppgitt lydeffektnivå, maksimal spaltehøyde og ventil montert direkte i rett kanal.

Hurtigvalg TLG-G i kanal (avtrekk)

Dim.	[m ³ /h]		
	25 dB(A)	30 dB(A)	35 dB(A)
100	109	130	154
125	201	238	282
160	303	357	420
200	410	482	567
250	751	890	1054
315	893	1066	1272

Tabell 2, viser luftmengden ved angitt lydeffektnivå, maksimal spaltehøyde.

BESTILLINGSKODE, TLG-G

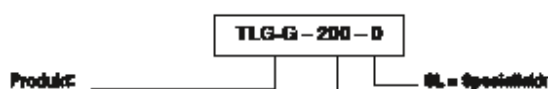

Dimensjon #100 - Ø315

Eksempel:
TLG-G-200-0

Forklaring:

TLG-G, dimensjon Ø200, lakkert standard RAL 9003 - glans 30

MÅL OG VEKT, TLG-G

Dim.	A	B	J	T	Utsp. mål	Vekt ventil [kg]
100	209	99	44	34-45	110	0,7
125	238	124	44	34-45	135	0,9
160	279	159	44	35-50	170	1,1
200	334	199	44	35-50	210	1,4
250	419	249	44	35-60	260	2,1
315	525	314	44	35-60	325	3,0

Tabell 3

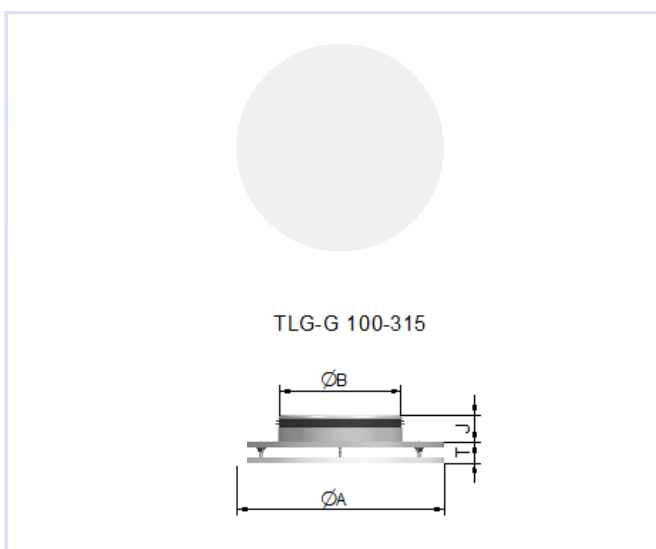

Figur 1, målskisse TLG-G

BESTILLINGSKODE, Luna

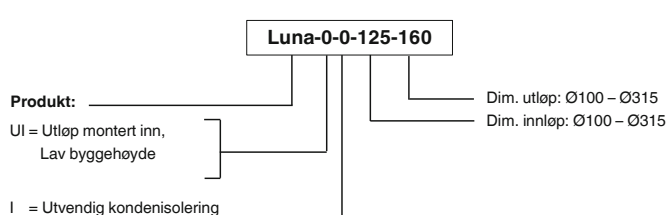

Eksempel:

Luna-0-0-125-160

Forklaring:

Luna med innløp Ø125 og utløp Ø160

TLG-G med Luna plenumskammer

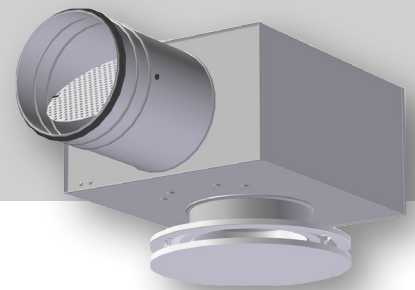

ANVENDELSE

Luna plenumskammer anbefales benyttet for å gi bedre lydemping, samt regulerings- og målemulighet. Luna er et rektangulært kammer med demonterbart spjeld som gir tilgang til anslutningskanal. Spjeldet låses i ønsket posisjon.

UTFØRELSE

Plenumskammeret Luna har spjeld og måleuttak for innregulering. Kammeret er isolert med en lydabsorbent i polyester og kan leveres med én eller to dimensjonsforandringer mellom inn- og utløp. Kammeret kan også leveres med utvendig kondensisolering [I]. **Lavbyggende utførelse [UI]** er også tilgjengelig, denne utførelsen gir en kapasitetsreduksjon på ca. 20 %. Avstanden mellom ventil og kammer kan økes med inntil 35 cm uten at vaier og måleslange må forlenges.

HURTIGVALG TLG M/LUNA

TLG-G Dim.	Luna Dim.	Luftmengde m ³ /h		
		25 dB(A)	30 dB(A)	35 dB(A)
100	100-100	75	86	100
125	100-125	79	112	155
160	100-160	65	119	180
125	125-125	101	130	162
160	125-160	90	137	205
200	125-200	72	144	270
160	160-160	154	198	241
200	160-200	162	234	324
250	160-250	155	241	342
200	200-200	212	266	324
250	200-250	234	310	403
315	200-315	216	316	468
250	250-250	331	398	470
315	250-315	338	432	563
315	315-315	414	522	620

Tabell 4, tabellen viser luftmengde ved 50 Pa totaltrykktap, maksimal spaltehøyde, tilluft.

TLG-G Dim.	Luna Dim.	Luftmengde m ³ /h		
		25 dB(A)	30 dB(A)	35 dB(A)
125	100-125	83	122	162
160	100-160	61	97	162
160	125-160	94	148	241
200	125-200	83	126	216
200	160-200	173	281	349
250	160-250	180	252	353
250	200-250	274	385	522
315	200-315	238	349	482
315	250-315	396	529	720
315	315-315	590	770	990

Tabell 4, tabellen viser luftmengden ved 50Pa totaltrykktap, maksimal spaltehøyde, avtrekk

MATERIALE OG OVERFLATEBEHANDLING

Luna leveres i galvanisert utførelse, innvendig isolert i fire sider med en lydabsorbent i polyester. Anslutningen har EPDM gummipakning.

MÅL OG VEKT, Luna

Dim.	D	DA	B	H	H1	H2	L	L1	L2	Vekt (kg) m/Luna
100-100	99	102	220	122	180	58	325	292	127	2,3
100-125	99	127	220	122	180	58	325	292	127	2,3
100-160	99	162	220	122	180	58	360	309	145	2,4
125-125	124	127	250	147	205	58	360	334	145	2,4
125-160	124	162	250	147	205	58	360	334	145	2,9
125-200	124	202	250	147	205	58	400	354	165	3,1
160-160	159	162	340	182	240	58	403	390	167	4,1
160-200	159	202	340	182	240	58	403	390	167	4,2
160-250	159	252	340	182	240	58	453	415	192	4,6
200-200	199	202	380	222	280	58	453	457	190	5,7
200-250	199	252	380	222	280	58	453	457	190	5,7
200-315	199	317	380	222	280	58	515	487	222	6,1
250-250	249	252	390	272	330	58	515	537	222	7,4
250-315	249	317	390	272	330	58	515	537	222	7,4
315-315	314	317	500	337	395	58	600	654	255	11

Tabell 6, mål og vekt Luna

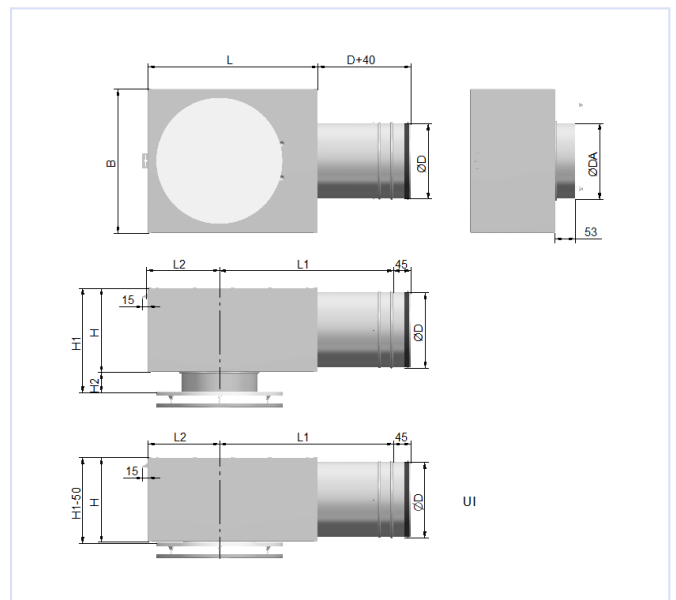

Figur 2, målskisse TLG-G med Luna

TLG-G

AKUSTISK DOKUMENTASJON

I diagrammene er det oppgitt summert A-veid lydeffektnivå fra ventil, L_{WA}. Korreksjonsfaktorene i tabell 8, side 17, benyttes for å beregne avgitt frekvensfordelt lydeffektnivå, L_W = L_{WA} + KO. Lydtrykknivå i et rom med absorpsjon tilsvarende 10m² Sabine vil være 4 dB lavere enn avgitt lydeffektnivå.

Eksempel:

TLG-G med Luna 125-125 og minimum spaltehøyde, ønsket luftmengde 35 l/s.

Av diagram 10 finner vi at L_{WA} = 31 dB(A) ved åpent spjeld og 28 Pa totaltrykktap. Vi ønsker å finne følgende data:

- avgitt lydeffektnivå i 250 Hz
- A-veid lydtrykknivå i et kontor
- A-veid lydtrykknivå i et kontor ved 50 Pa totaltrykktap, (dvs. 22 Pa struping over enhetens spjeld.)

- Korreksjonsfaktoren er 0 dB. Avgitt lydeffektnivå i 250 Hz blir da: L_W = L_{WA} + KO = 31 + (0) = **31 dB**
- Hvis vi forutsetter romabsorpsjon tilsvarende 10m² Sabine, blir A-veid lydtrykknivå: 31 - 4 = **27 dB(A)**
- Ved å følge linjen for 35 l/s i diagrammet opp til 50 Pa, avleses 31 dB(A) = ingen økning, det vil si at A-veid lydtrykknivå blir **27 dB(A)**

DIMENSJONERINGSDIAGRAM, TILLUFT

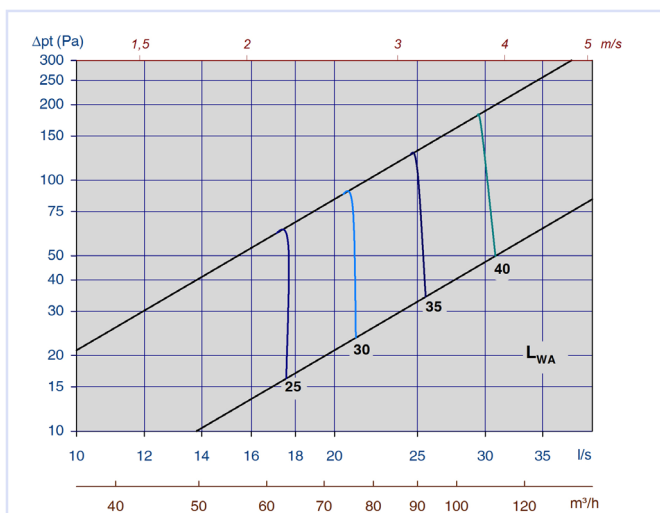

Diagram 1: TLG-G m/Luna 100-100 min. spalt, tilluft

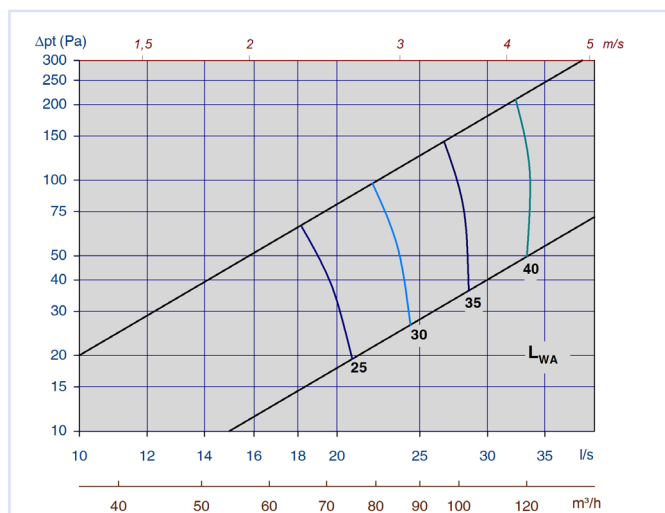

Diagram 2: TLG-G m/Luna 100-100 midt. spalt, tilluft

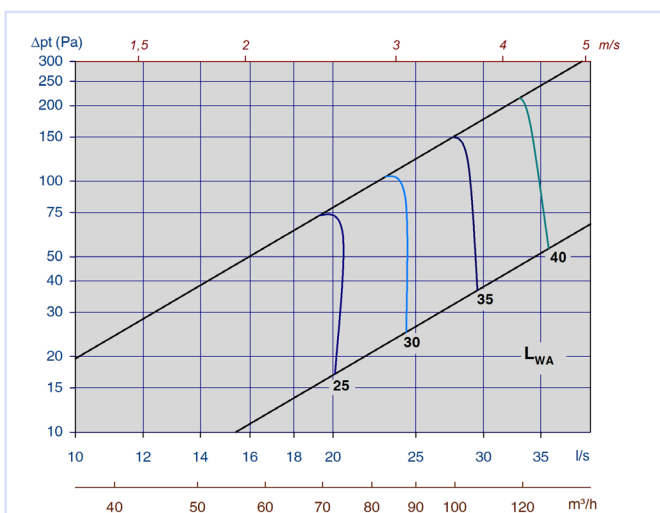

Diagram 3: TLG-G m/Luna 100-100 maks. spalt, tilluft

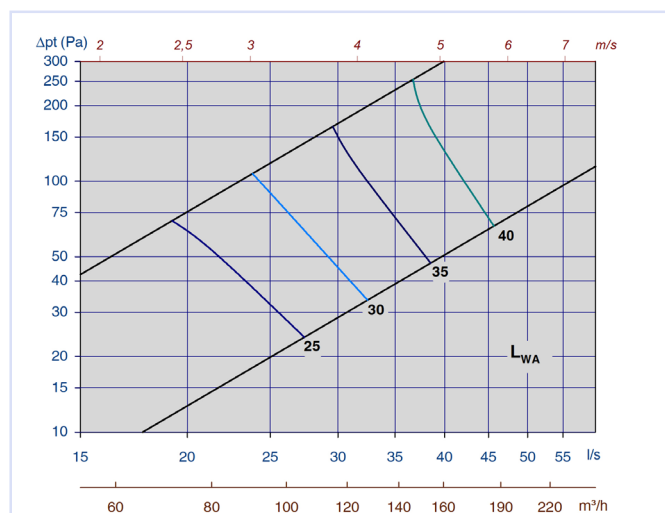

Diagram 4: TLG-G m/Luna 100-125 min. spalt, tilluft

TLG-G

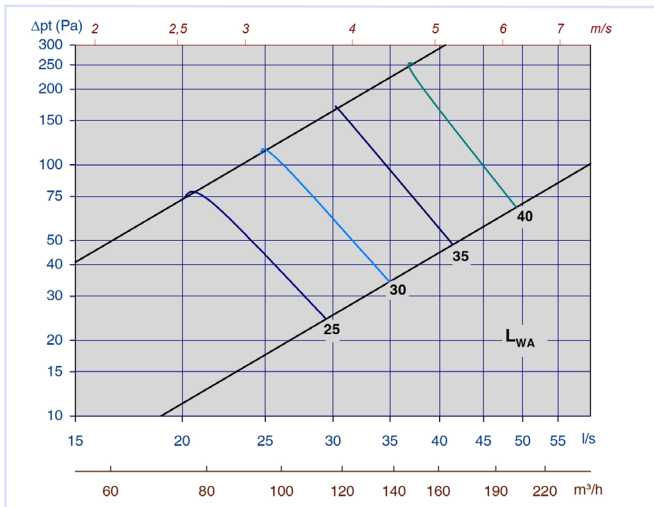

Diagram 5: TLG-G m/Luna 100-125 midt. spalt, tilluft

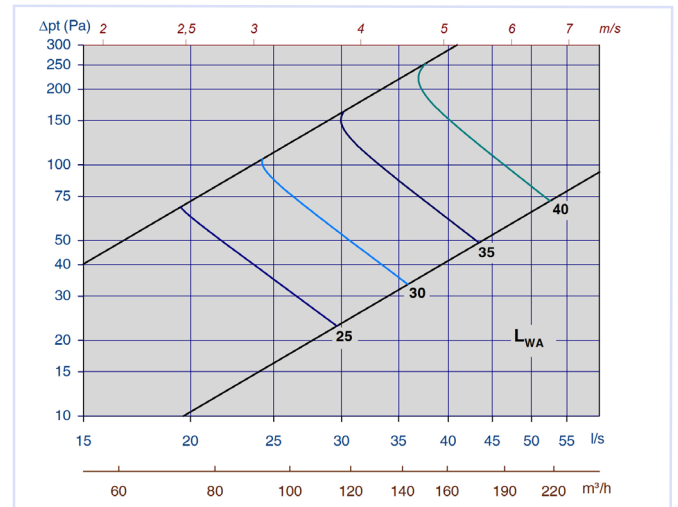

Diagram 6: TLG-G m/Luna 100-125 maks. spalt, tilluft

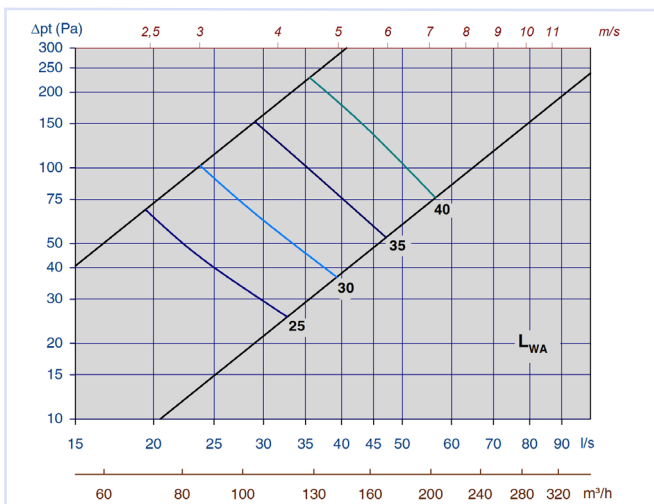

Diagram 7: TLG-G m/Luna 100-160 min. spalt, tilluft

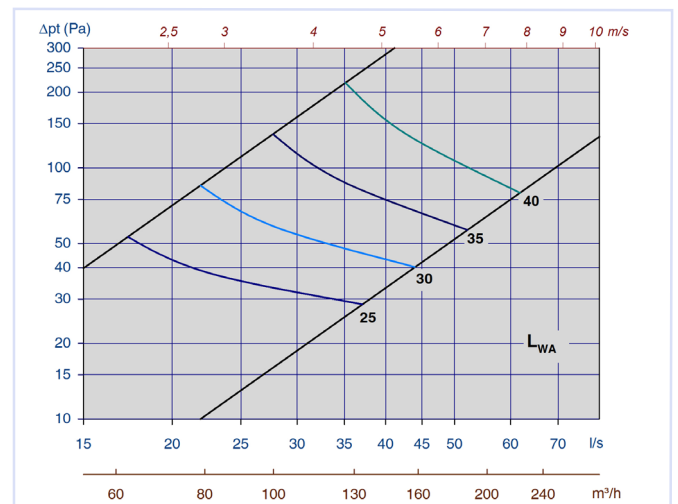

Diagram 8: TLG-G m/Luna 100-160 midt. spalt, tilluft

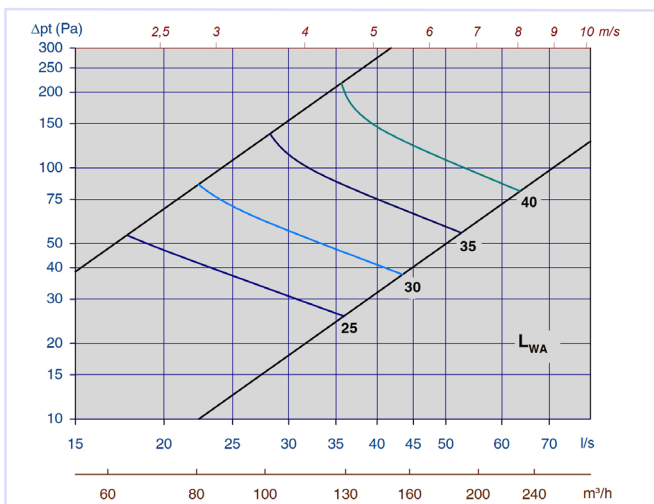

Diagram 9: TLG-G m/Luna 100-160 maks. spalt, tilluft

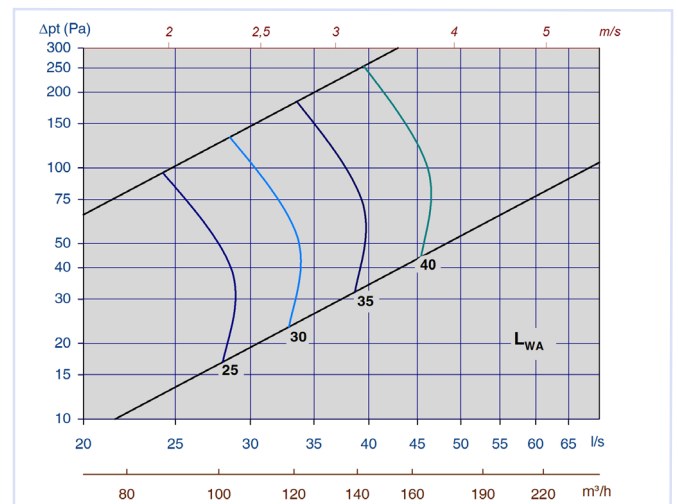

Diagram 10: TLG-G m/Luna 125-125 min. spalt, tilluft

TLG-G

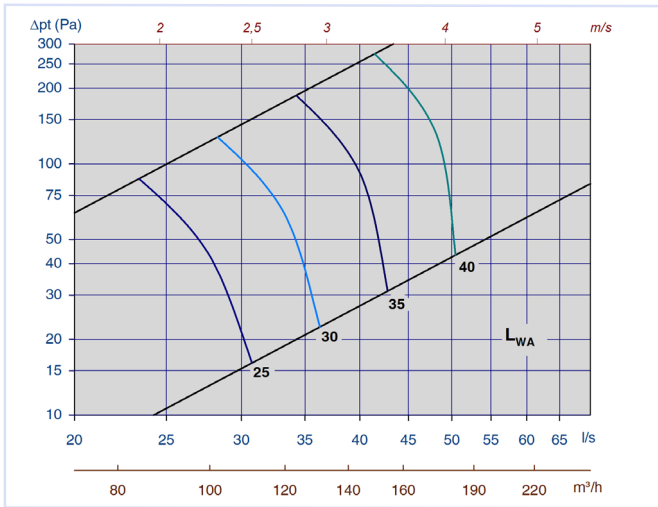

Diagram 11: TLG-G m/Luna 125-125 midt. spalt, tilluft

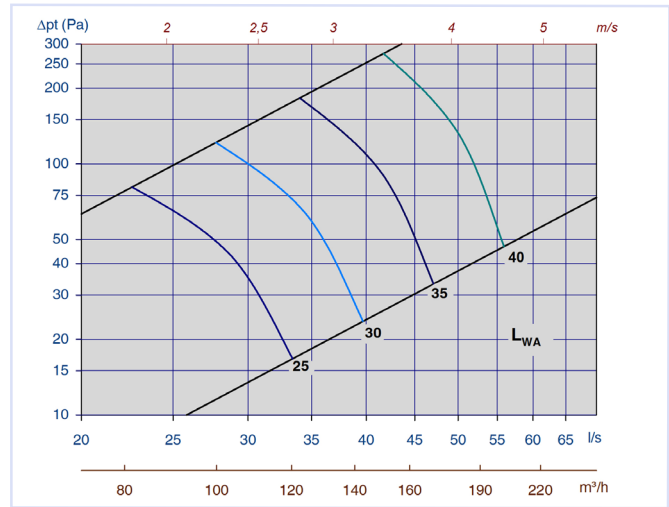

Diagram 12: TLG-G m/Luna 125-125 maks. spalt, tilluft

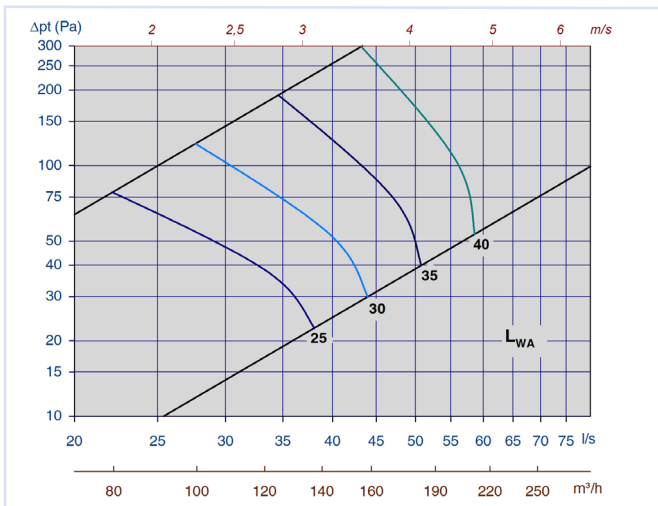

Diagram 13: TLG-G m/Luna 125-160 min. spalt, tilluft

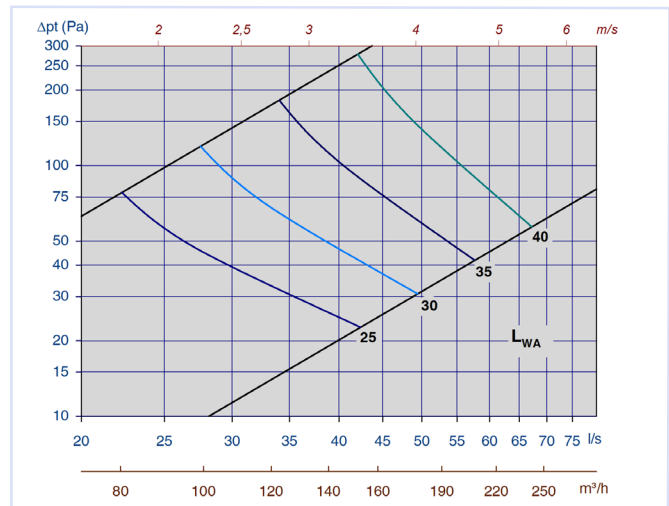

Diagram 14: TLG-G m/Luna 125-160 midt. spalt, tilluft

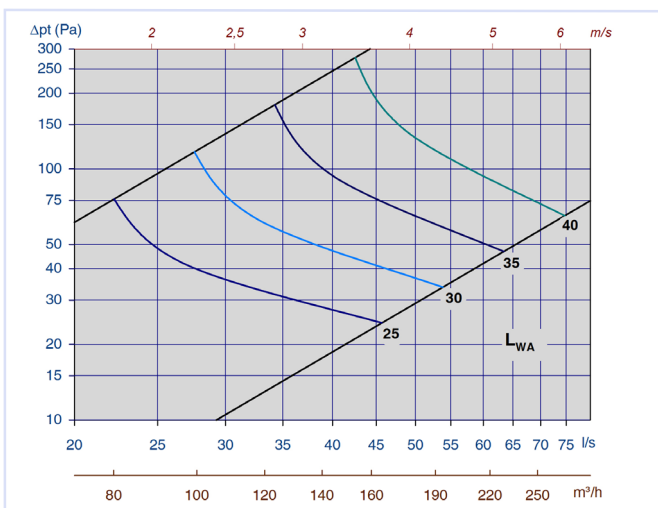

Diagram 15: TLG-G m/Luna 125-160 maks. spalt, tilluft

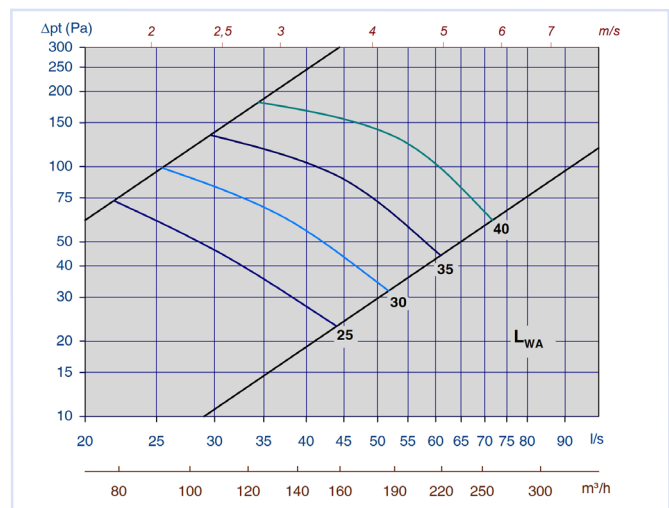

Diagram 16: TLG-G m/Luna 125-200 min. spalt, tilluft

TLG-G

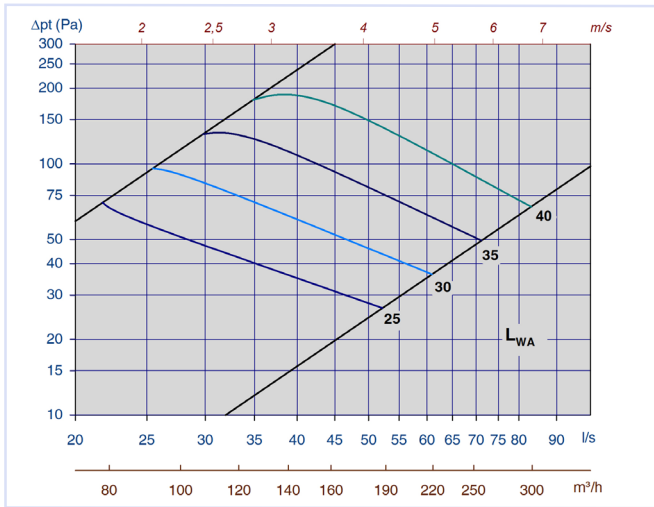

Diagram 17: TLG-G m/Luna 125-200 midt. spalt, tilluft

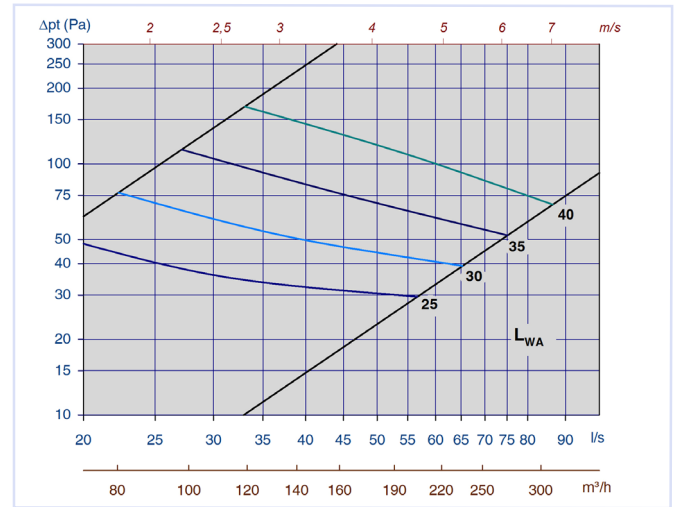

Diagram 18: TLG-G m/Luna 125-200 maks. spalt, tilluft

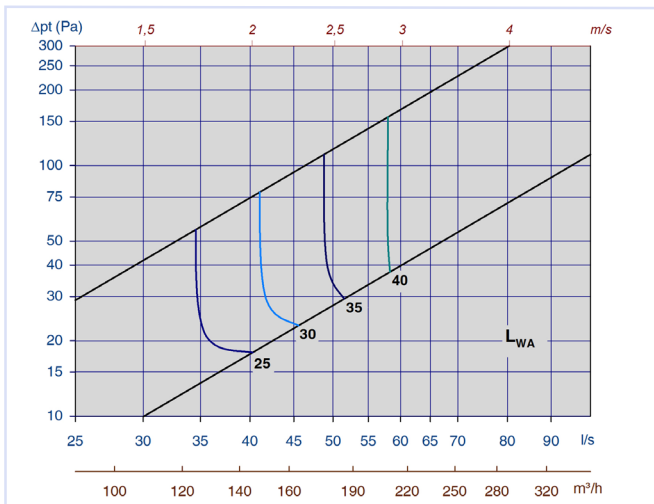

Diagram 19: TLG-G m/Luna 160-160 min. spalt, tilluft

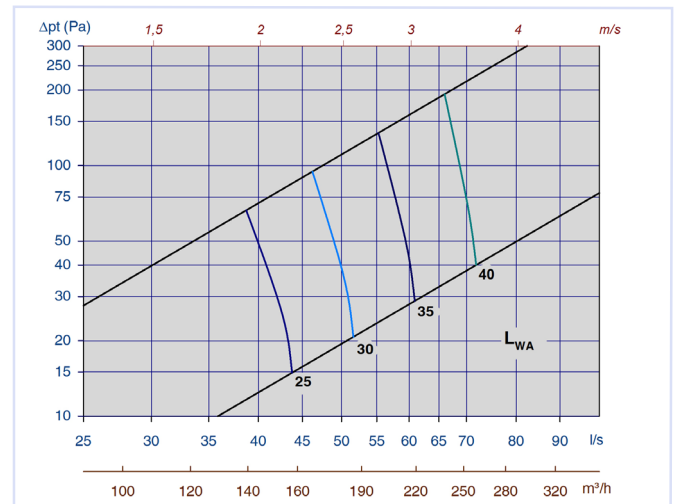

Diagram 20: TLG-G m/Luna 160-160 midt. spalt, tilluft

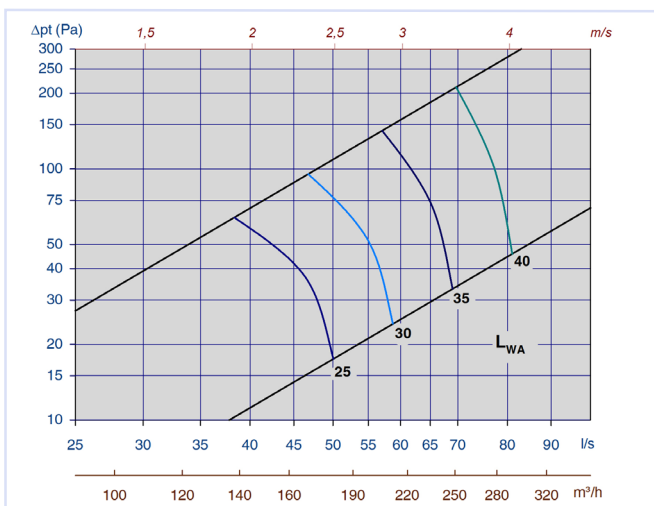

Diagram 21: TLG-G m/Luna 160-160 maks. spalt, tilluft

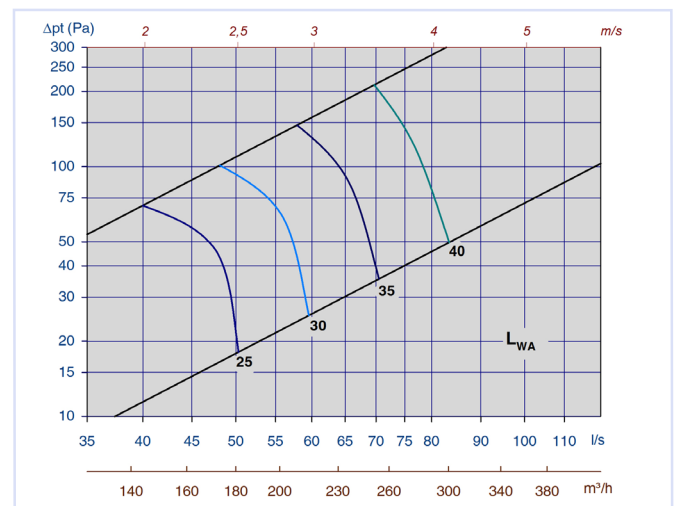

Diagram 22: TLG-G m/Luna 160-200 min. spalt, tilluft

TLG-G

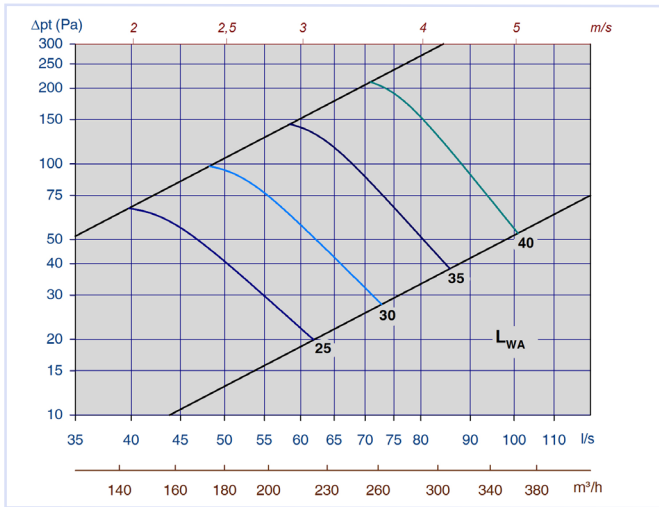

Diagram 23: TLG-G m/Luna 160-200 midt. spalt, tilluft

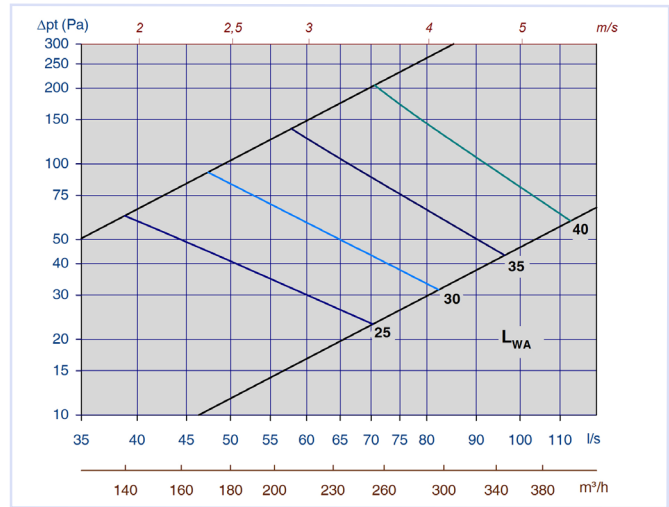

Diagram 24: TLG-G m/Luna 160-200 maks. spalt, tilluft

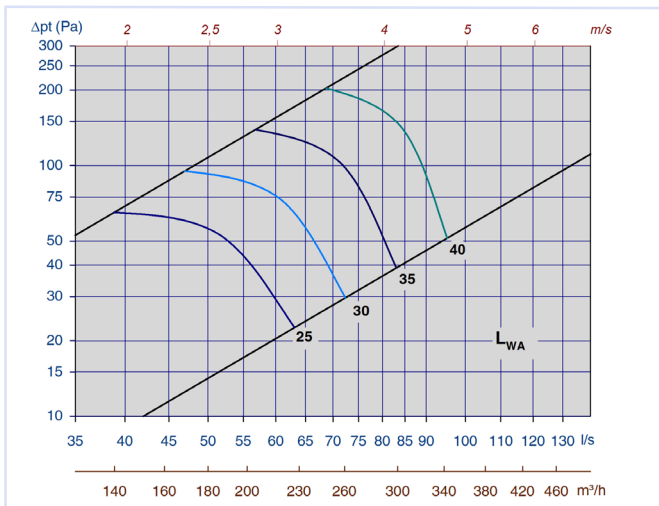

Diagram 25: TLG-G m/Luna 160-250 min. spalt, tilluft

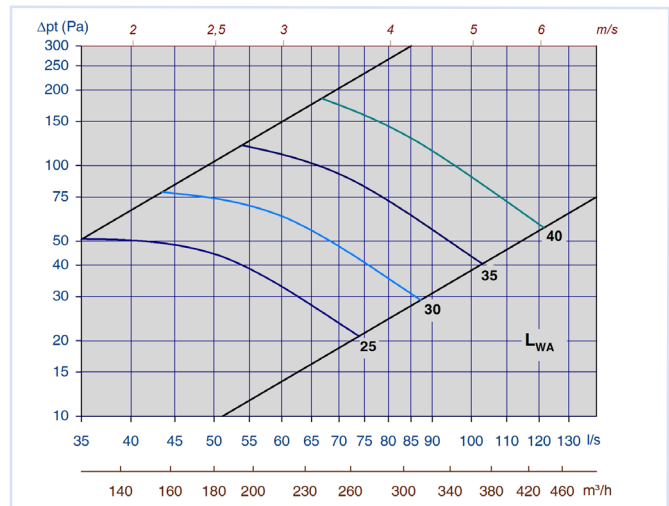

Diagram 26: TLG-G m/Luna 160-250 midt. spalt, tilluft

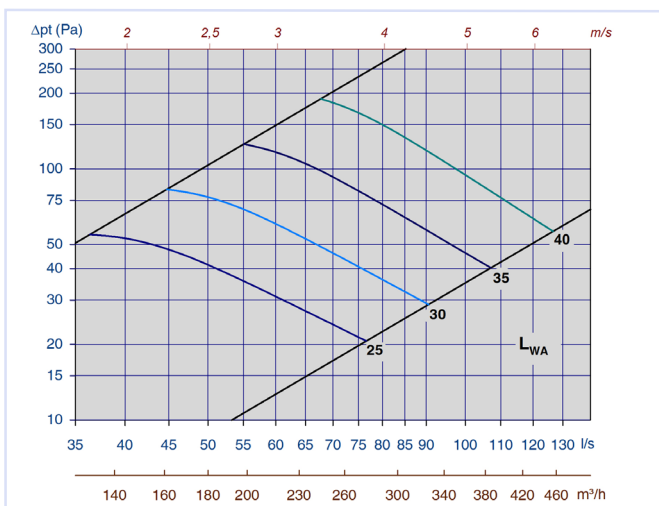

Diagram 27: TLG-G m/Luna 160-250 maks. spalt, tilluft

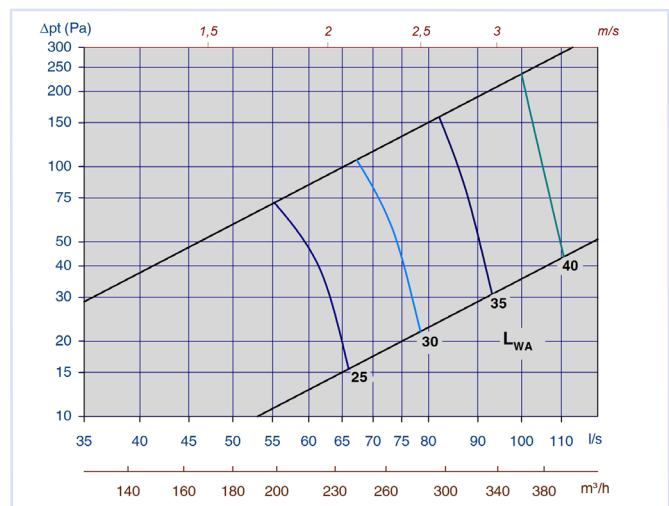

Diagram 28: TLG-G m/Luna 200-200 min. spalt, tilluft

TLG-G

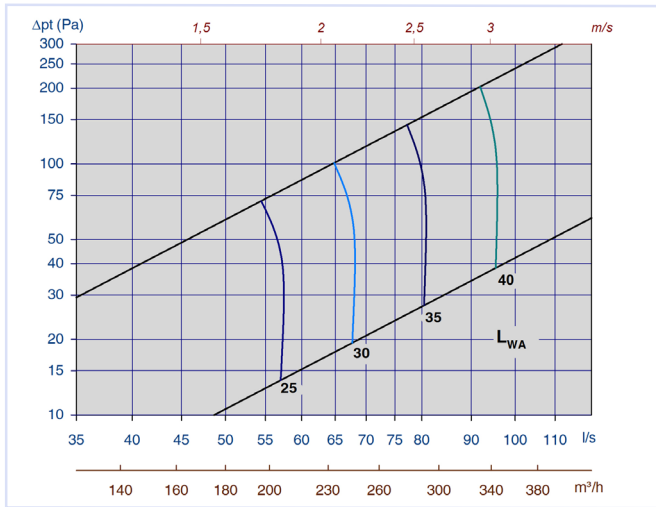

Diagram 29: TLG-G m/Luna 200-200 midt. spalt, tilluft

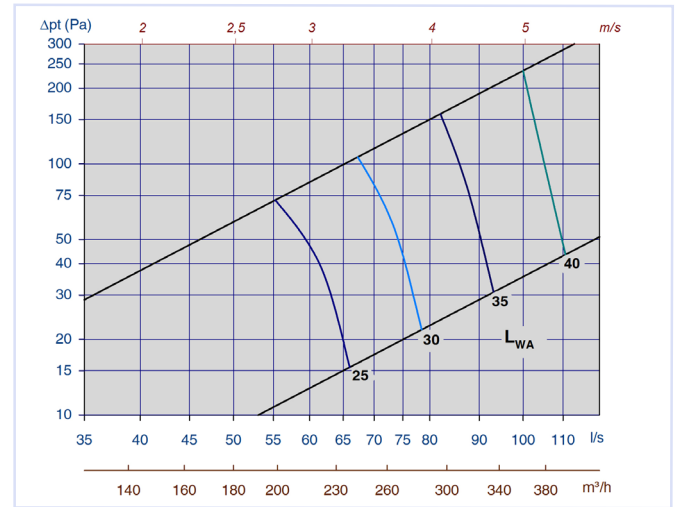

Diagram 30: TLG-G m/Luna 200-200 maks. spalt, tilluft

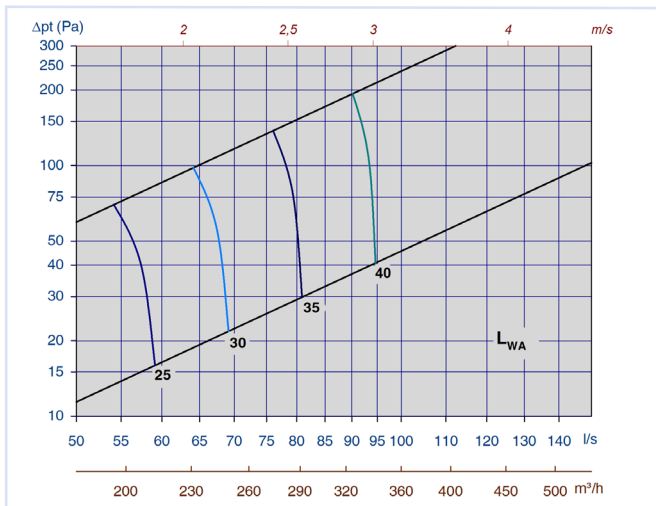

Diagram 31: TLG-G m/Luna 200-250 min. spalt, tilluft

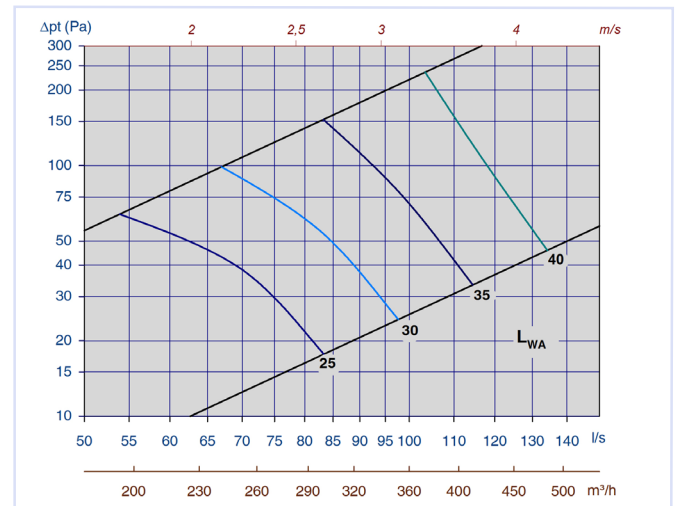

Diagram 32: TLG-G m/Luna 200-250 midt. spalt, tilluft

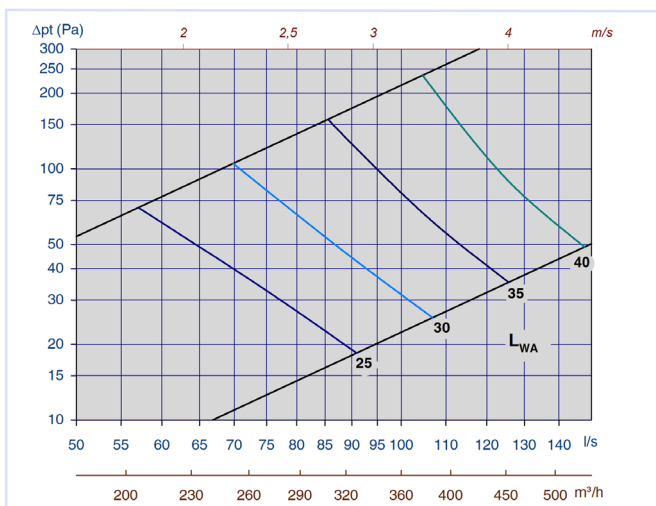

Diagram 33: TLG-G m/Luna 200-250 maks. spalt, tilluft

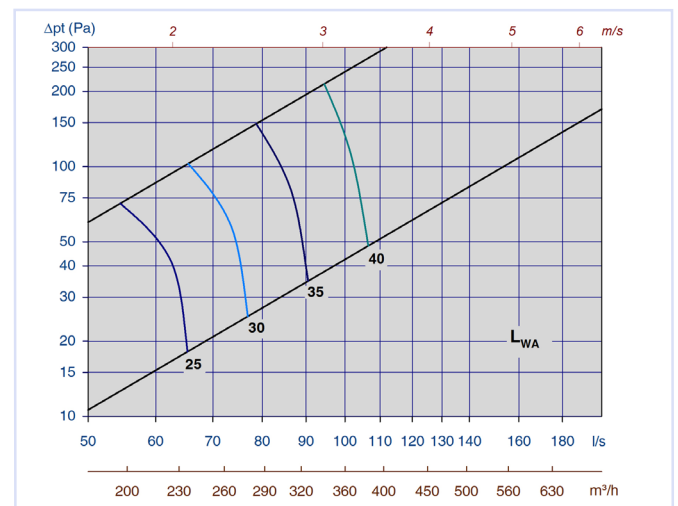

Diagram 34: TLG-G m/Luna 200-315 min. spalt, tilluft

TLG-G

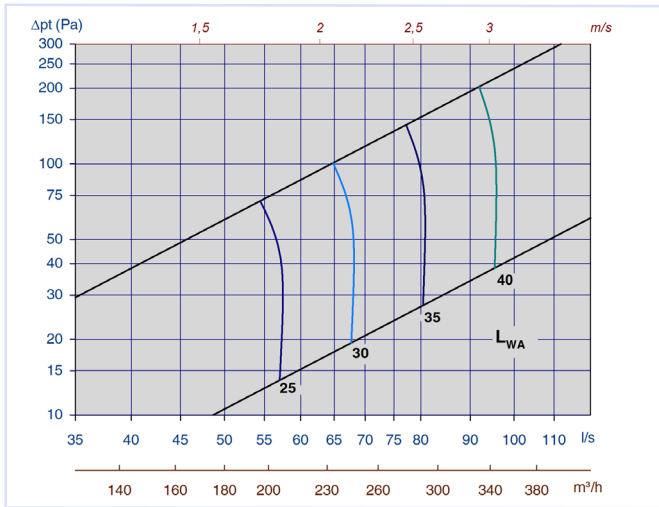

Diagram 35: TLG-G m/Luna 200-315 midt. spalt, tilluft

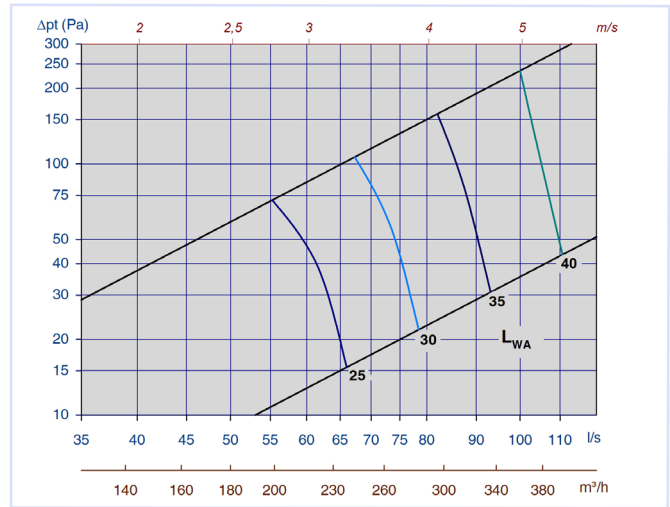

Diagram 36: TLG-G m/Luna 200-315 maks. spalt, tilluft

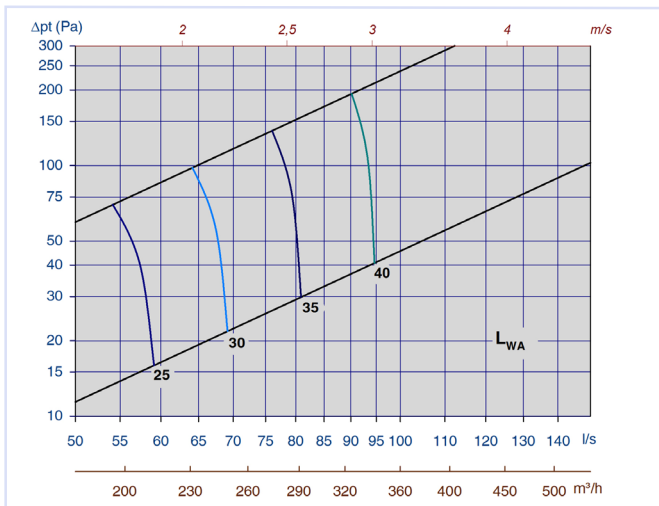

Diagram 37: TLG-G m/Luna 250-250 min. spalt, tilluft

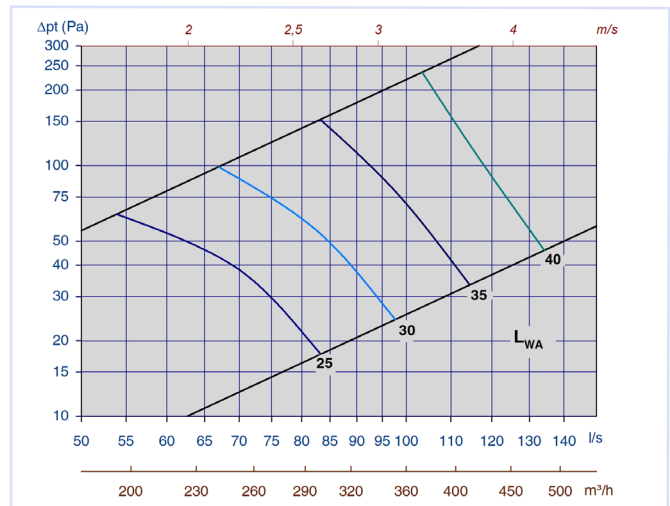

Diagram 38: TLG-G m/Luna 250-250 midt. spalt, tilluft

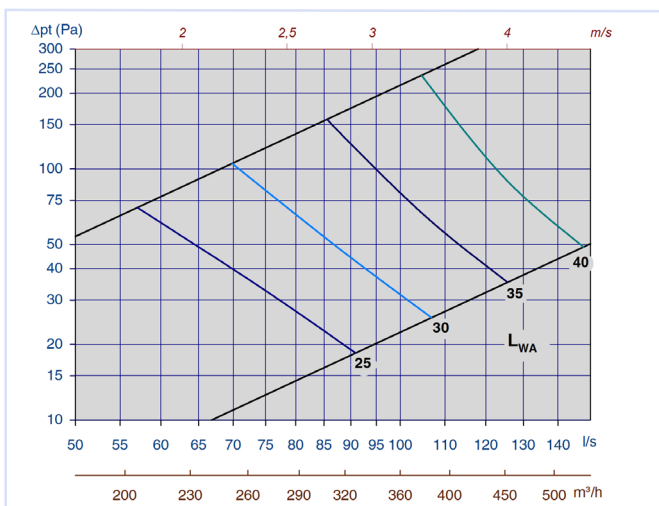

Diagram 39: TLG-G m/Luna 250-250 maks. spalt, tilluft

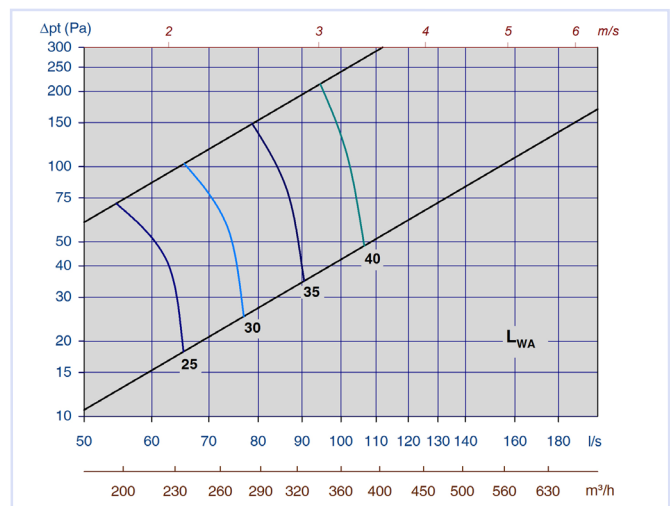

Diagram 40: TLG-G m/Luna 250-315 min. spalt, tilluft

TLG-G

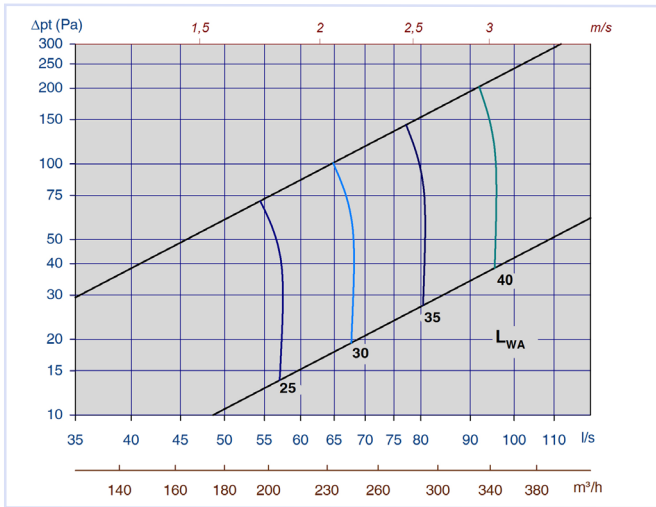

Diagram 41: TLG-G m/Luna 250-315 midt. spalt, tilluft

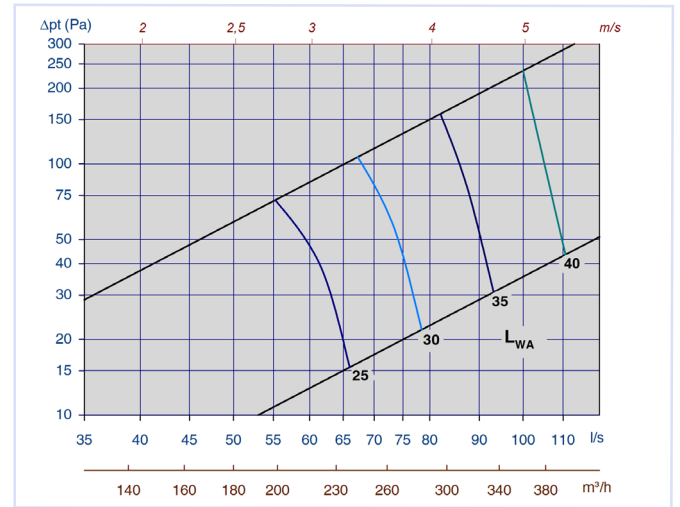

Diagram 42: TLG-G m/Luna 250-315 maks. spalt, tilluft

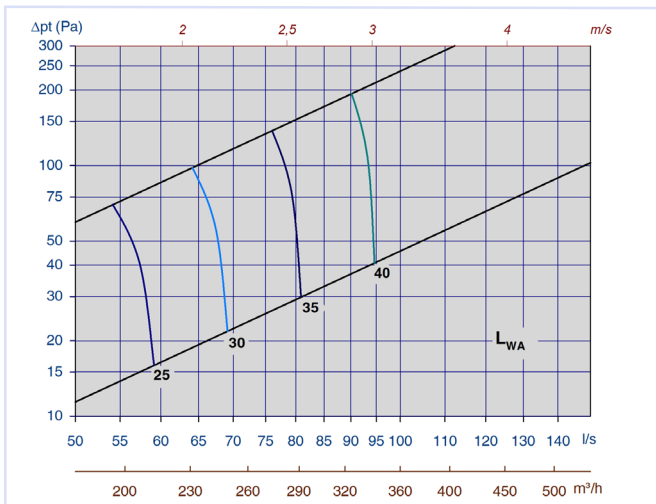

Diagram 43: TLG-G m/Luna 315-315 min. spalt, tilluft

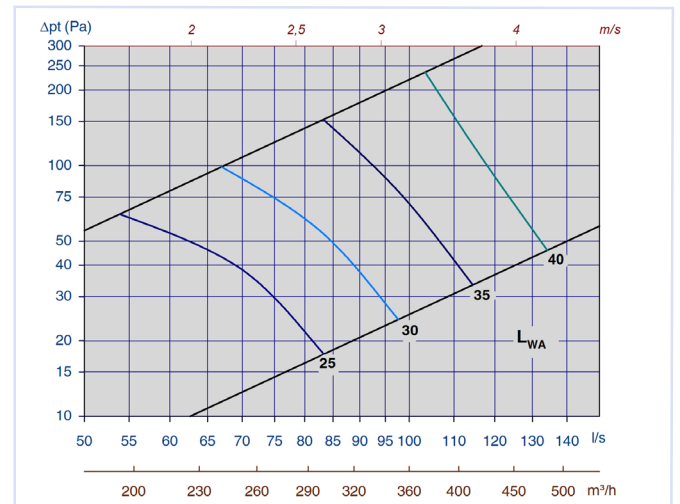

Diagram 44: TLG-G m/Luna 315-315 midt. spalt, tilluft

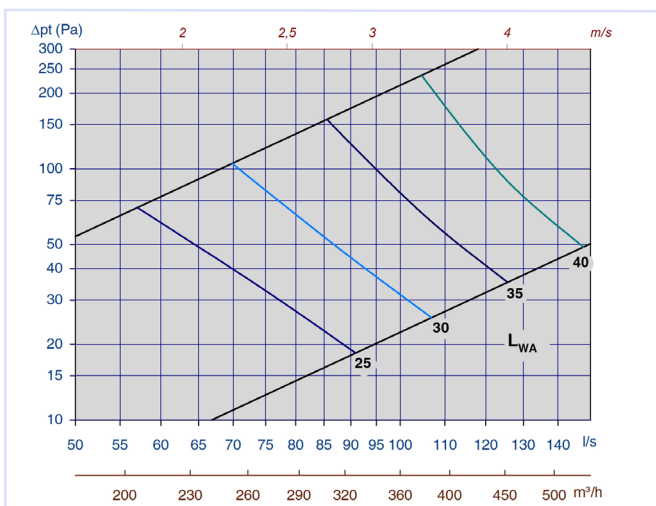

Diagram 45: TLG-G m/Luna 315-315 maks. spalt, tilluft

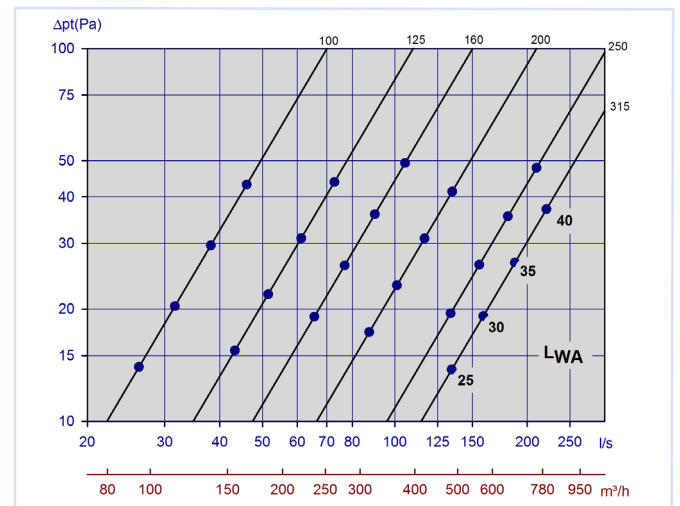

Diagram 46: TLG-G i kanal ende, tilluft

TLG-G

DIMENSJONERINGSDIAGRAM, AVTREKK

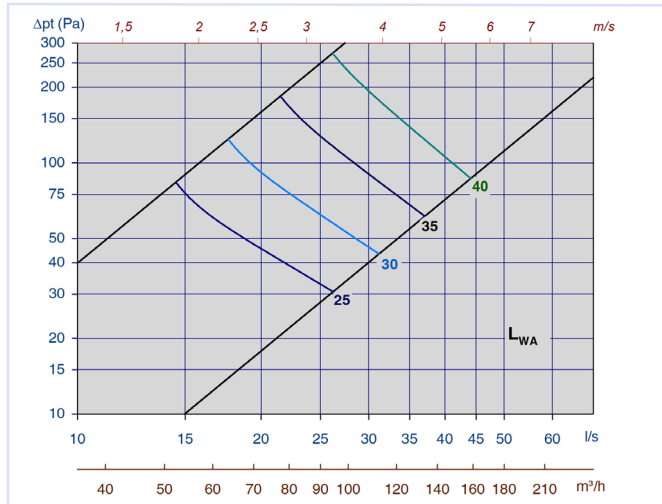

Diagram 47, TLG-G m/Luna 100-125 min spalt, avtrekk

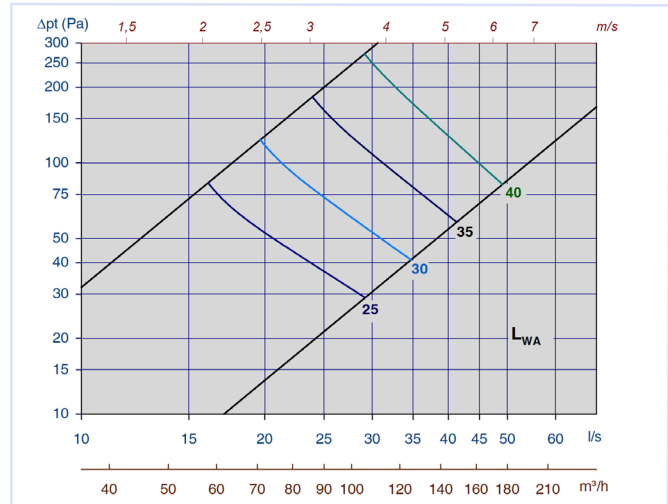

Diagram 48, TLG-G m/Luna 100-125, midt spalt, avtrekk

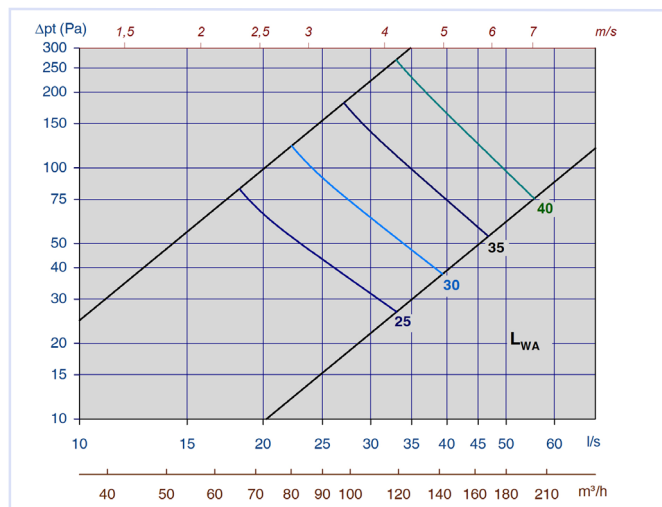

Diagram 49, TLG-G m/Luna 100-125, maks spalt, avtrekk

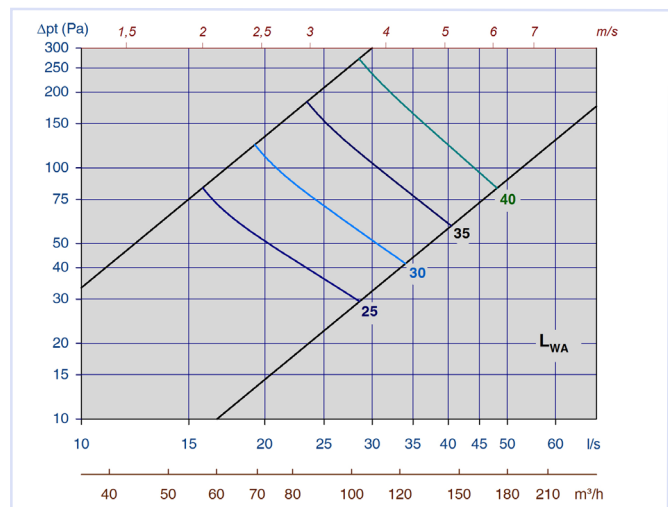

Diagram 50, TLG-G m/Luna 100-160, min spalt, avtrekk

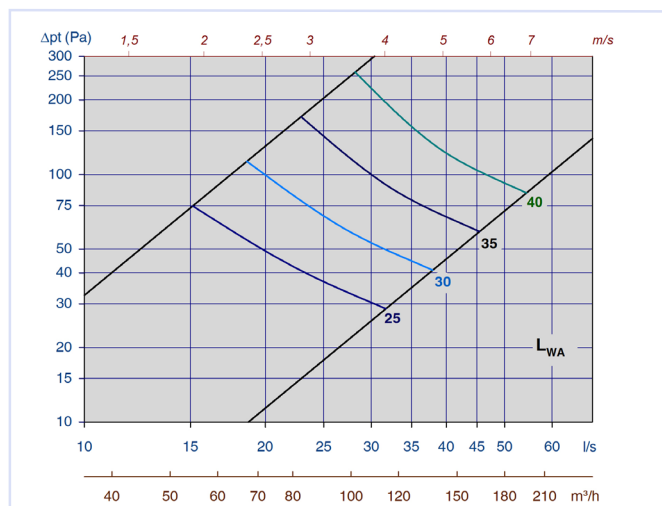

Diagram 51, TLG-G m/Luna 100-160, midt spalt, avtrekk

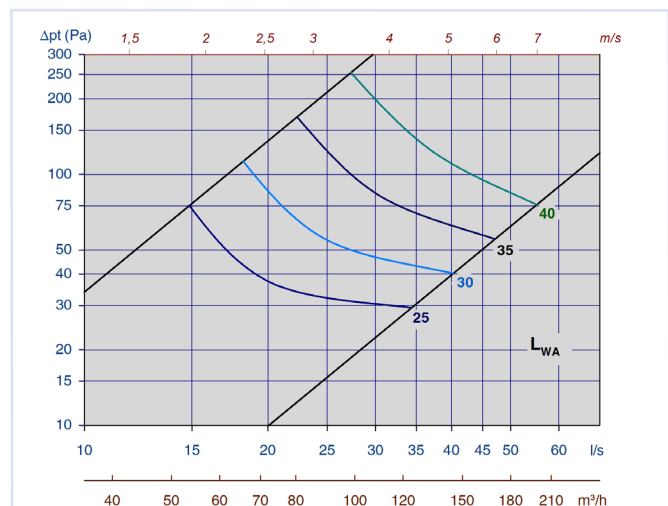

Diagram 52, TLG-G m/Luna 100-160, maks spalt, avtrekk

TLG-G

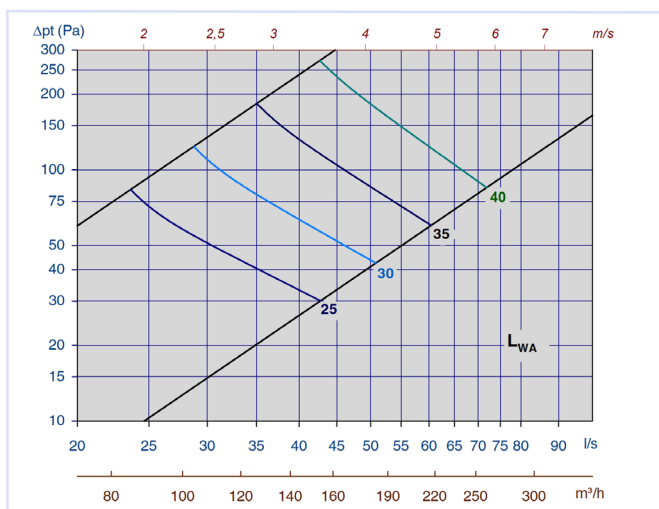

Diagram 53, TLG-G m/Luna 125-160, min spalt, avtrekk

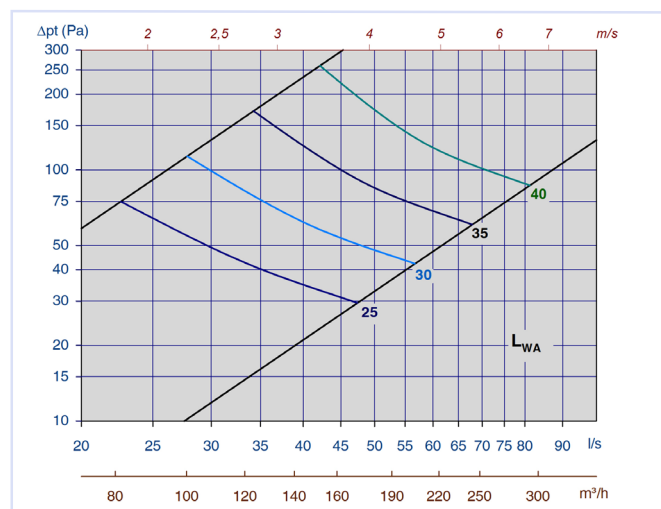

Diagram 54, TLG-G m/Luna 125-160, midt spalt, avtrekk

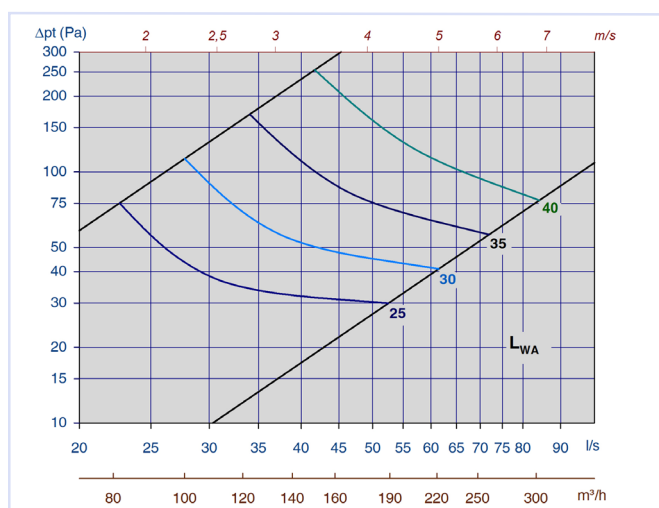

Diagram 55, TLG-G m/Luna 125-160, maks spalt, avtrekk

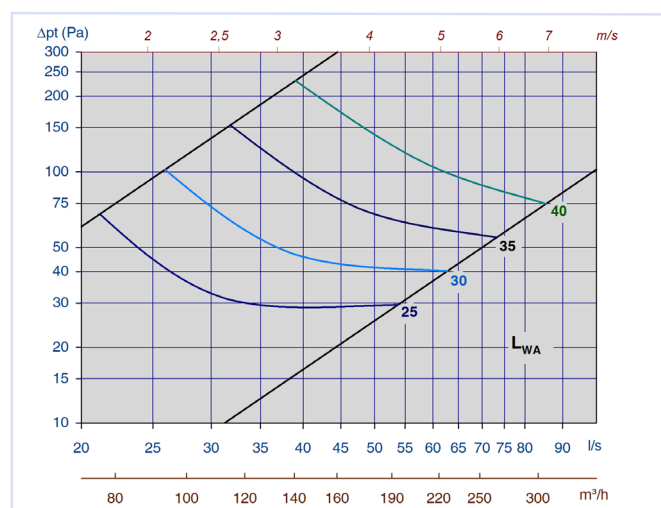

Diagram 56, TLG-G m/Luna 125-200, min spalt, avtrekk

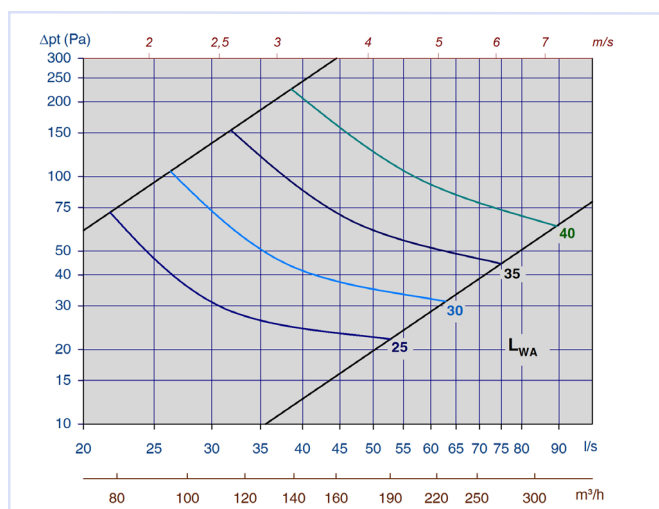

Diagram 57, TLG-G m/Luna 125-200, midt spalt, avtrekk

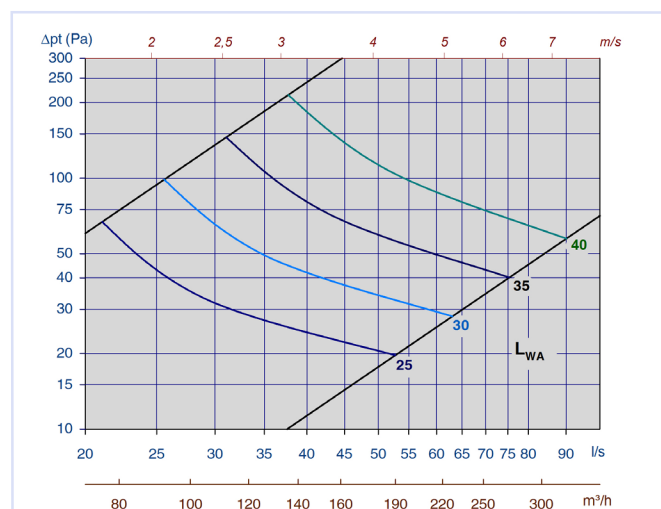

Diagram 58, TLG-G m/Luna 125-200, maks spalt, avtrekk

TLG-G

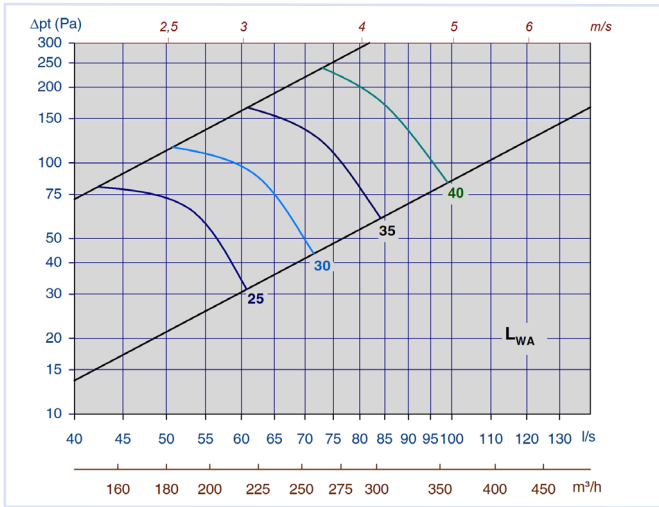

Diagram 59, TLG-G m/Luna 160-200, min spalt, avtrekk

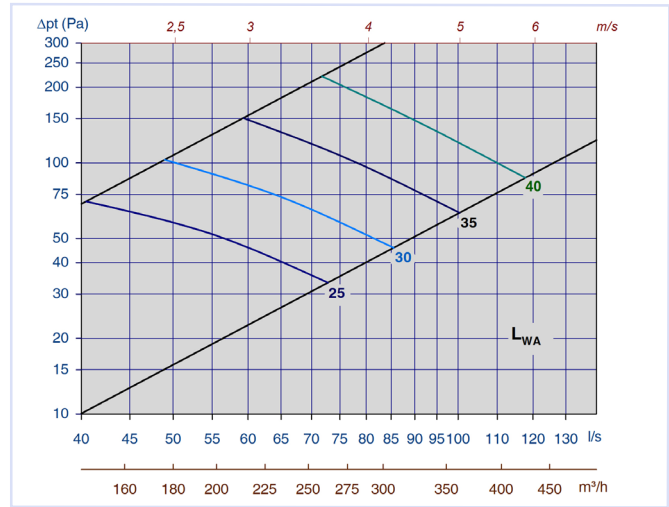

Diagram 60, TLG-G m/Luna 160-200, midt spalt, avtrekk

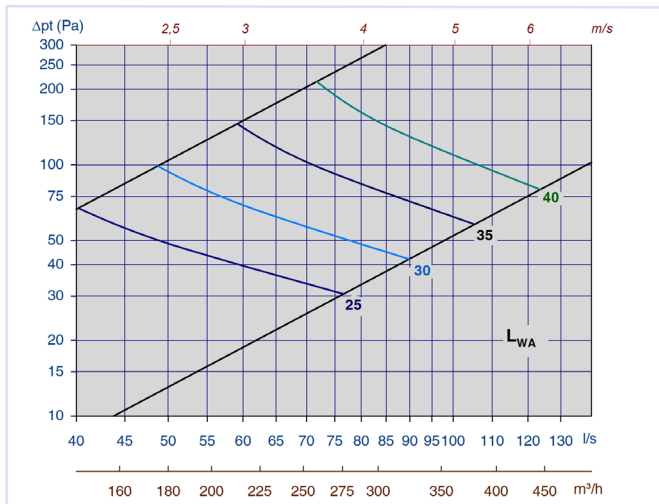

Diagram 61, TLG-G m/Luna 160-200, maks spalt, avtrekk

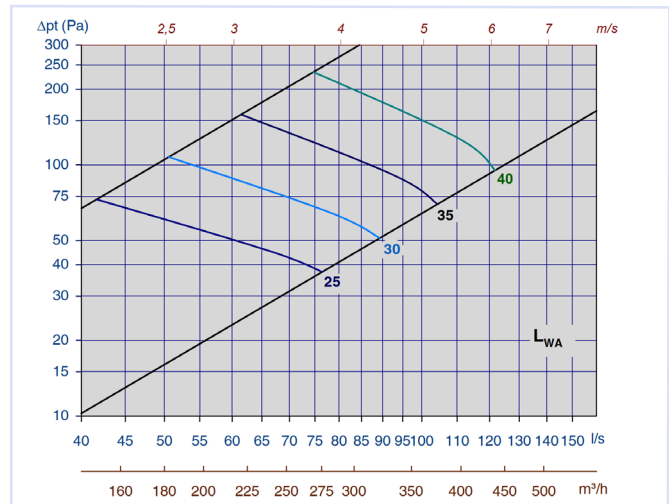

Diagram 62, TLG-G m/Luna 160-250, min spalt, avtrekk

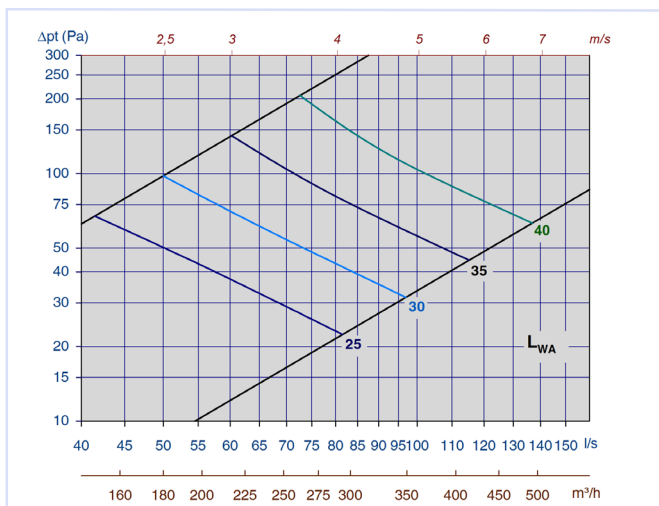

Diagram 63, TLG-G m/Luna 160-250, midt spalt, avtrekk

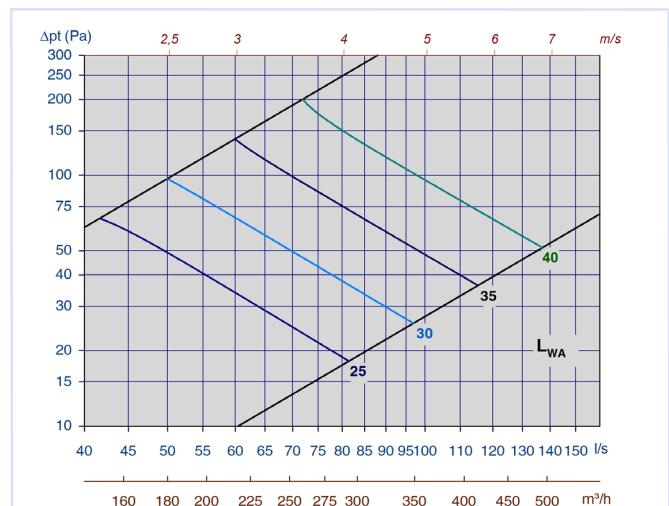

Diagram 64, TLG-G m/Luna 160-250, maks spalt, avtrekk

TLG-G

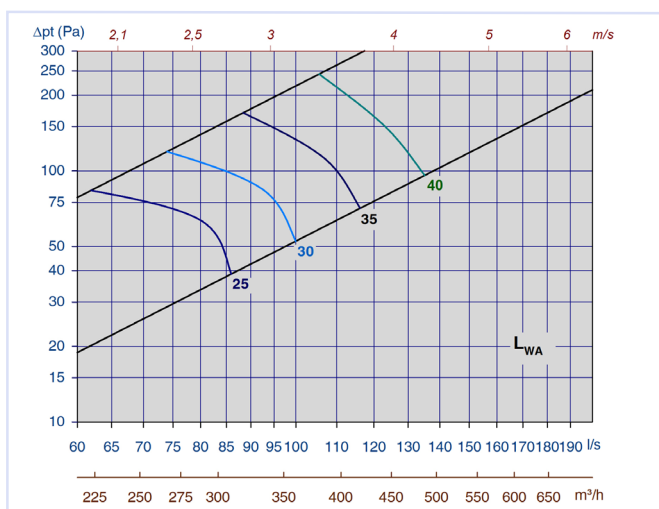

Diagram 65, TLG-G m/Luna 200-250, min spalt, avtrekk

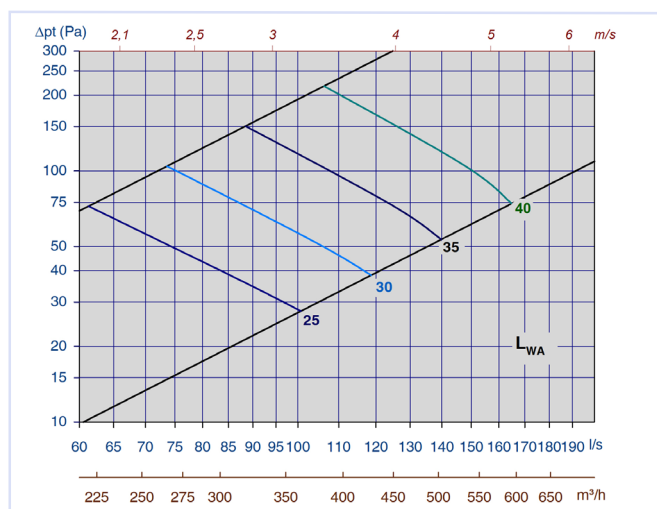

Diagram 66, TLG-G m/Luna 200-250, midt spalt, avtrekk

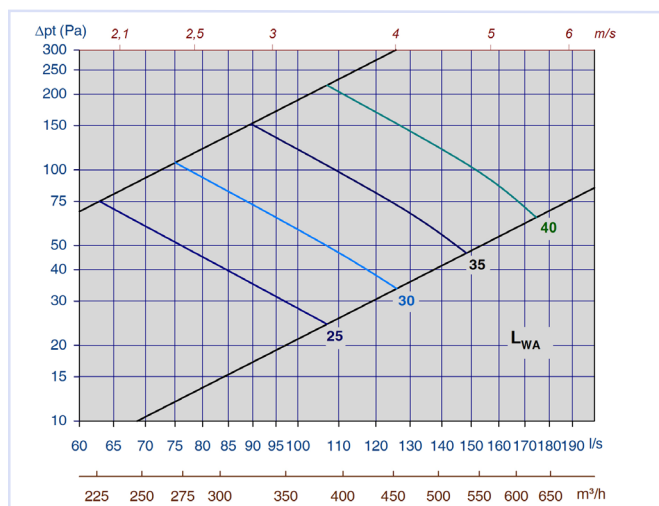

Diagram 67, TLG-G m/Luna 200-250, maks spalt, avtrekk

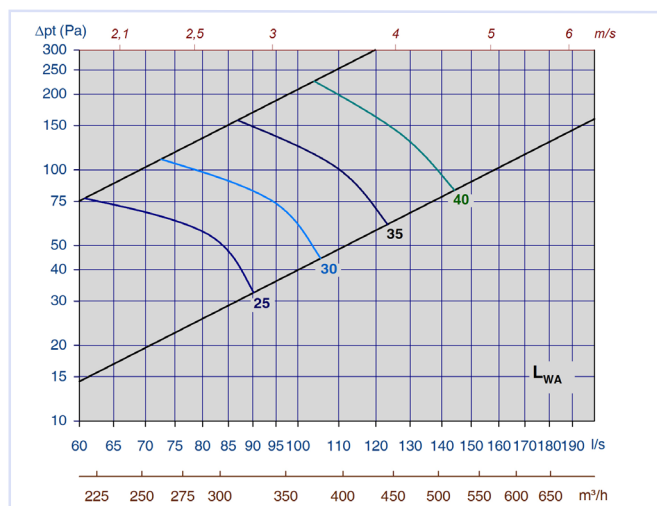

Diagram 68, TLG-G m/Luna 200-315, min spalt, avtrekk

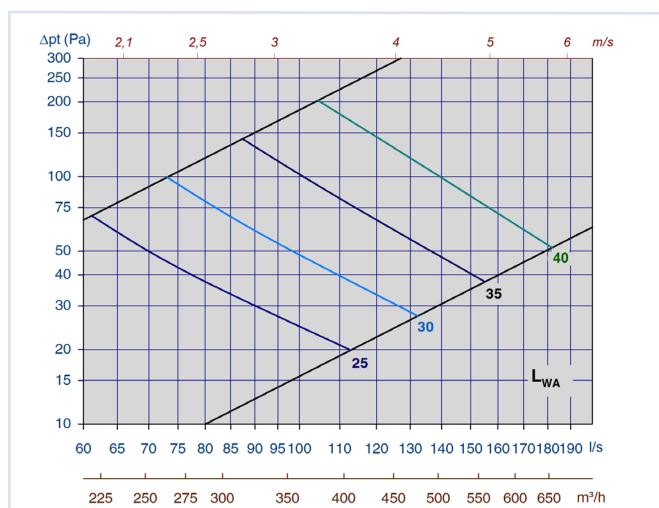

Diagram 69, TLG-G m/Luna 200-315, midt spalt, avtrekk

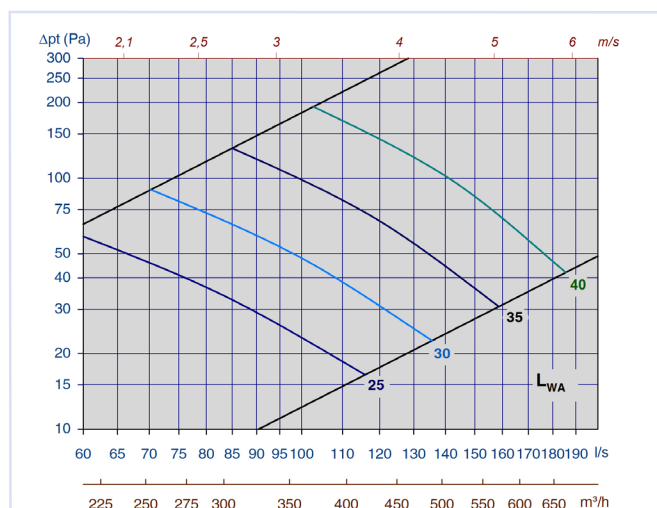

Diagram 70, TLG-G m/Luna 200-315, maks spalt, avtrekk

TLG-G

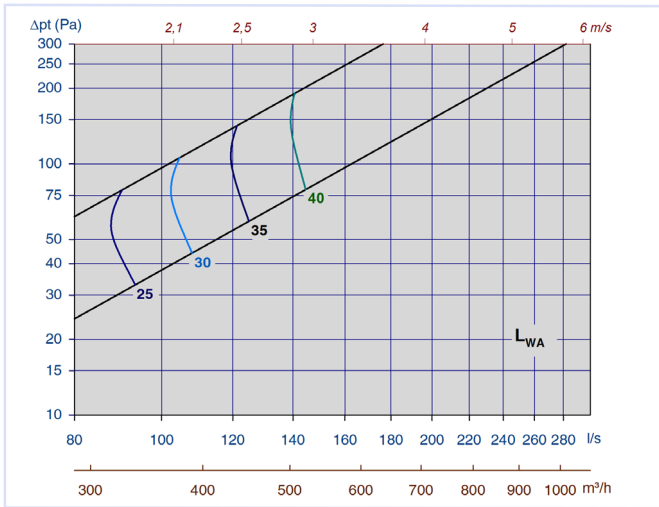

Diagram 71, TLG-G m/Luna 250-315, min spalt, avtrekk

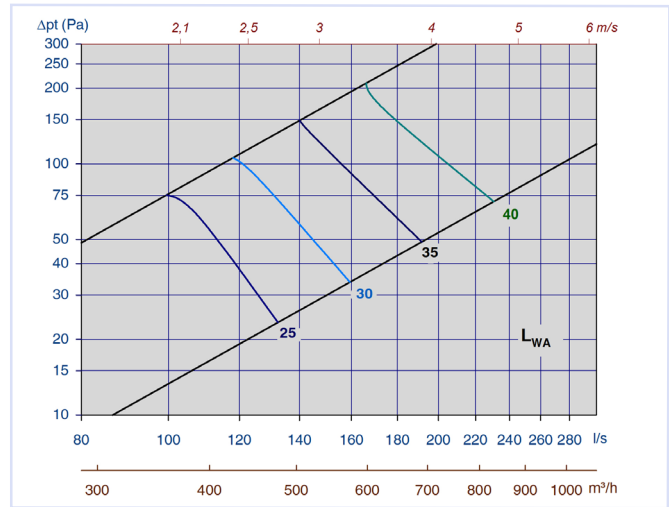

Diagram 72, TLG-G m/Luna 250-315, midt spalt, avtrekk

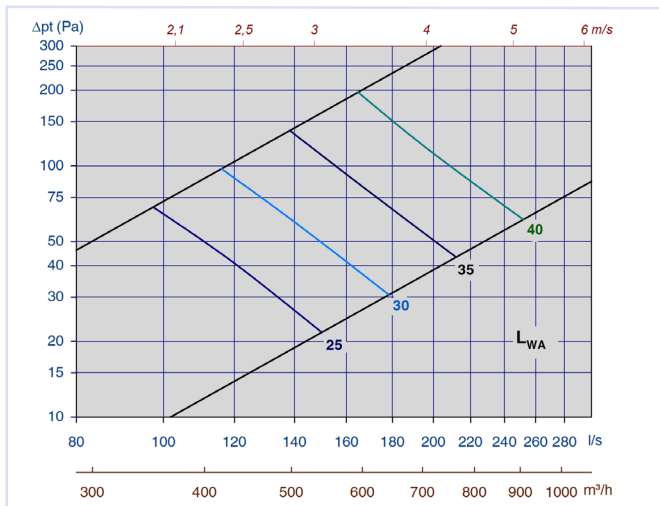

Diagram 73, TLG-G m/Luna 250-315, maks spalt, avtrekk

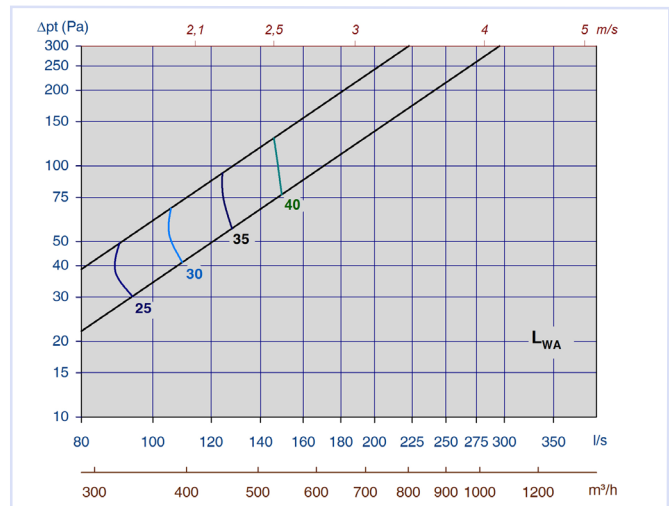

Diagram 74, TLG-G m/Luna 315-315, min spalt, avtrekk

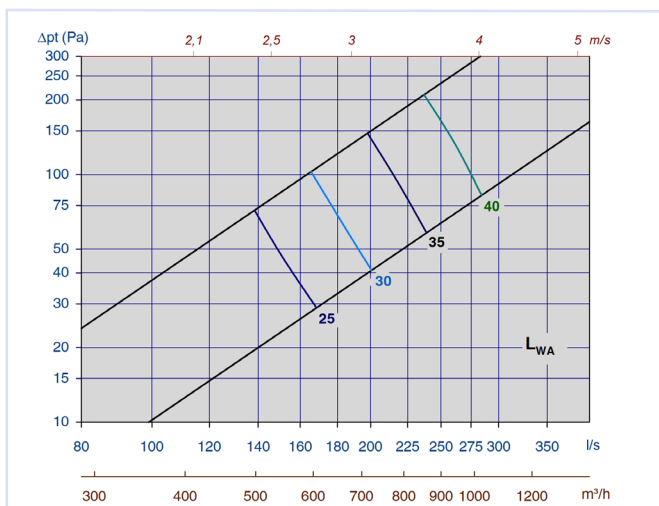

Diagram 75, TLG-G m/Luna 315-315, midt spalt, avtrekk

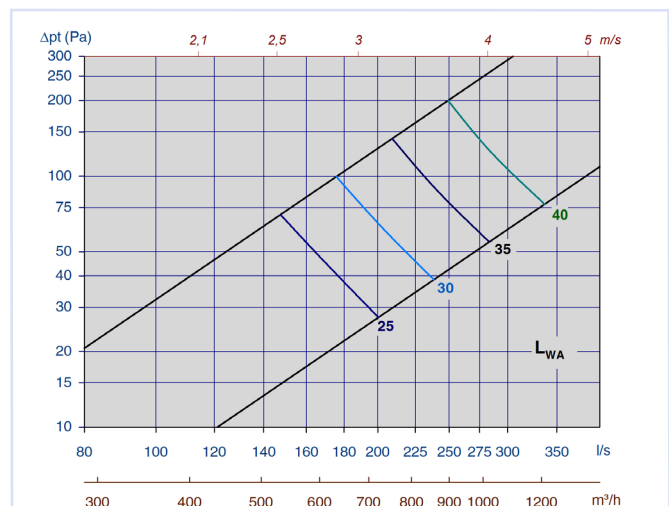

Diagram 76, TLG-G m/Luna 315-315, maks spalt, avtrekk

TLG-G

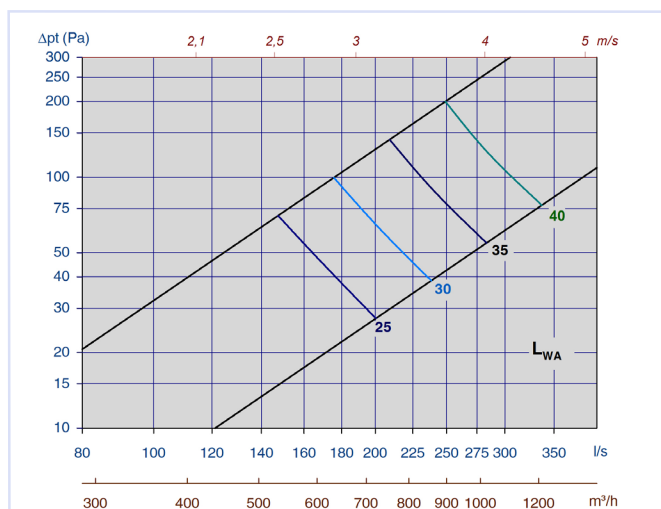

Diagram 77, TLG-G i kanal, avtrekk

Statisk lydemping inkl. enderefleksjon, TLG-G med Luna

TLG-G Dim.	Luna Dim.	Demping [dB]							
		63	125	250	500	1k	2k	4k	8k
100	100-100	25	16	17	20	22	20	16	12
125	100-125	26	12	14	18	20	19	14	17
160	100-160	25	11	13	16	18	19	14	17
125	125-125	24	16	16	20	22	17	13	19
160	125-160	24	11	10	16	19	15	11	17
200	125-200	25	11	9	15	18	15	10	15
160	160-160	20	13	15	16	12	10	11	10
200	160-200	17	9	10	16	18	11	13	17
250	160-250	19	11	12	15	17	10	11	11
200	200-200	18	12	15	18	18	12	16	18
250	200-250	17	12	14	16	16	10	14	16
315	200-315	18	11	13	13	15	9	12	15
250	250-250	15	10	14	15	15	11	13	16
315	250-315	17	11	13	15	14	10	12	14
315	315-315	12	9	14	16	11	11	12	14

Tabell 7

Korreksjonsfaktor [KO], TLG-G med Luna, tilluft

TLG-G Dim.	Luna Dim.	KO-faktor [dB]							
		63	125	250	500	1k	2k	4k	8k
100	100-100	-11	-5	1	-4	-5	-10	-11	-13
125	100-125	-12	-6	0	-4	-6	-9	-8	-11
160	100-160	-13	-8	-1	-6	-5	-8	-9	-14
125	125-125	-9	-6	0	-5	-3	-9	-11	-16
160	125-160	-10	-9	-3	-8	-5	-7	-8	-17
200	125-200	-8	-5	-3	-7	-6	-8	-7	-12
160	160-160	-10	-9	1	-5	-4	-9	-12	-17
200	160-200	-13	-2	1	-5	-7	-8	-8	-11
250	160-250	-14	-8	-3	-6	-6	-7	-9	-13
200	200-200	-14	-8	1	-4	-5	-9	-13	-15
250	200-250	-14	-9	0	-4	-5	-8	-11	-16
315	200-315	-14	-9	-6	-8	-5	-7	-8	-10
250	250-250	-13	-8	-1	-3	-4	-9	-12	-15
315	250-315	-13	-8	0	-4	-4	-9	-12	-13
315	315-315	-11	-6	1	-2	-5	-10	-13	-13

Tabell 8, for beregning av frekvensfordelt støy brukes avlest lydeffektnivå, LWA i diagram, og formel: LW = LWA + KO

TLG-G

Statisk lydemping inkl. enderefleksjon for TLG-G i kanal

TLG-G	Demping [dB]							
Dim.	63	125	250	500	1k	2k	4k	8k
100	25	17	13	6	3	3	3	5
125	22	16	12	5	2	1	3	4
160	20	15	11	5	1	1	2	4
200	15	12	10	2	1	1	1	3
250	15	9	7	1	1	1	1	1
315	14	8	5	1	1	1	1	1

Tabell 9

Korreksjonsfaktor [KO], TLG-G i kanal, tilluft

TLG-G	KO [dB]							
Dim.	63	125	250	500	1k	2k	4k	8k
100	-12	-6	1	-1	-6	-12	-14	-13
125	-11	-5	0	-2	-6	-9	-13	-12
160	-13	-8	1	-3	-5	-8	-12	-15
200	-14	-8	0	-2	-5	-9	-14	-15
250	-14	-9	3	-3	-6	-10	-12	-16
315	-15	-9	1	-3	-5	-10	-14	-16

Tabell 10, For beregning av frekvensfordelt støy brukes avlest lyd-effektnivå, L_{WA} i diagram, og formel: $L_W = L_{WA} + KO$

Korreksjonsfaktor [KO], TLG-G med Luna, avtrekk

TLG-G	KO-faktor (dB)							
Dim.	63	125	250	500	1K	2K	4K	8K
100-125	-15	-10	-2	-7	-6	-8	-6	-11
100-160	-13	-7	3	-6	-7	-9	-8	-13
125-160	-13	-8	0	-7	-7	-5	-11	-15
125-200	-13	-7	-2	-8	-8	-10	-5	-7
160-200	-15	-9	0	-6	-10	-7	-6	-12
160-250	-15	-10	0	-4	-11	-7	-6	-11
200-250	-13	-7	-1	-6	-6	-6	-9	-13
200-315	-13	-7	-1	-5	-7	-7	-8	-11
250-315	-14	-8	-2	-6	-6	-6	-8	-12
315-315	-14	-8	-3	-5	-4	-7	-11	-15

Tabell 11, For beregning av frekvensfordelt støy brukes avlest lydeffekt-nivå, L_{WA} i diagram, og formel: $L_W = L_{WA} + KO$

Korreksjonsfaktor [KO], TLG-G i kanal, avtrekk

TLG-G	KO-faktor (dB)							
Dim.	63	125	250	500	1K	2K	4K	8K
Ø100	-16	-11	-9	-8	-7	-5	-7	-15
Ø125	-16	-10	-11	-11	-8	-5	-6	-17
Ø160	-14	-9	-6	-7	-6	-5	-9	-14
Ø200	-14	-9	-7	-7	-7	-6	-7	-15
Ø250	-13	-7	-4	-4	-5	-8	-9	-13
Ø315	-11	-9	-10	-10	-5	-6	-8	-15

Tabell 12, For beregning av frekvensfordelt støy brukes avlest lydeffekt-nivå, L_{WA} i diagram, og formel: $L_W = L_{WA} + KO$

SPREDNINGSMØNSTER, TLG-G

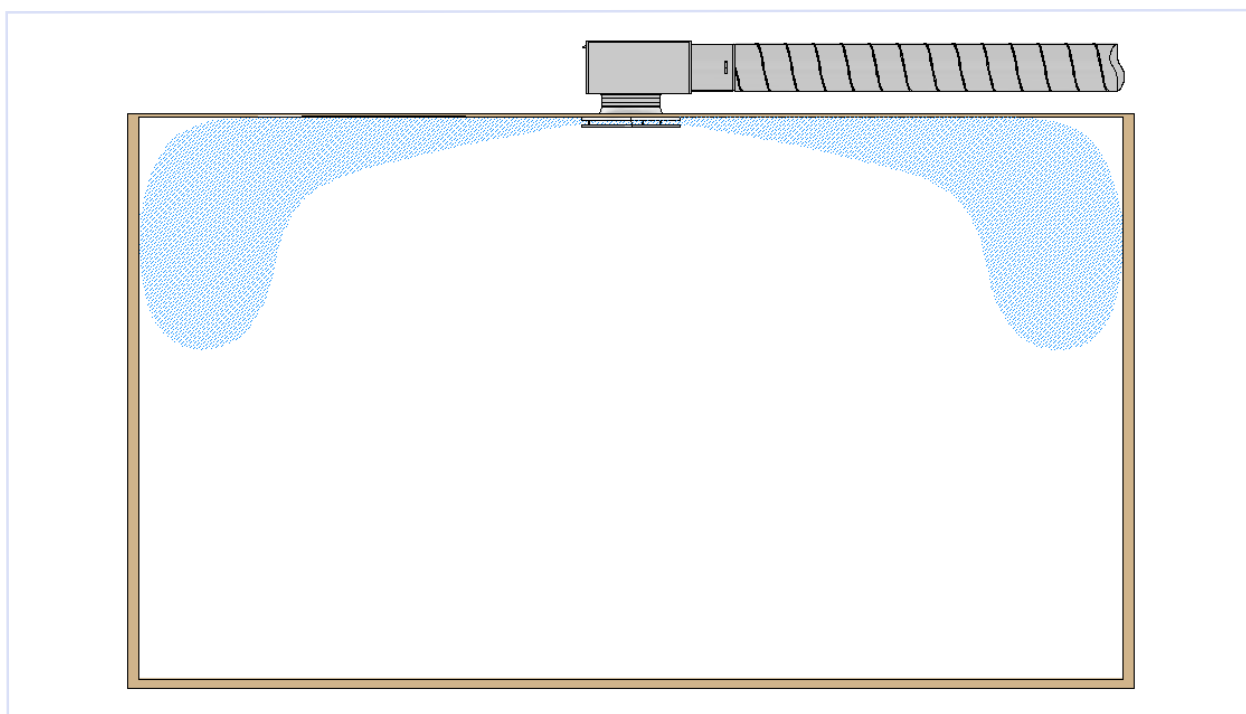

Figur 3

TLG-G

HASTIGHETSDIAGRAMMER

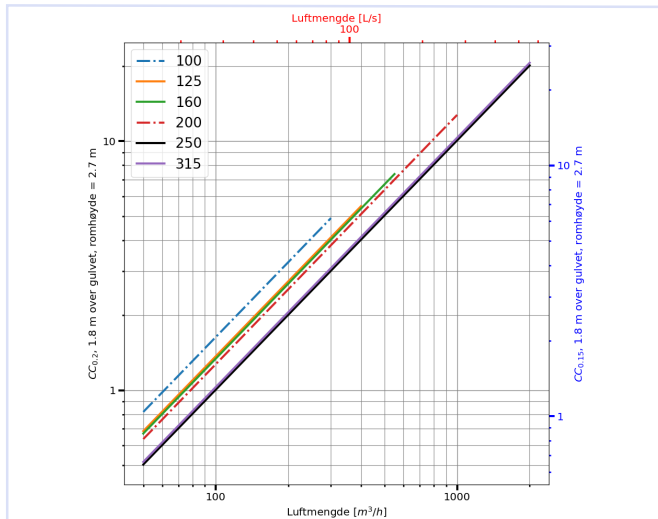

Diagram 78, anbefalt min. cc ved sluttastighet 0,2 og 0,15 m/s, 1,8m over gulv ved romhøyde 2,7m.

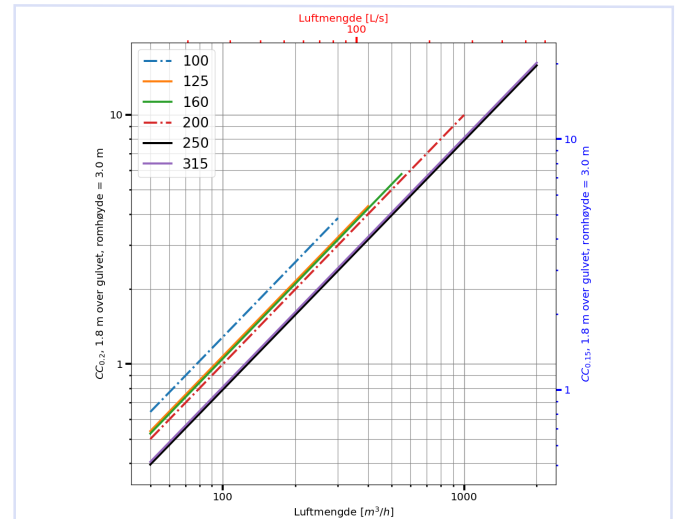

Diagram 79, anbefalt min. cc ved sluttastighet 0,2 og 0,15 m/s, 1,8m over gulv ved romhøyde 3m.

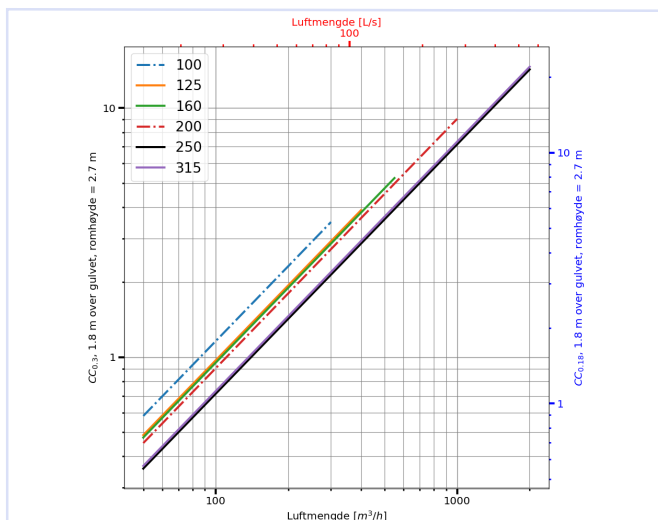

Diagram 80, anbefalt min. cc ved sluttastighet 0,3 og 0,18 m/s, 1,8m over gulv ved romhøyde 2,7m.

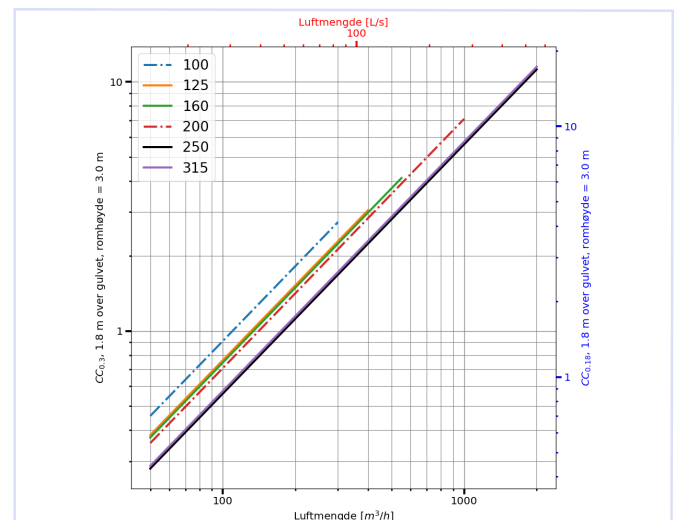

Diagram 81, anbefalt min. cc ved sluttastighet 0,3 og 0,18 m/s, 1,8m over gulv ved romhøyde 3m

KASTELENGDE, TLG-G

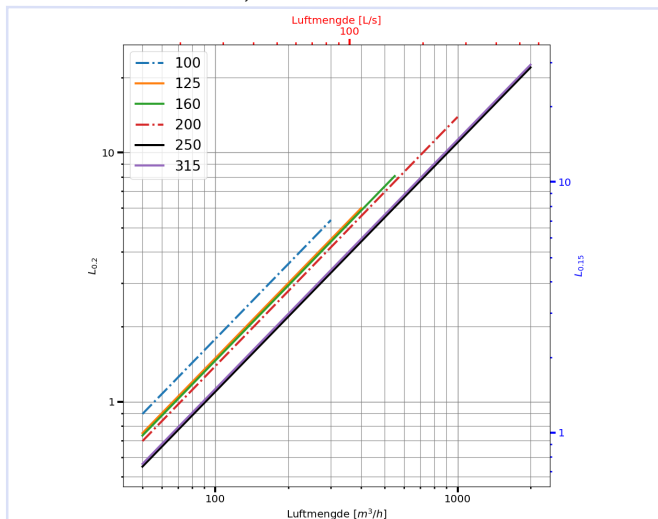

Diagram 82, kastelengde sluttastighet 0,2 og 0,15 m/s.

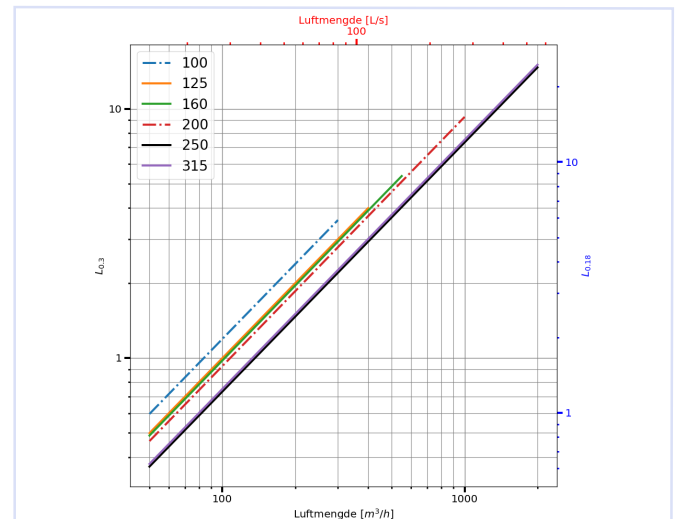
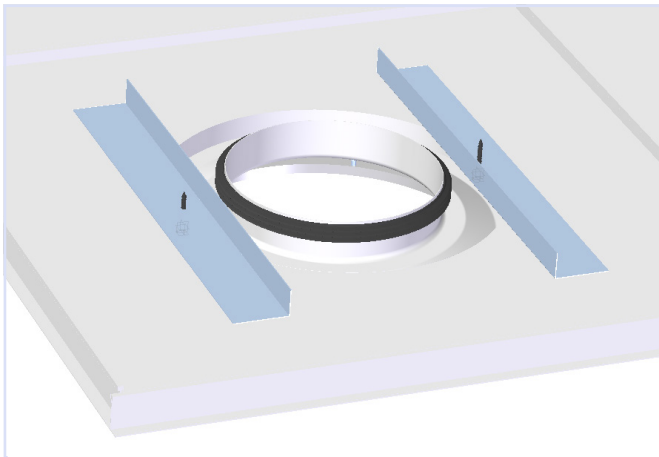

Diagram 83, kastelengde sluttastighet 0,3 og 0,18 m/s.

TLG-G

MONTERING

Ved montering i fast tak eller innfelt i himlingsplate festes TLG-G ved hjelp av to montasjevinkler som vist i figur 4, eller ventilen skrues fast i kammerts utløp. Dersom plenums-kammer Luna benyttes pendles dette i opphengsbraketten i bakkant med gjengestag eller bånd (figur 5).



Figur 4, montasje

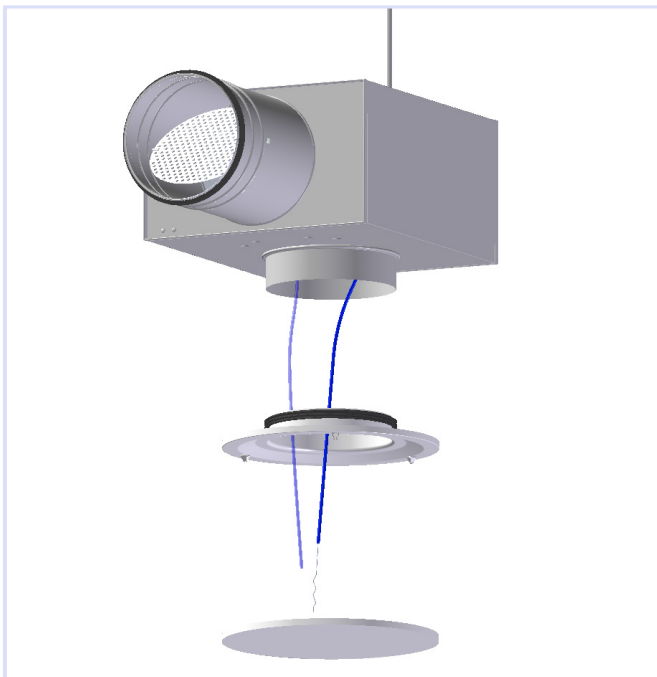

Figur 5, montasje

INNREGULERING

Ved innregulering må ventilfronten være påmontert. Måleslange og reguleringsvaier trekkes ut gjennom spalten på ventilen. Spjeldet låses med låsemutter på wiren, husk å skru låsemutteren skikkelig til slik at spjeldet ikke endrer stilling. K-faktorer for utregning av luftmengde finnes på merkelappen i ventilen, eller i vår innjusteringsguide på vår hjemmeside: www.trox.no.

VEDLIKEHOLD

Ventilen rengjøres med en fuktig klut. Ved rensing av kanalnettet fjernes ventilfronten for å komme til kanalen. Dersom Luna benyttes, demonteres fordelingsplaten og spjeldet for fri tilgang til kanalen.

MILJØ

Forespørsel vedrørende byggvaredeklarasjon kan rettes til en av våre selgere, eller finnes på vår hjemmeside: www.trox.no